



**WACKER  
NEUSON**

Ersatzteilkatalog  
Spare parts catalog  
Catálogo de piezas de repuesto  
Catalogue de pièces de rechange

Vibrationsplatte  
Vibratory plate  
Plancha vibratoria  
Plaque vibrante

**DPU45Yeh EU**



Type	DPU45Yeh EU
Material Number	5100068380
Version	101
Language	de   en   es   fr



[www.wackerneuson.com](http://www.wackerneuson.com)

Copyright © 11.2023  
Wacker Neuson Produktion GmbH & Co. KG  
Printed in Germany.  
All rights reserved.

Ein Typenschild mit Typ, Artikelnummer, Version und Maschinen-Nummer ist an jedem Gerät angebracht. Die Daten von diesem Schild bitte notieren, damit sie auch bei Verlust oder Beschädigung des Schildes noch vorhanden sind. Der Typ, die Artikelnummer, die Versions-Nummer und die Maschinen-Nummer sind bei der Ersatzteilbestellung oder Nachfragen bezüglich Service-Informationen stets erforderlich.

Bei den in den Ersatzteillisten fettgedruckten Nummern handelt es sich um empfohlene Ersatzteile. Dies bedeutet, daß diese Teile bei normalen Anwendungsbedingungen natürlicher Abnutzung ausgesetzt sind und gelegentlich ersetzt oder überarbeitet werden müssen. Es wird geraten, diese Teile auf Lager bereit zu haben, um für Service-Arbeiten an diesem Gerät vorbereitet zu sein. Lagerbestände für diese und andere Teile, welche für ausgiebigere Reparaturarbeiten benötigt werden, können je nach Service-Gewohnheiten der einzelnen Kunden variieren.

Die Nummern meines Gerätes sind:

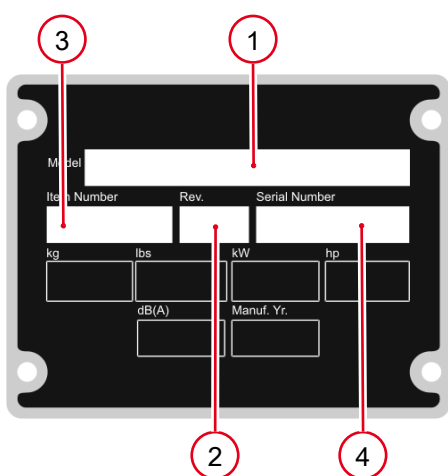

1. Typ
2. Version
3. Artikel-Nr.
4. Maschinen-Nr.

**Umrechnungstabelle**

Volumeneinheit	
1 ml	0.034 US fl.oz.
1 l	0.260 gal
Längeneinheit	
1 mm	0.039 in
1 m	3.280 ft
Gewicht	
1 kg	2.200 lbs
1 g	0.035 oz
Geschwindigkeit	
1 km/h	0.620 mph
Drehmoment	
1 Nm	0.740 ft.lbs

A nameplate listing the Model Number, Item Number, Revision, and Serial Number is attached to each unit. Please record the information found on this plate so it will be available should the nameplate become lost or damaged. When ordering parts or requesting service information, you will always be asked to specify the model, item number, revision number, and serial number of the unit.

Part Numbers appearing in boldface type are recommended spare parts. This means that these parts are subject to wear under normal operating conditions and may require periodic service or replacement. It is recommended that these items be stocked to meet the expected service requirements of this model. Actual stocking quantities of these and other parts used in more extensive repairs will depend on the service practices of each customer.

My machine's numbers are:



1. Model
2. Revision
3. Item No.
4. Serial No.

**Conversion table**

Volume unit	
1 ml	0.034 US fl.oz.
1 l	0.260 gal
Unit of length	
1 mm	0.039 in
1 m	3.280 ft
Weight	
1 kg	2.200 lbs
1 g	0.035 oz
Speed	
1 km/h	0.620 mph
Torque	
1 Nm	0.740 ft.lbs

Una placa de identificación con el modelo, número de referencia, nivel de revisión y número de serie ha sido añadida en cada máquina. Favor de anotar los datos en la placa en caso de que la placa de identificación sea destruida o perdida. En todos los pedidos para repuestos necesita siempre el modelo, el número de referencia, el nivel de revisión y el número de serie de la máquina en cuestión.

Los números de partes en negritas en las Listas Ilustradas de Partes son los repuestos recomendados, esto quiere decir que estas partes se desgastarán bajo circunstancias de funcionamiento normales y pueden requerir servicio periódico o su reemplazo. Se recomienda que el cliente mantenga un abastecimiento adecuado de estas partes para poder satisfacer la demanda requerida por el servicio a la máquina. La cantidad de repuestos que el cliente necesitará para reparaciones dependerá de la póliza de servicio de cada cliente.

Los números de mi máquina son:



1. Modelo
2. Nivel de revisión
3. Número de referencia
4. Número de Serie

**Tabla de conversión**

Unidad de volumen	
1 ml	0.034 US fl.oz.
1 l	0.260 gal
Unidad de longitud	
1 mm	0.039 in
1 m	3.280 ft
Peso	
1 kg	2.200 lbs
1 g	0.035 oz
Velocidad	
1 km/h	0.620 mph
Par de apriete	
1 Nm	0.740 ft.lbs

Une plaque signalétique mentionnant le modèle, le numéro de référence, le niveau de revision et le numéro de série est fixée sur chaque machine. Veuillez noter les informations relevées sur cette plaque de façon à ce qu'elles soient toujours disponibles si la plaque signalétique venait à être perdue ou endommagée. Lorsque vous commandez des pièces détachées ou vous sollicitez des informations après-vente, on vous demandera toujours de préciser le modèle, le numéro de référence, le niveau de revision et le numéro de série de la machine.

Les numéros de pièces imprimés en caractères gras dans les Listes des Pièces Détachées de ce manuel sont les pièces détachées recommandées par la Wacker. Cela veut dire que ces pièces sont sujettes à usure dans des conditions de travail normales et peuvent nécessiter de l'entretien ou leur remplacement. Nous recommandons que vous disposez d'un stock de ces pièces pour pouvoir satisfaire la demande d'entretien de cette machine. Le client doit décider lui-même de la quantité exacte de pièces de rechange qu'il disposera dans ses stocks.

Les numéros de ma machine son :

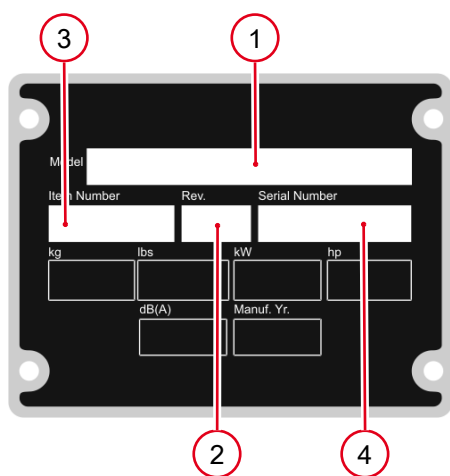

1. Typ
2. Version
3. Artikel-Nr.
4. Maschinen-Nr.

**Table de conversion**

Unité de volume	
1 ml	0.034 US fl.oz.
1 l	0.260 gal
Unité de longueur	
1 mm	0.039 in
1 m	3.280 ft
Poids	
1 kg	2.200 lbs
1 g	0.035 oz
Vitesse	
1 km/h	0.620 mph
Couple de serrage	
1 Nm	0.740 ft.lbs

Vibrationsplatte Vibration plate Plancha vibradora Plaque vibrante .....	12
---	----

Vibrationsplatte Vibration plate Plancha vibradora Plaque vibrante .....	14
---	----

Deichsel Skandinavien Ausführung Center pole scandinavia version Barra de mando escandinavia versión Timon scandinavie version .....	16
---	----

Obermasse Upper mass Masa superior Masse superieure .....	18
--	----

Batterieschutz Kpl. Battery protection cpl. Protección de batería cpl. Protection de batterie cpl. ....	22
--	----

Batteriedeckel Kpl. Battery cover cpl. Tapa de batería cpl. Couvercle de batterie cpl. ....	24
--	----

Untermasse Baseplate Masa inferior Masse inferieure .....	26
--	----

Erreger Exciter Excitador Excitatrice .....	28
--	----

Deichsel Kpl. Center pole cpl. Barra de mando cpl. Timon cpl. ....	32
---	----

Deichselkopf Kpl. Center pole head cpl. Cabezal de mando cpl. Tête de timon cpl. ....	36
--	----

Fliehkraftkupplung Centrifugal clutch Embrague Embrayage .....	38
---	----

Aufkleber Labels Calcomanías Autocollants .....	40
--	----

Wartungspaket Maintenance kit Juego para mantenimiento Jeu d'entretien .....	42
---	----

Motor L70V Engine I70v Motor I70v Moteur I70v	
--	--

Zylindergehäuse Cylinder housing Carcasa de cilindro Carter cylindre .....	44
---	----

Ölablass Oil drain Drenaje de aceite Raccord vidange d'huile .....	46
---	----

Zylinderkopf Cylinder head Culata Culasse .....	48
--	----

Luftfilter Air cleaner Filtro del aire Filtre à air .....	52
--	----

Vorfilter Prefilter Prefiltro Prefiltre .....	54
--	----

Auspuff Exhaust Escape Échappement .....	56
---	----

Nockenwelle Camshaft Arbol de levas Arbre à cames .....	58
--	----

Kurbelwelle Crankshaft Cigüeñal Vilebrequin .....	60
--	----

Schwungrad Fly wheel Volante Volant .....	62
--	----

Kolben, Pleuel Piston, connecting rod Pistón, biela, cilindro Piston, bielle .....	64
---	----



Ausgleichswelle Balancer shaft Arbol Arbre .....	66
Ölpumpe, Regler Oil pump, governor Bomba de aceite, regulador Pompe à huile, régulateur .....	68
Öldruckschalter Oil pressure switch Interruptor de presión de aceite Interrupteur à pression .....	70
Abdeckung Covering Cubierta Couverture .....	72
Lüftergehäuse Blower housing Carcasa de ventilador Carter aérateur .....	74
Einspritzpumpe, Einspritzventil Injection pump, injection valve Bomba de inyección, válvula inyectora Pompe à injection, soupape .....	76
Kraftstofftank, Kraftstoffleitungen Fuel tank, fuel pipes Depósito de combustible, tubería de combustible Réservoir à essence, tuyau .....	78
Regler Governor Regulador Régulateur .....	80
Reversierstarter Recoil starter Starter reversible Démarreur réversible .....	82
Starter Starter Starter Starter .....	84
Kabelbaum Cable harness Disp. del cable de elevación Faisceau de câbles .....	86
Dynamo Dynamo Dínamo Dynamo .....	88

Aufkleber Label Calcomania Autocollant .....	90
---	----

Dichtungssatz, Werkzeug Gasket set, tool Juego de juntas, herramienta Jeu de joints, outil .....	92
---	----

Zubehör  
 Accessories  
 Accesorios  
 Accessoires

Anbauplatten-Satz Extension plate kit Juego de placa de extensión Jeu de elargisseur .....	94
---	----

Anbauplatten-Satz Extension plate kit Juego de placa de extensión Jeu de elargisseur .....	96
---	----

Anbauplatten-Satz Extension plate kit Juego de placa de extensión Jeu de elargisseur .....	98
---	----

Schraubensatz Set of screws Juego de tornillos Jeu de vis .....	100
--	-----

Gleitvorrichtung PGV 4045-5545 Urethane pad pgv 4045-5545 Placa de deslizamientopgv 4045-5545 Jeu de tapis en polyuréthane .....	102
---	-----

Nachrüstsatz Rental DPU40../45../55.. Kit-retrofit dpu40../45../55.. Juego de modificación dpu40../45../55.. Lot de rattrapage .....	104
---	-----



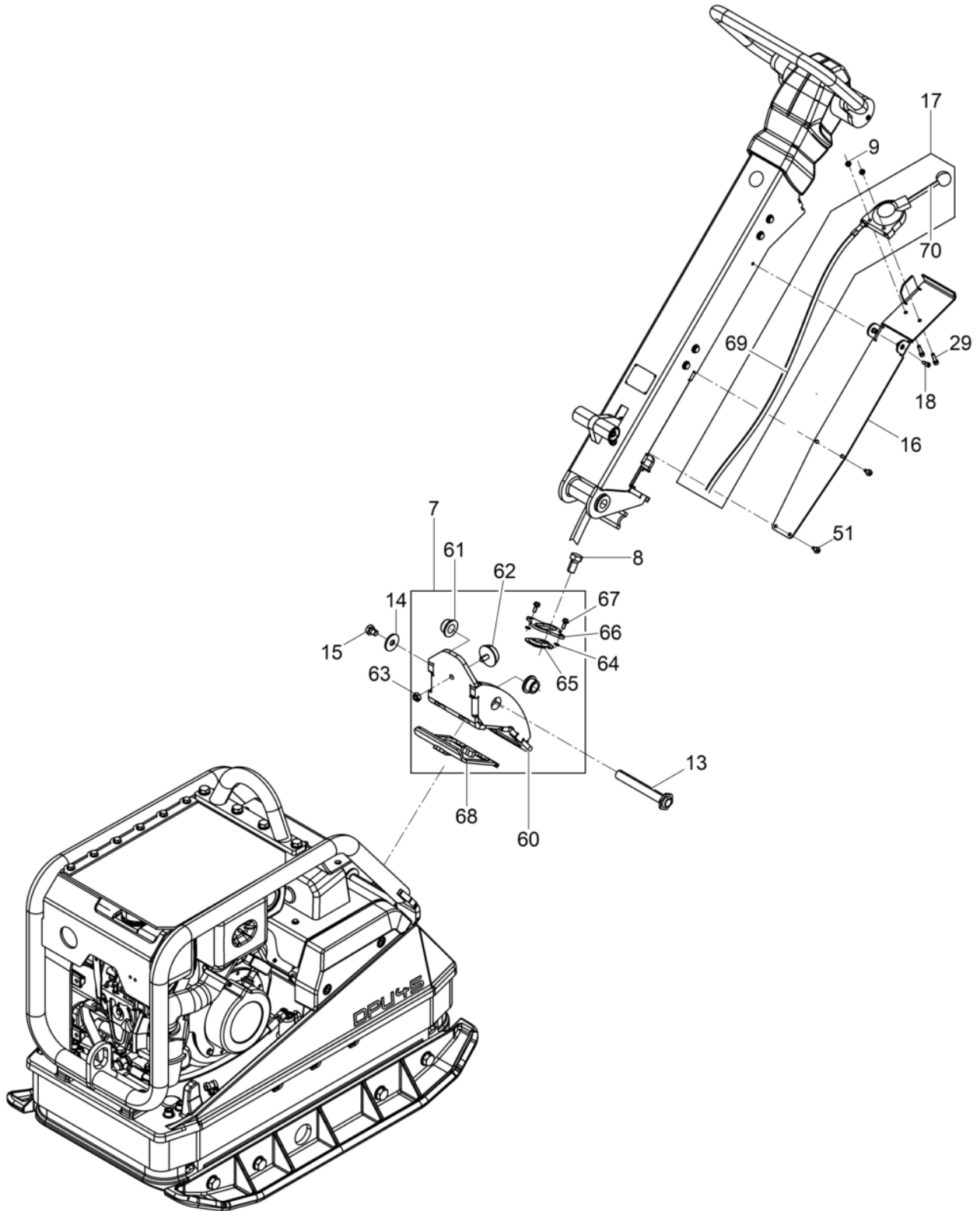

Pos. Item	Artikel Nr. Item no.	Pc.	Unit	Beschreibung Descripción	Description Description	Abm. Dim.	Norm Standard
						Drehmoment Torque	Schmierstoff Lubricant
7	5100010938	1	pc	Deichselbock Kpl. Caballete de apoyo cpl.	Support cpl. Support cpl.		
8	5000011523	4	pc	Sechskantschraube Tornillo hexagonal	Hexagonal head cap screw Vis à tête hexagonale	M16 x 30 210Nm/155ft.lbs	DIN933
9	5000010880	2	pc	Sechskantmutter Tuerca hexagonal	Hexagon nut Écrou hexagonal		
13	5100009632	1	pc	Achse Eje	Axle Axe		
14	5000010376	1	pc	Scheibe Arandela	Flat washer Rondelle		DIN9021
15	5000014316	1	pc	Sechskantschraube Tornillo hexagonal	Hexagonal head cap screw Vis à tête hexagonale	M12 x 16 86Nm/63ft.lbs	DIN933
16	5100009950	1	pc	Deckblech Kpl. Cubierta de chapa cpl.	Cover plate cpl. Coife cpl.		
17	5100041159	1	pc	Betätigung Regulador	Control Commande		
18	5000011553	2	pc	Zylinderschraube Tornillo cilíndrico	Cheese head screw Vis à tête cylindrique		
29	5000011550	2	pc	Zylinderschraube Tornillo cilíndrico	Cheese head screw Vis à tête cylindrique	M6 x 25 10Nm/7ft.lbs	ISO4762
51	5000204408	4	pc	Schraube Tornillo	Screw Vis	DE M 6x 16	DIN7500
60	5100003725	1	pc	Deichselbock Caballete de apoyo	Support Support		
61	5100051256	2	pc	Buchse Buje	Bush Boîte		
62	5100005558	2	pc	Anschlagpuffer Amortiguador	Shockmount Silentbloc	50 x 18 M10 x 20	
63	5000010883	1	pc	Sechskantmutter Tuerca hexagonal	Hexagon nut Écrou hexagonal		
64	5000010624	2	pc	Scheibe Arandela	Flat washer Rondelle		
65	5100010504	1	pc	Dichtung Junta	Gasket Joint		
66	5100010505	1	pc	Blech Chapa	Plate Tôle		
67	5000204408	2	pc	Schraube Tornillo	Screw Vis	DE M 6x 16	DIN7500
68	5100010503	1	pc	Dichtungsprofil Junta	Profiled joint Joint d'étanchéité profilé		
69	5100049577	1	pc	Betätigung Regulador	Control Commande		
70	5100049610	1	pc	Geber Acelerador	Throttle Levier regulateur		

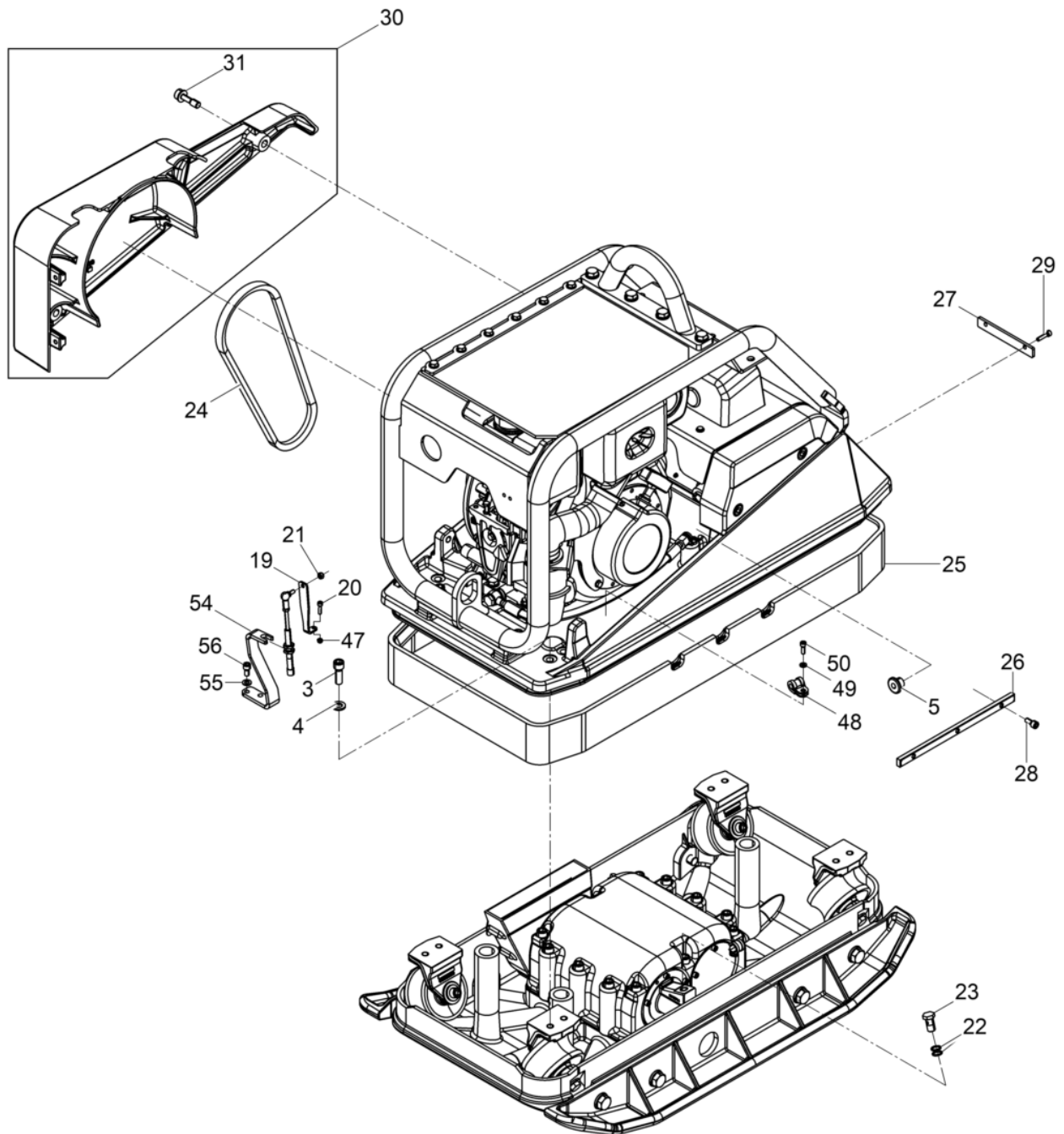

Pos. Item	Artikel Nr. Item no.	Pc.	Unit	Beschreibung Descripción	Description Description	Abm. Dim.	Norm Standard
						Drehmoment Torque	Schmierstoff Lubricant
3	5000011528	8	pc	Zylinderschraube Tornillo cilíndrico	Cheese head screw Vis à tête cylindrique	M12 x 35 86Nm/63ft.lbs	ISO4762
4	5000021465	8	pc	Sicherungsscheibe Arandela de seguridad	Lock washer Rondelle d'arrêt	HS12	
5	5000103880	1	pc	Rohrdurchführung Tubo de guía	Pipe guide Passage de tuyau		
19	5100013738	1	pc	Blech Chapa	Plate Tôle		
20	5000017908	1	pc	Zylinderschraube Tornillo cilíndrico	Cheese head screw Vis à tête cylindrique	M5 x 20 10Nm/7ft.lbs	ISO4762
21	5000021679	1	pc	Sechskantmutter Tuerca hexagonal	Hexagon nut Écrou hexagonal	M6	DIN980
22	5000012624	2	pc	Dichtring Anillo de junta	Gasket Bague d'étanchéité	A14 x 18	DIN7603
23	5000043201	1	pc	Hohlschraube Perno hueco	Banjo bolt Boulon creux à filet femelle	10-3	DIN7643
24	5100052270	1	pc	Keilriemen Correa en v	V-belt Courroie		
25	5100009634	1	pc	Schürze Protección	Apron Tablier		
26	5000097110	1	pc	Leiste Listón	Bar Listeau		
27	5100009635	1	pc	Leiste Listón	Bar Listeau		
28	5000103962	6	pc	Zylinderschraube Tornillo cilíndrico	Cheese head screw Vis à tête cylindrique	M8 x 18 25Nm/18ft.lbs	ISO4762
29	5000011550	2	pc	Zylinderschraube Tornillo cilíndrico	Cheese head screw Vis à tête cylindrique	M6 x 25 10Nm/7ft.lbs	ISO4762
30	5100002779	1	pc	Riemenschutz Protección de la polea	Belt guard Protection de courroie		
31	5000220202	3	pc	Dünnschaftschraube Tornillo	Screw Vis	M12x 40	
47	5000017312	1	pc	Sechskantmutter Tuerca hexagonal	Hexagon nut Écrou hexagonal	M5	DIN980
48	5000096691	1	pc	Rohrschelle Abrazadera	Pipe clamp Collier pour tuyau		
49	5000010624	1	pc	Scheibe Arandela	Flat washer Rondelle		
50	5000011552	1	pc	Zylinderschraube Tornillo cilíndrico	Cheese head screw Vis à tête cylindrique	M6 x 18 10Nm/7ft.lbs	ISO4762
54	5100013657	1	pc	Blech Chapa	Plate Tôle		
55	5000010622	2	pc	Scheibe Arandela	Flat washer Rondelle		
56	5000011544	2	pc	Zylinderschraube Tornillo cilíndrico	Cheese head screw Vis à tête cylindrique	25Nm/18ft.lbs	ISO4762

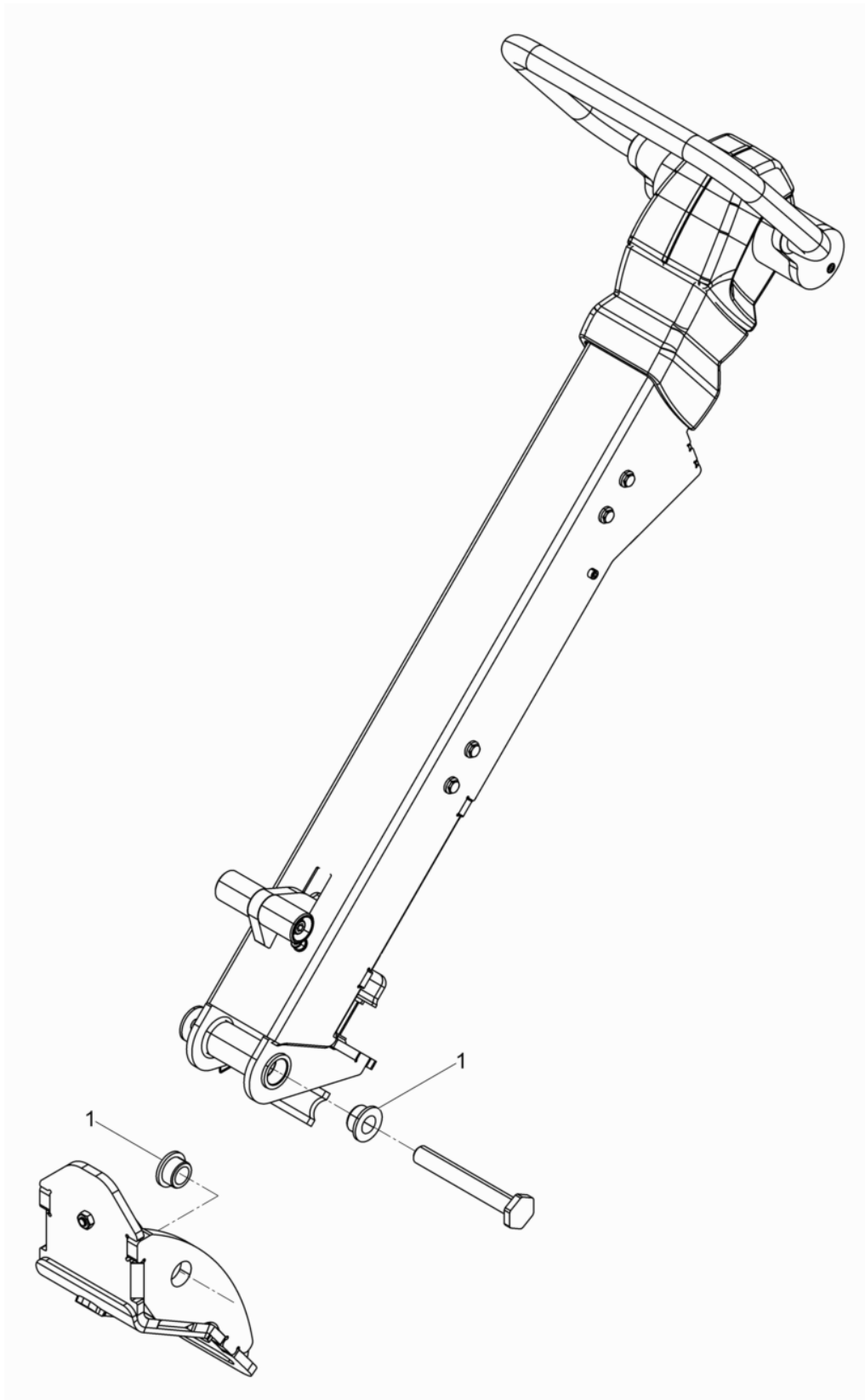



Pos. Item	Artikel Nr. Item no.	Pc.	Unit	Beschreibung Descripción	Description Description	Abm. Dim.	Norm Standard
						Drehmoment Torque	Schmierstoff Lubricant
1	5100042458	4	pc	Messingbuchse Buje de latón	Brass bush Boîte en laiton		

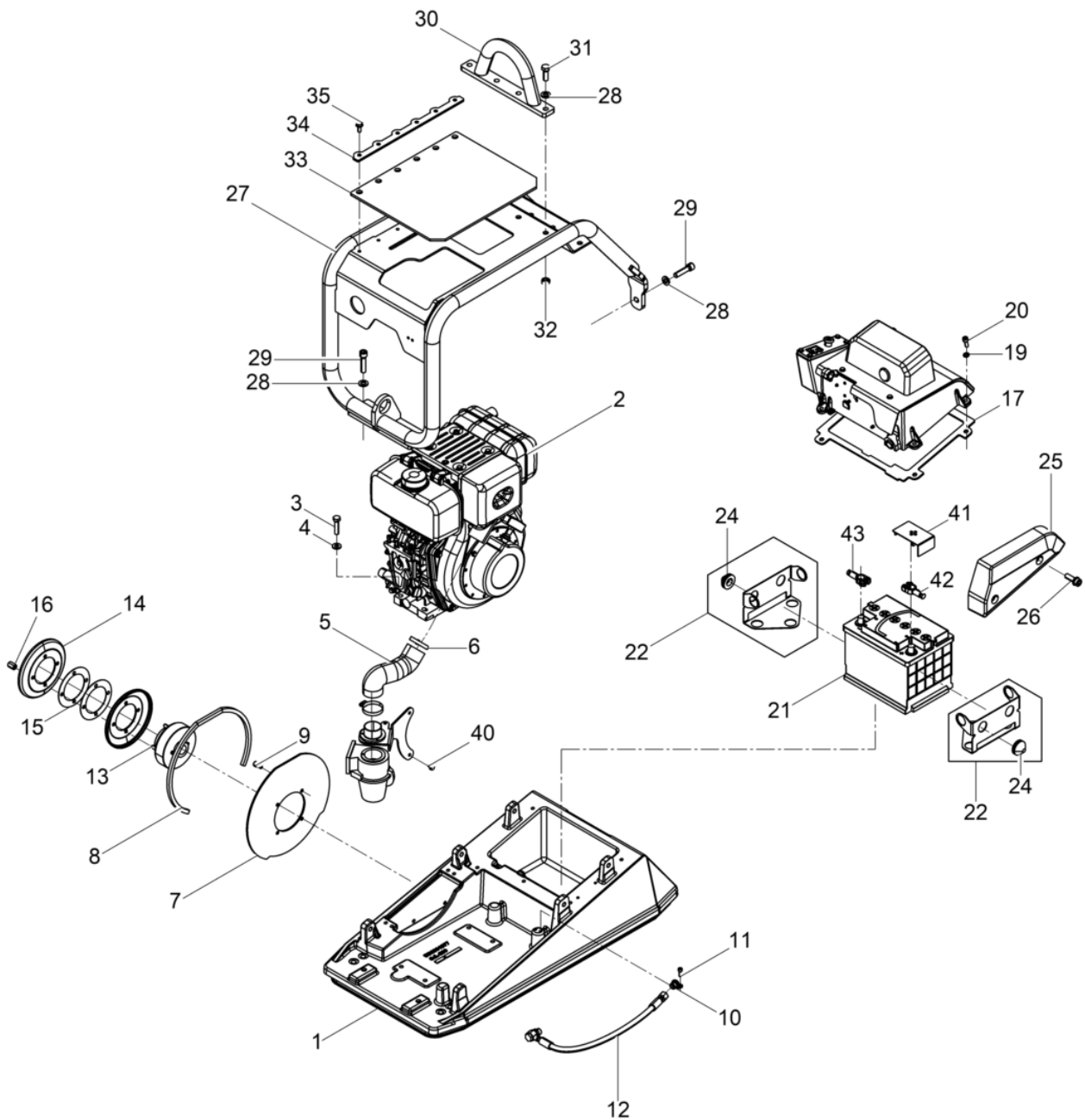

Pos. Item	Artikel Nr. Item no.	Pc.	Unit	Beschreibung Descripción	Description Description	Abm. Dim.	Norm Standard
						Drehmoment Torque	Schmierstoff Lubricant
1	5100005497	1	pc	Obermasse Masa superior	Upper mass Masse superieure		
2	5100060310	1	pc	Dieselmotor Motor diesel	Diesel engine Moteur diesel		
3	5000011436	4	pc	Sechskantschraube Tornillo hexagonal	Hexagonal head cap screw Vis à tête hexagonale	M10 x 45 49Nm/36ft.lbs	DIN933
4	5000033988	4	pc	Spannscheibe Arandela elástica	Lockwasher Rondelle de ressort		DIN6796
5	5000216568	1	pc	Ansaugschlauch Manguera de succión	Suction hose Tuyau de succion		
6	5000058009	2	pc	Schneckenengewindeschelle Abrazadera con sinfín	Worm drive hose clip Collier de serrage	40- 60/12	
7	5000204558	1	pc	Blech Chapa	Plate Tôle		
8	5000204807	1	pc	Gummiprofil Perfil de goma	Rubber profile Profil en caoutchouc		
9	5000011544	4	pc	Zylinderschraube Tornillo cilíndrico	Cheese head screw Vis à tête cylindrique	25Nm/18ft.lbs	ISO4762
10	5000206414	1	pc	Fixierung Fijación	Fixation Fixation		
11	5000011552	2	pc	Zylinderschraube Tornillo cilíndrico	Cheese head screw Vis à tête cylindrique	M6 x 18 10Nm/7ft.lbs	ISO4762
12	5000216576	1	pc	Ölablass Kpl. Drenaje de aceite cpl.	Oil drain cpl. Raccord vidange d'huile cpl.		
13	5000209499	1	pc	Fliehkraftkupplung Embrague	Centrifugal clutch Embrayage		
14	5000209508	2	pc	Keilriemenscheibenhälfte Semi-polea en v	V-belt pulley half Flanc de poulie à courroie		
15	5000058668	2	pc	Distanzscheibe Distanciador	Distance washer Disque d'écartement		
16	5000204806	4	pc	Sechskantmutter Contratuerca	Locknut Contre-écrou		
17	5000220232	1	pc	Dichtung Junta de estanqueidad	Gasket Garniture		
19	5000010742	4	pc	Scheibe Arandela	Washer Rondelle		
20	5000012629	4	pc	Zylinderschraube Tornillo cilíndrico	Cheese head screw Vis à tête cylindrique		
21	5100021329	1	pc	Batterie Batería	Battery Batterie		
22	5100011287	1	pc	Batterieprotector Kpl. Protección de batería cpl.	Battery protection cpl. Protection de batterie cpl.		
24	5000124255	16	pc	Batteriepuffer Tope	Shockmount Tampon		
25	5000220336	1	pc	Seitendeckel Links Cubierta	Side cap Couvercle		
26	5000220325	2	pc	Sicherungsschraube Tornillo	Screw Vis	M 12x 35	
27	5000209502	1	pc	Schutzrahmen Armazón de protección	Protective frame Cadre protection		
28	5000021465	8	pc	Sicherungsscheibe Arandela de seguridad	Lock washer Rondelle d'arrêt	HS12	
29	5000013569	4	pc	Zylinderschraube Tornillo cilíndrico	Cheese head screw Vis à tête cylindrique	M12 x 50 86Nm/63ft.lbs	ISO4762
30	5000103930	1	pc	Öse Punto de izaje	Hook Crochet		

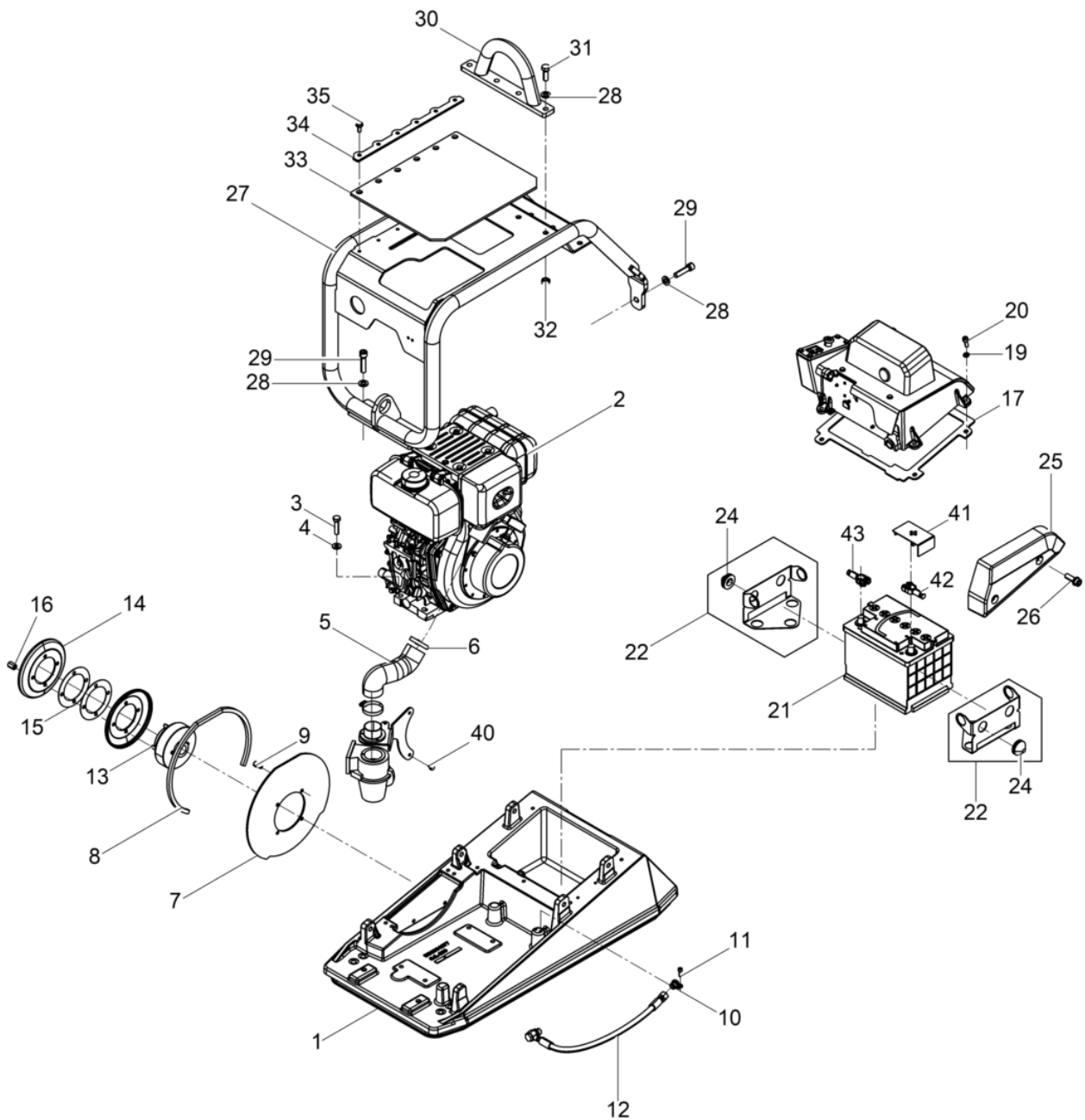

Pos. Item	Artikel Nr. Item no.	Pc.	Unit	Beschreibung Descripción	Description Description	Abm. Dim.	Norm Standard
						Drehmoment Torque	Schmierstoff Lubricant
31	5000011422	4	pc	Sechskantschraube Tornillo hexagonal	Hexagonal head cap screw Vis à tête hexagonale	M12 x 35 86Nm/63ft.lbs	DIN933
32	5000010366	4	pc	Sechskantmutter Tuerca hexagonal	Hexagon nut Écrou hexagonal	M12X1.75	DIN985
33	5000102011	1	pc	Abdeckplatte Placa de cubierta	Cover plate Plaque de recouvrement		
34	5000099915	1	pc	Leiste Listón	Bar Listeau		
35	5000105944	6	pc	Schraube Tornillo	Screw Vis	DE M8 x 20	DIN7500
40	5000011554	2	pc	Zylinderschraube Tornillo cilíndrico	Cheese head screw Vis à tête cylindrique		
41	5100011307	1	pc	Pluspol-Abdeckung Cubierta	Positive pol cover Couverture		
42	5100015202	1	pc	Polklemme Pluspol Terminal de polo positivo	Pole terminal positive Borne polaire positive		
43	5100015203	1	pc	Polklemme Minuspol Terminal de polo negativo	Pole terminal negative Borne polaire negative		

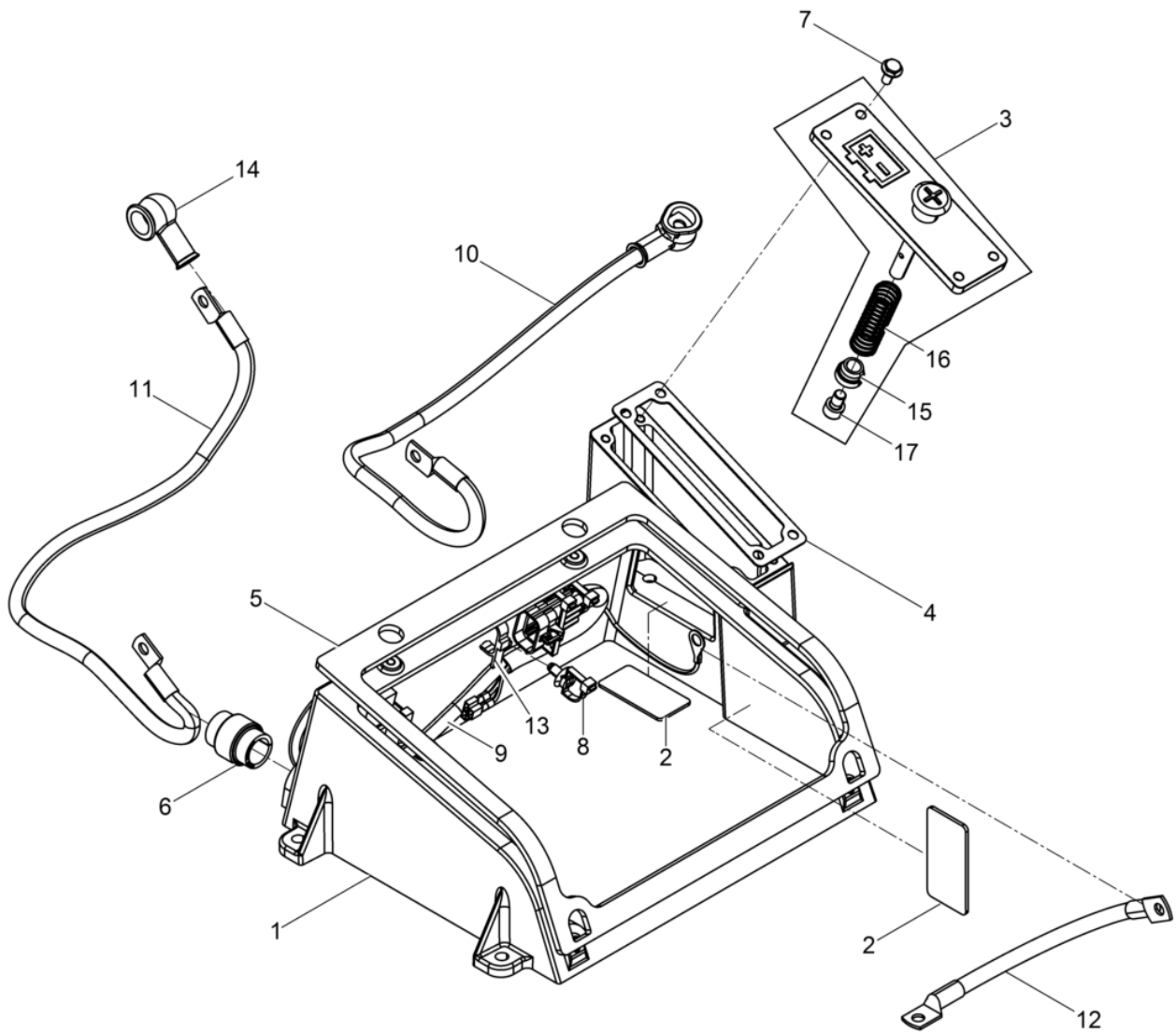

Pos. Item	Artikel Nr. Item no.	Pc.	Unit	Beschreibung Descripción	Description Description	Abm. Dim.	Norm Standard
						Drehmoment Torque	Schmierstoff Lubricant
1	5100011289	1	pc	Batterieschutz Protección de batería	Battery protection Protection de batterie		
2	5100010149	2	pc	Pad Cojín	Pad Coussin		
3	5100011304	1	pc	Starthilfe Kpl. Embolo buzo cpl.	Starting device cpl. Fouloir plongeur cpl.		
4	5000216678	1	pc	Dichtung Junta de estanqueidad	Gasket Garniture		
5	5000220233	1	pc	Dichtung Junta de estanqueidad	Gasket Garniture		
6	5000220432	1	pc	Einsatz Inserto	Insert Insertion		
7	5000210194	4	pc	Sicherungsschraube Tornillo	Corrugated-head screw Vis		
8	5100011341	7	pc	Kabelbinder Fijación	Tie cable Attache		
9	5100013772	1	pc	Kabelbaum Disp. del cable de elevación	Cable harness Faisceau de câbles		
10	5100010865	1	pc	Fremdstarterkabel Cable	Battery boost cable Câble		
11	5100015100	1	pc	Plus-Pol-Leitung Cable polo positivo	Positive pole strap Ligne borne positive		
12	5100010866	1	pc	Minus-Pol-Leitung Cable polo negativo	Negative pole strap Ligne borne négative		
13	5000047388	1	pc	Kabelbinder Fijación de cables	Zip tie Attache de câble		
14	5000058696	1	pc	Verschlusskappe Tapa de cierre	Nose cap Chape de fermeture		
15	5100009601	1	pc	Buchse Buje	Bush Boîte		
16	5100011308	1	pc	Druckfeder Resorte de compresión	Compression spring Ressort de pression	1x17,5x100x8,5	
17	5000013574	1	pc	Zylinderschraube Tornillo cilíndrico	Cheese head screw Vis à tête cylindrique	25Nm/18ft.lbs	

Batteriedeckel Kpl.  
Battery cover cpl.  
Tapa de batería cpl.  
Couvercle de batterie cpl.

DPU45Yeh EU

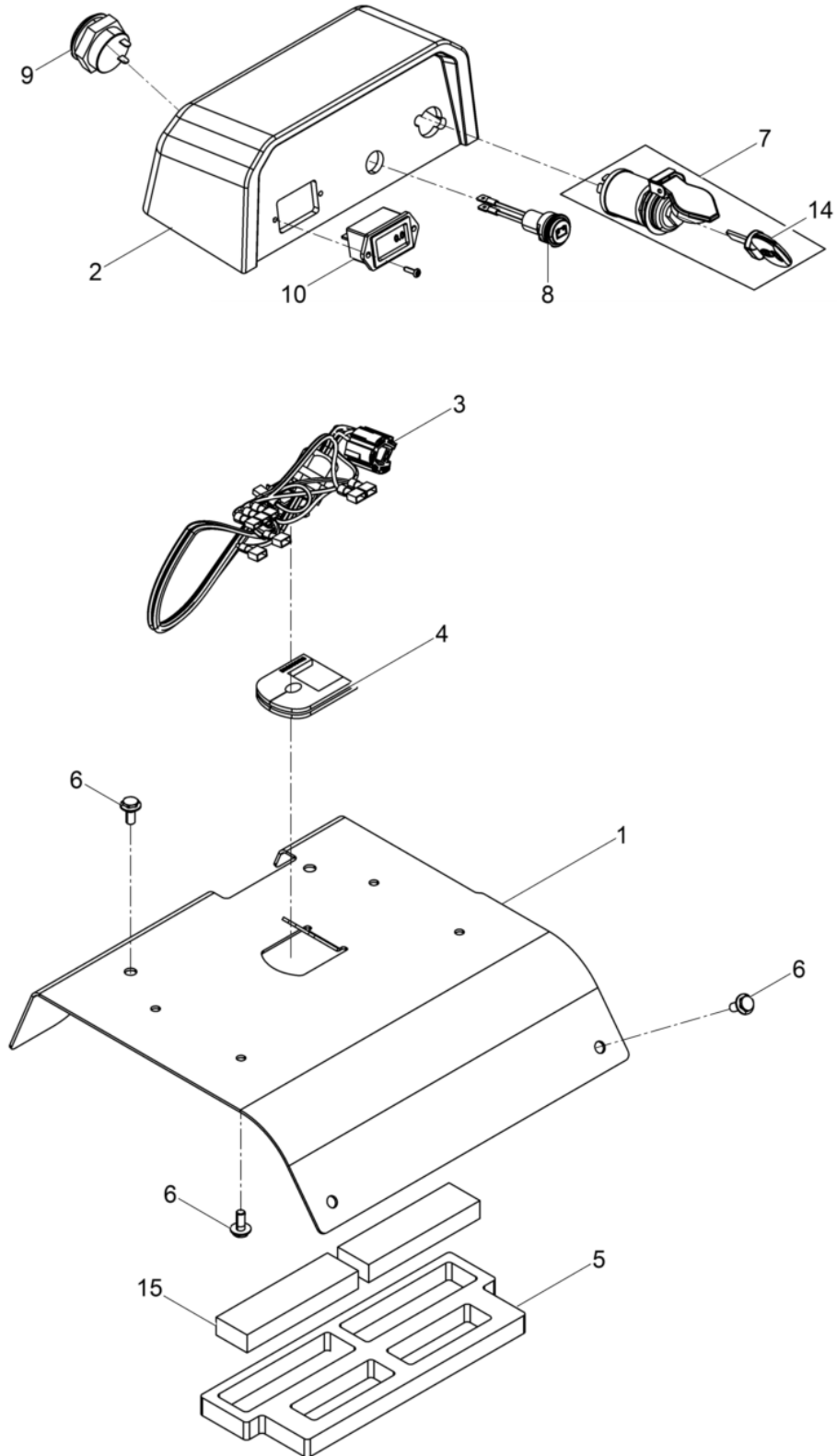



Pos. Item	Artikel Nr. Item no.	Pc.	Unit	Beschreibung Descripción	Description Description	Abm. Dim.	Norm Standard
						Drehmoment Torque	Schmierstoff Lubricant
1	5100020824	1	pc	Batteriedeckel Protección de batería	Battery cover Couvercle de batterie		
2	5100010085	1	pc	Gehäuse Carcasa	Housing Carter		
3	5100013773	1	pc	Spiralkabel Cable espiral	Helix cable Câble spirale		
4	5100009911	1	pc	Dichtung Junta	Gasket Joint		
5	5100020556	1	pc	Kissen Für Batterie Almohadilla	Insulating cushion Coussin		
6	5000210194	8	pc	Sicherungsschraube Tornillo	Corrugated-head screw Vis		
7	5100011296	1	pc	Zündanlassschalter Interruptor de arranque	Ignition starter switch Interrupteur démarreur		
8	5000129797	1	pc	LED Leuchte Diodo	Led Diode luminescente		
9	5000220234	1	pc	Signalgeber Señal acústica	Acoustic signal Signal acoustique		
10	5100011309	1	pc	Betriebsstundenzähler Carter del motor	Working hour meter Carter de moteur		
14	5000220118	1	pc	Schlüssel Llave	Key Clé		
15	5100020618	2	pc	Filtermatte Esterá filtrante	Filter mat Élément filtrant		

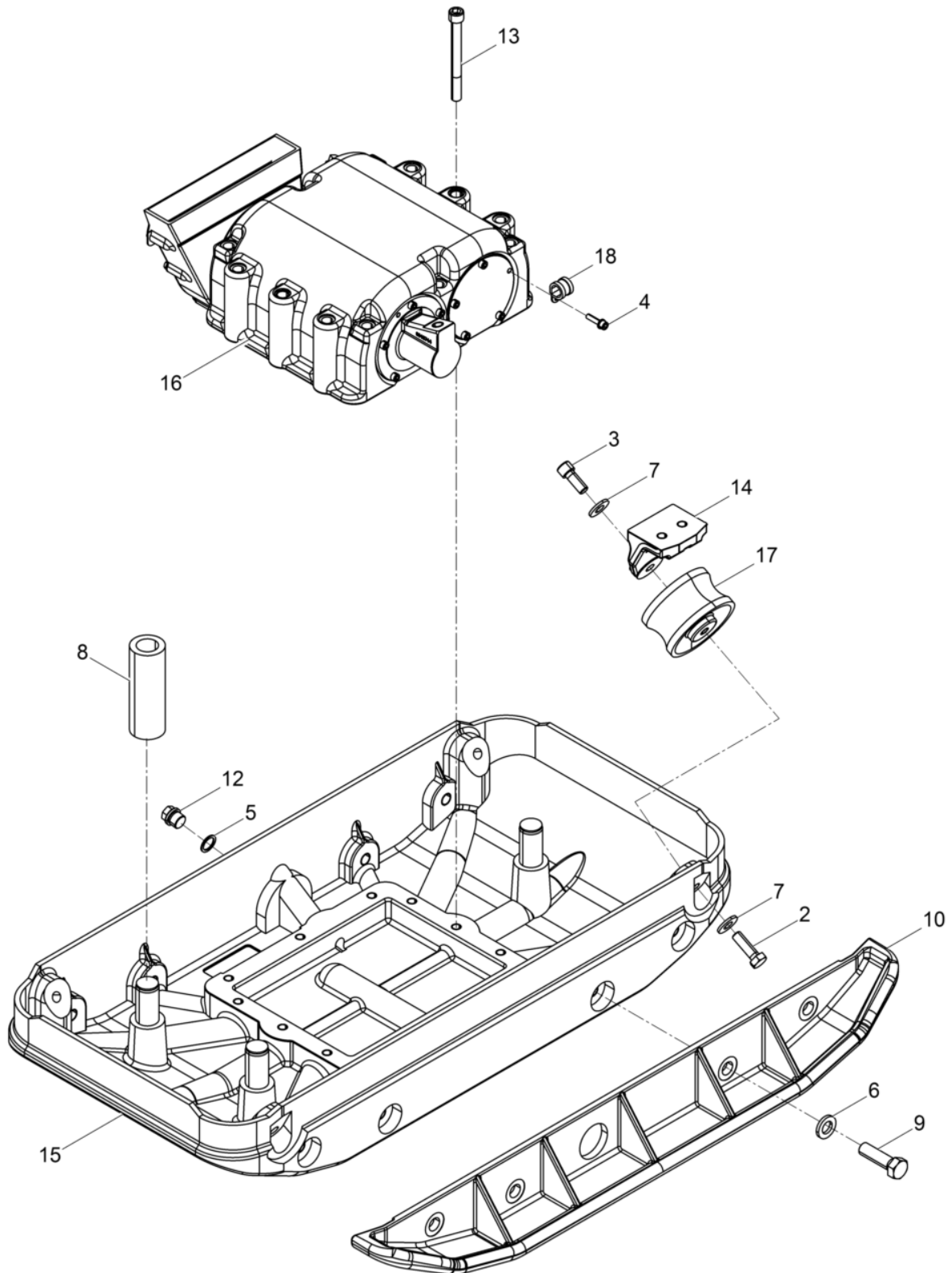

Pos. Item	Artikel Nr. Item no.	Pc.	Unit	Beschreibung Descripción	Description Description	Abm. Dim.	Norm Standard
						Drehmoment Torque	Schmierstoff Lubricant
2	5000011421	4	pc	Sechskantschraube Tornillo hexagonal	Hexagonal head cap screw Vis à tête hexagonale	M12 x 40 86Nm/63ft.lbs	DIN933
3	5000011529	4	pc	Zylinderschraube Tornillo cilíndrico	Cheese head screw Vis à tête cylindrique	M12 x 30 86Nm/63ft.lbs	ISO4762
4	5100072823	1	pc	Kombi-Schraube M 6X 25 Tornillo m 6x 25	Screw m 6x 25 Vis m 6x 25	10Nm/7ft.lbs	
5	5000019156	1	pc	Dichtring Anillo de junta	Gasket Bague d'étanchéité		
6	5000021988	8	pc	Sicherungsscheibe Arandela de seguridad	Lock washer Rondelle d'arrêt	HS16	
7	5000031565	8	pc	Spannscheibe Arandela elástica	Lockwasher Rondelle de ressort		DIN6796
8	5000034442	3	pc	Dämpfungsbuchse Buje	Bushing Douille		
9	5000039191	8	pc	Sechskantschraube Tornillo hexagonal	Hexagonal head cap screw Vis à tête hexagonale	M16 x 1,5 x 55 210Nm/155ft.lbs	DIN961
10	5000044442	2	pc	Anbauplatte Placa de extensión	Extension plate Elargisseur	8 cm	
12	5000068222	1	pc	Verschlusschraube Tapón roscado	Plug (threaded) Bouchon		
13	5000094518	12	pc	Zylinderschraube Tornillo cilíndrico	Cheese head screw Vis à tête cylindrique	M12 x 120 120Nm/89ft.lbs	ISO4762
14	5000102105	4	pc	Pufferbock Soporte tope	Support Support d'amortisseur		
15	5000102356	1	pc	Untermasse Masa inferior	Baseplate Masse inferieure		
16	5000220163	1	pc	Erreger Kpl. Excitador cpl.	Exciter cpl. Excitateur cpl.		
17	5002004814	4	pc	Gimetal-Kerblager Mit Bund Amortiguador	Shockmount Silentbloc		
18	5000017123	1	pc	Rohrschelle Abrazadera	Pipe clamp Collier pour tuyau		

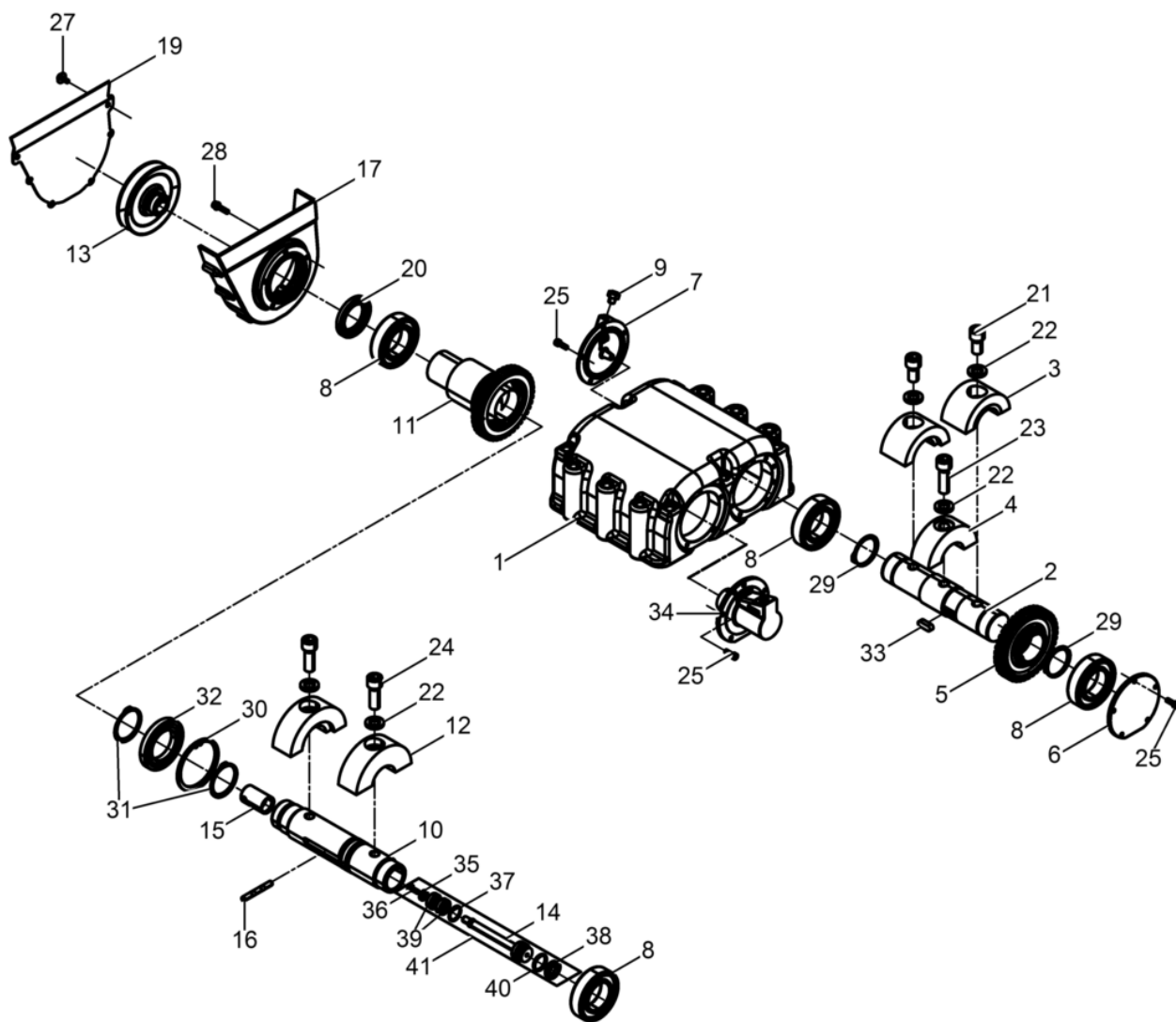

Pos. Item	Artikel Nr. Item no.	Pc.	Unit	Beschreibung Descripción	Description Description	Abm. Dim.	Norm Standard
						Drehmoment Torque	Schmierstoff Lubricant
1	5000099059	1	pc	Erregergehäuse Carcasa del excitador	Exciter housing Carter excitateur		
2	5000220059	1	pc	Welle Árbol	Shaft Arbre		
3	5000220082	2	pc	Unwucht Masa excéntrica	Eccentric weight Balourd		
4	5000220168	1	pc	Unwucht Masa excéntrica	Eccentric weight Balourd		
5	5000039116	1	pc	Zahnrad Engranaje	Gear wheel Roue dentée		
6	5000039110	1	pc	Deckel Tapa	Cover Couvercle		
7	5000102144	1	pc	Belüftungsdeckel Tapa de ventilación	Vent cover Couvercle d'aeration		
8	5000103469	4	pc	Zylinderrollenlager Rodamiento cilíndricos	Cylindrical roller bearing Roulement à rouleaux		
9	5001103030	1	pc	Entlüftungsschraube Tornillo de purga	Vent screw Vis d'évacuation d'air		
10	5000220077	1	pc	Welle Árbol	Shaft Arbre		
11	5000220053	1	pc	Verstellhülse Husillo de regulación	Adjusting sleeve Douille de réglage		
12	5000220170	2	pc	Unwucht Masa excéntrica	Eccentric weight Balourd		
13	5100076341	1	pc	Keilriemenscheibe Polea en v	V-belt pulley Poulie à courroie		
14	5000220079	1	pc	Bolzen Perno	Bolt Boulon		
15	5000220106	1	pc	Schaltbolzen Perno fijador	Indexing bolt Boulon		
16	5000043382	1	pc	Schaltstift Espiga de mando	Tripping pin Broche de manoeuvre		
17	5000102724	1	pc	Riemenschutz Protección de la polea	Belt guard Protection de courroie		
19	5000102721	1	pc	Abdeckblech Cubierta de chapa	Cover plate Tôle de recouvrement		
20	5000048854	1	pc	Wellendichtring Anillo de retén radial	Rotary shaft seal Bague d'étanchéité	48 x 72 x 7,4	
21	5000044634	2	pc	Zylinderschraube Tornillo cilíndrico	Cheese head screw Vis à tête cylindrique	M16 x 30 295Nm/218ft.lbs	ISO4762
22	5000021988	5	pc	Sicherungsscheibe Arandela de seguridad	Lock washer Rondelle d'arrêt	HS16	
23	5000043812	1	pc	Zylinderschraube Tornillo cilíndrico	Cheese head screw Vis à tête cylindrique	M16 x 50 295Nm/218ft.lbs	ISO4762
24	5000126300	2	pc	Zylinderschraube Tornillo cilíndrico	Cheese head screw Vis à tête cylindrique	M16 x 45 295Nm/218ft.lbs	ISO4762
25	5000011552	14	pc	Zylinderschraube Tornillo cilíndrico	Cheese head screw Vis à tête cylindrique	M6 x 18 10Nm/7ft.lbs	ISO4762
27	5100009501	6	pc	Kombi-Schraube Tornillo	Screw Vis	M6 x 16 10Nm/7ft.lbs	
28	5100072823	5	pc	Kombi-Schraube M 6X 25 Tornillo m 6x 25	Screw m 6x 25 Vis m 6x 25	10Nm/7ft.lbs	
29	5002006113	2	pc	Sicherungsring Anillo de retención	Retaining ring Bague d'arrêt		
30	5002007057	1	pc	Sicherungsring Anillo de retención	Retaining ring Bague d'arrêt	90 x 3	DIN472

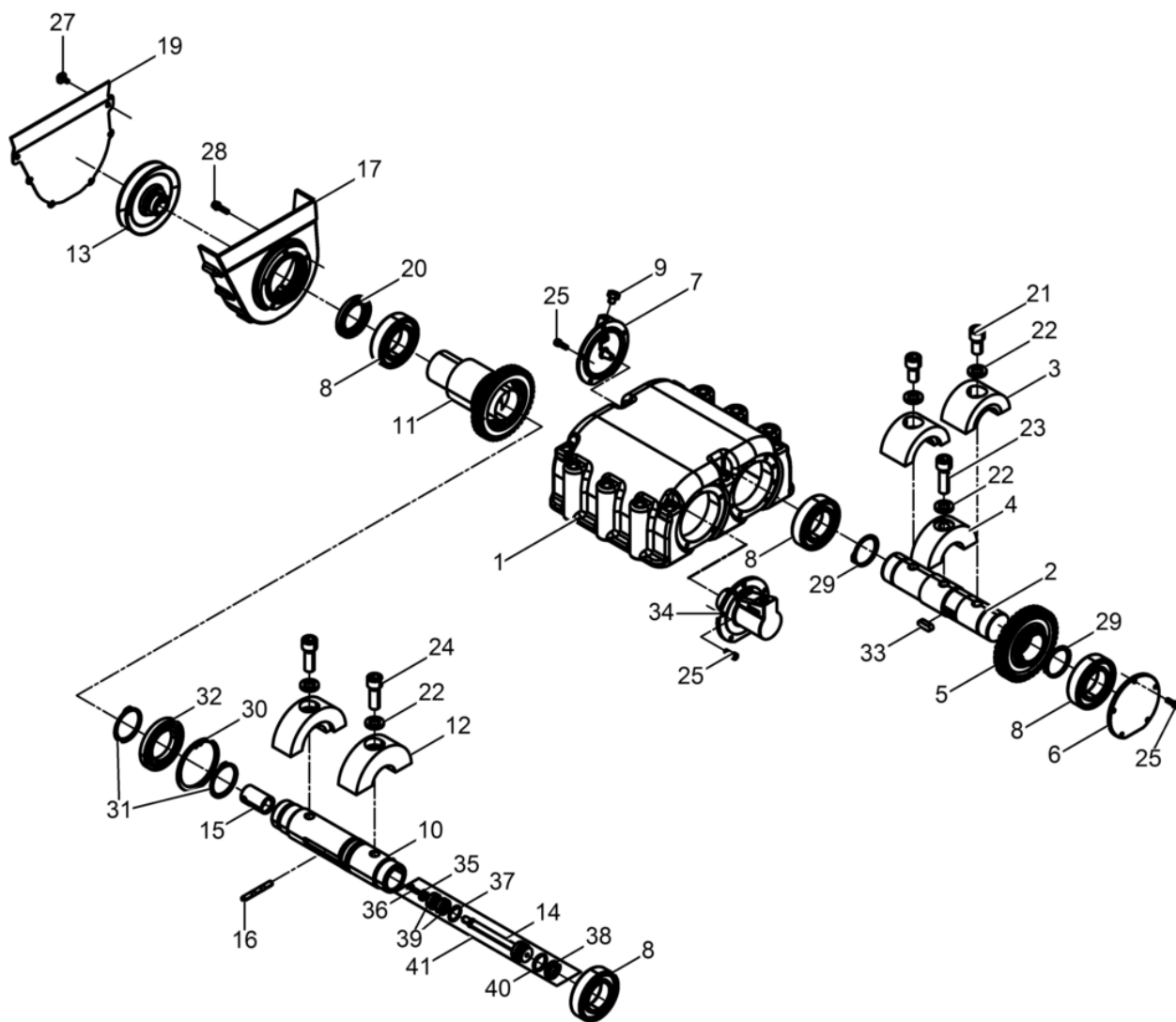

Pos. Item	Artikel Nr. Item no.	Pc.	Unit	Beschreibung Descripción	Description Description	Abm. Dim.	Norm Standard
						Drehmoment Torque	Schmierstoff Lubricant
31	5002004822	2	pc	Sicherungsring Anillo de retención	Retaining ring Bague d'arrêt	55 x 2	DIN471
32	5000220133	1	pc	Rillenkugellager Rodamiento a bolas	Grooved ball bearing Roulement rainuré à billes		DIN625
33	5002001399	1	pc	Passfeder Chaveta	Fitting key Clavette	A10 x 8 x 28	DIN6885
34	5000048604	1	pc	Zylinderdeckel Tapa del cilindro	Cylinder cover Couvercle de cylindre		
35	5000124717	1	pc	Scheibe Arandela	Washer Rondelle		
36	5000014663	1	pc	Sechskantschraube Tornillo hexagonal	Hexagonal head cap screw Vis à tête hexagonale	10Nm/7ft.lbs	DIN933
37	5000220384	1	pc	Sicherungsring Anillo de retención	Retaining ring Bague d'arrêt	26x 1,20	DIN472
38	5000043203	1	pc	Gummilippenring Reten labial de goma	Lip seal ring Bague en caoutchouc	30 x 20 x 6	
39	5000220383	2	pc	Rillenkugellager Rodamiento a bolas	Grooved ball bearing Roulement rainuré à billes		DIN625
40	5002006991	1	pc	O-Ring Anillo-o	O-ring Bague-o	24 x 3	
41	5000220081	1	pc	Bolzen Kpl. Perno cpl.	Bolt cpl. Boulon cpl.		

Deichsel Kpl.  
Center pole cpl.  
Barra de mando cpl.  
Timon cpl.

DPU45Yeh EU

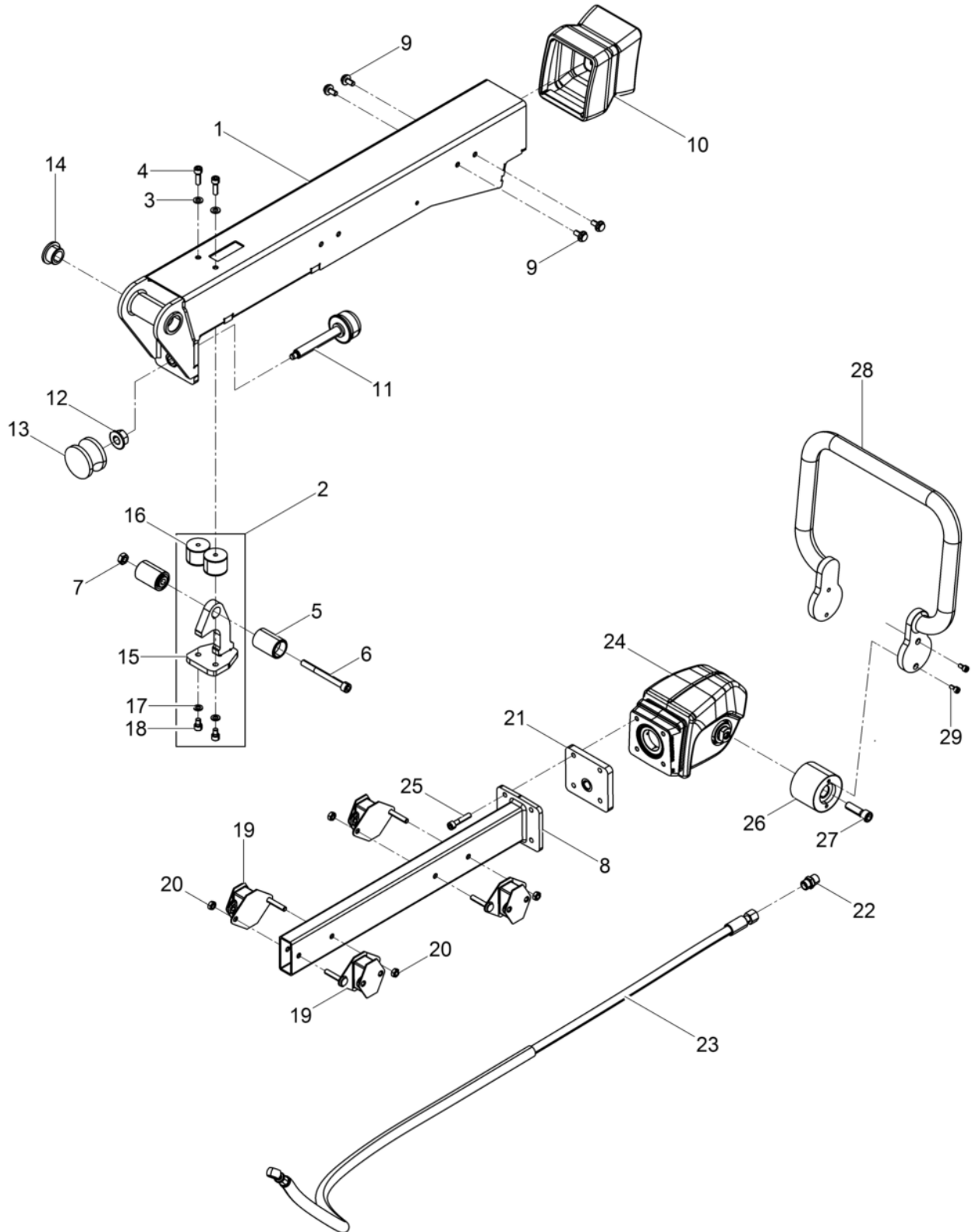



Pos. Item	Artikel Nr. Item no.	Pc.	Unit	Beschreibung Descripción	Description Description	Abm. Dim.	Norm Standard
						Drehmoment Torque	Schmierstoff Lubricant
1	5100009952	1	pc	Deichselrohr Barra de mando tubo	Center pole tube Timon tube		
2	5100005543	1	pc	Arretierung Dispositivo de retención	Lock Dispositif d'arrêt		
3	5000010622	2	pc	Scheibe Arandela	Flat washer Rondelle		
4	5000013574	2	pc	Zylinderschraube Tornillo cilíndrico	Cheese head screw Vis à tête cylindrique		
5	5100002007	2	pc	Arretierungsgriff Empuñadura de retención	Retaining handle Poignée d'arrêt		
6	5000037090	1	pc	Zylinderschraube Tornillo cilíndrico	Cheese head screw Vis à tête cylindrique	M10 x 100 49Nm/36ft.lbs	ISO4762
7	5000010883	1	pc	Sechskantmutter Tuerca hexagonal	Hexagon nut Écrou hexagonal		
8	5100005106	1	pc	Vierkantrohr Kpl. Tubo cuadrado cpl.	Square tube cpl. Tube carré cpl.		
9	5000211795	8	pc	Sicherungsschraube Tornillo	Corrugated-head screw Vis		
10	5100005538	1	pc	Faltenbalg Fuelle acordeón	Bellows Soufflet		
11	5000043928	1	pc	Gewindespindel Kpl. Husillo roscado cpl.	Threaded spindle cpl. Tige fileté cpl.		
12	5000202866	1	pc	Sechskantmutter Contratuerca	Locknut Contre-écrou	M16	EN1661
13	5000043233	1	pc	Gummi-Metall-Kerbpuffer Tope caucho-metal	Shockmount Tampon métallique oscillant	60 x 40	
14	5100051255	2	pc	Buchse Buje	Bush Boîte		
15	5100005541	1	pc	Arretierung Dispositivo de retención	Lock Dispositif d'arrêt		
16	5000129818	2	pc	Gummi-Metall-Puffer Tope caucho-metal	Shockmount Tampon métallique oscillant		
17	5000010742	2	pc	Scheibe Arandela	Washer Rondelle		
18	5000011543	2	pc	Zylinderschraube Tornillo hueco	Socket head screw Vis à six-pans creux	24Nm/18ft.lbs	ISO4762
19	5100010497	4	pc	Gummipuffer Tope caucho-metal	Shockmount Tampon oscillant		
20	5000010882	4	pc	Sechskantmutter Tuerca hexagonal	Hexagon nut Écrou hexagonal		
21	5100005526	1	pc	Flansch Brida	Flange Bride		
22	5000069225	1	pc	Einschraubstutzen Empalme roscado	Screwed socket Manchon visse		
23	5100005553	1	pc	Schlauchleitung Conducto flexible	Hose pipe Conduite flexible		
24	5100027083	1	pc	Deichselkopf Kpl. Cabezal de mando cpl.	Center pole head cpl. Tête de timon cpl.		
25	5000011539	4	pc	Zylinderschraube Tornillo cilíndrico	Cheese head screw Vis à tête cylindrique	M8 x 40 25Nm/18ft.lbs	ISO4762
26	5000215035	2	pc	Gummi-Metall-Puffer Tope caucho-metal	Shockmount Tampon métallique oscillant		
27	5000011527	2	pc	Zylinderschraube Tornillo cilíndrico	Cheese head screw Vis à tête cylindrique		
28	5100005124	1	pc	Bügel Abrazadera	Clamp Attache		

Deichsel Kpl.  
Center pole cpl.  
Barra de mando cpl.  
Timon cpl.

DPU45Yeh EU

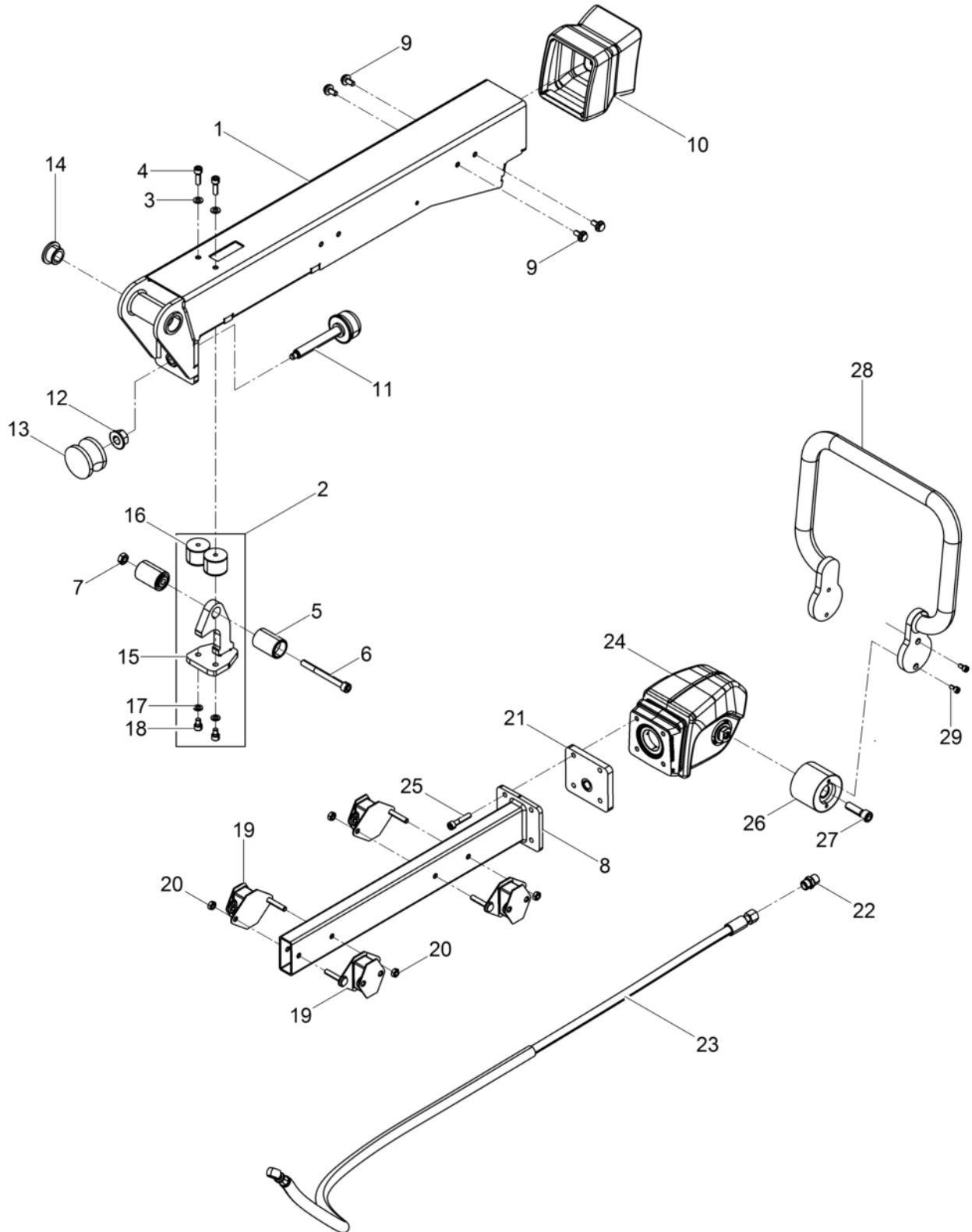

Pos. Item	Artikel Nr. Item no.	Pc.	Unit	Beschreibung Descripción	Description Description	Abm. Dim.	Norm Standard
						Drehmoment Torque	Schmierstoff Lubricant
29	5000011554	4	pc	Zylinderschraube Tornillo cilíndrico	Cheese head screw Vis à tête cylindrique		

Deichselkopf Kpl.  
Center pole head cpl.  
Cabezal de mando cpl.  
Tête de timon cpl.

DPU45Yeh EU

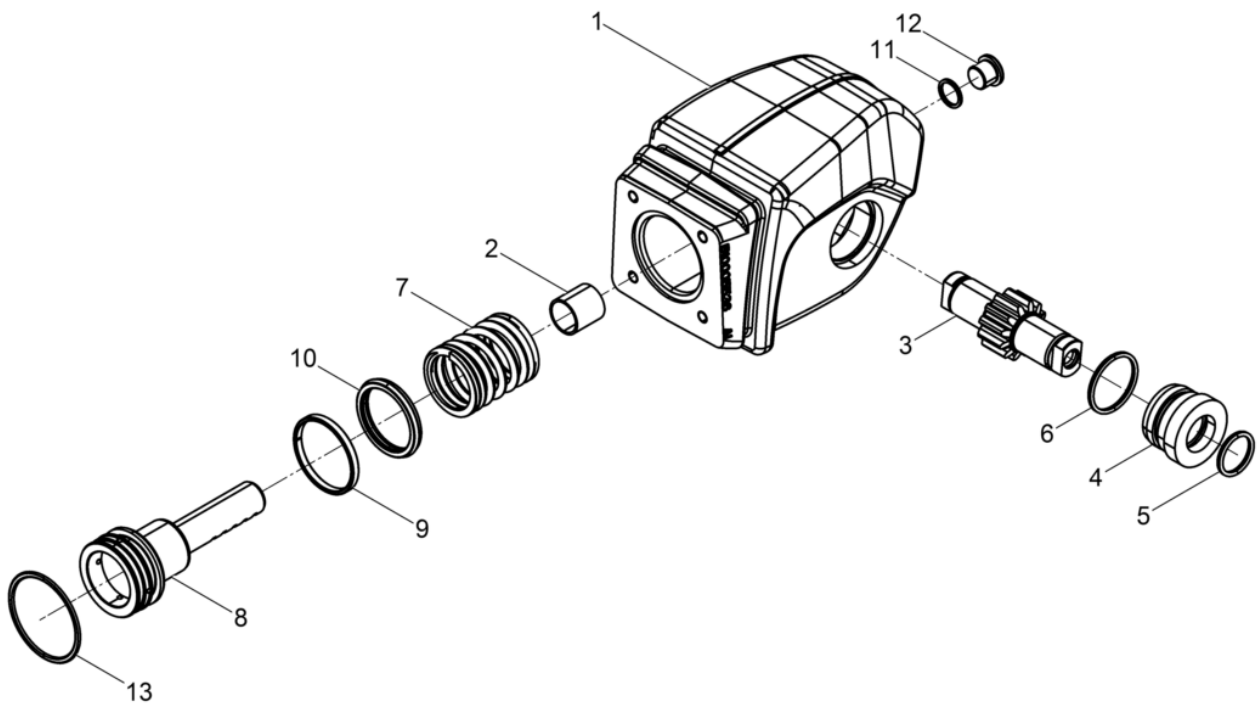

Pos. Item	Artikel Nr. Item no.	Pc.	Unit	Beschreibung Descripción	Description Description	Abm. Dim.	Norm Standard
						Drehmoment Torque	Schmierstoff Lubricant
1	5100005537	1	pc	Deichselkopf Cabezal de barra	Center pole head Tête de timon		
2	5000126164	1	pc	Gleitbuchse Buje deslizante	Slide bush Bôte de glissement		
3	5000069726	1	pc	Zahnradwelle Eje de rueda dentada	Long face pinion Arbre formant pignon		
4	5000125926	2	pc	Distanzstück Pieza distanciadora	Spacer Pièce d'écartement		
5	5000018194	2	pc	O-Ring Anillo-o	O-ring Bague-o		
6	5000068752	2	pc	O-Ring Anillo-o	O-ring Bague-o		
7	5100005559	1	pc	Druckfeder Resorte de compresión	Compression spring Ressort de pression		
8	5100005138	1	pc	Steuerkolben Pistón de mando	Control piston Piston de commande		
9	5100005532	1	pc	Führungsring Anillo guía	Guide ring Bague de guidage	KB 55x50x5,5 HG517	
10	5100005533	1	pc	Dichtung Junta	Gasket Joint		
11	5000012082	1	pc	Dichtungsring Anillo sellador	Seal ring Rondelle à étancher	A16 x 20	DIN7603
12	5000011050	1	pc	Verschlusschraube Tapón roscado	Plug (threaded) Bouchon	M16 x 1,5	DIN908
13	5000039235	1	pc	O-Ring Anillo-o	O-ring Bague-o	58 x 3	

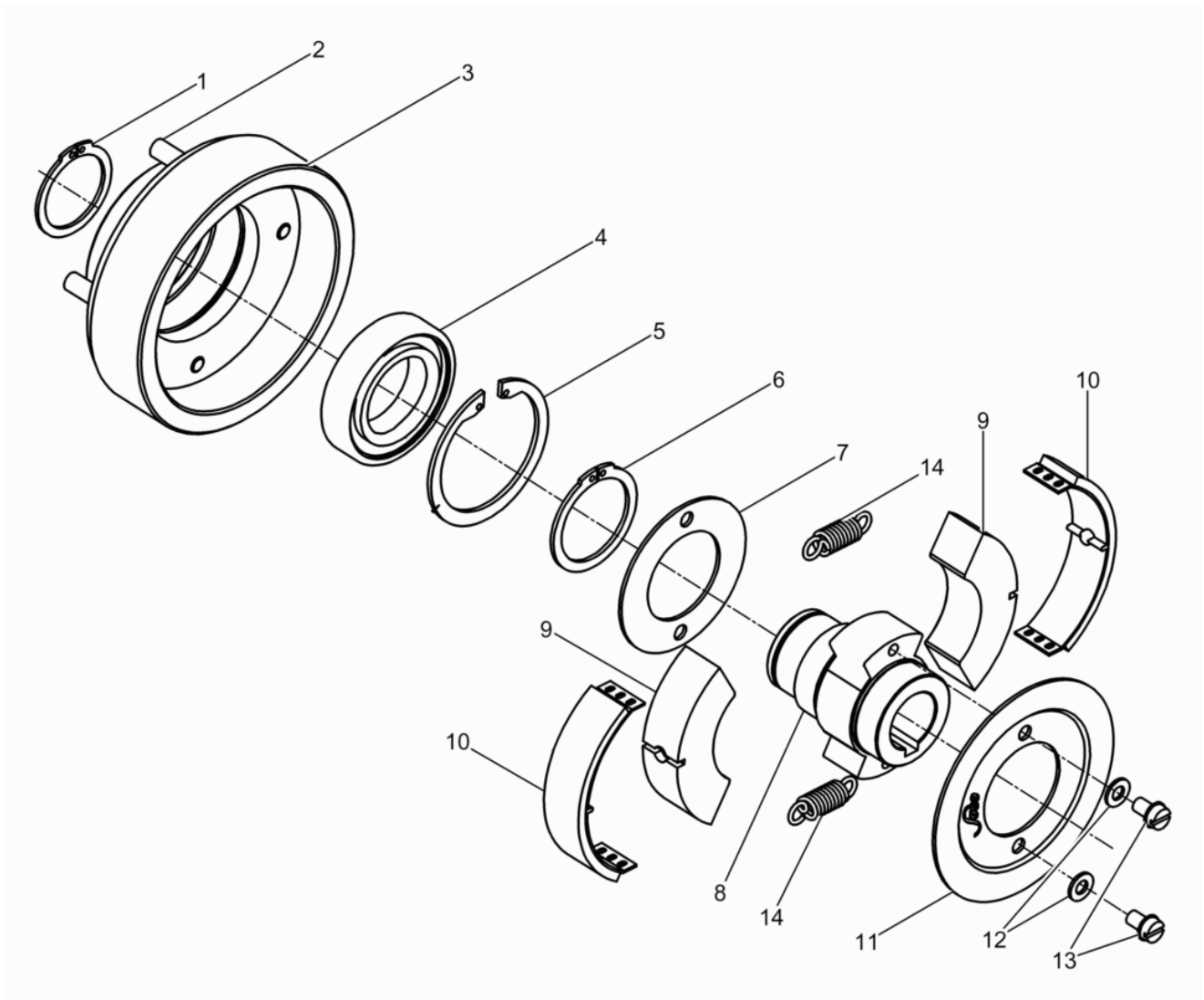

Pos. Item	Artikel Nr. Item no.	Pc.	Unit	Beschreibung Descripción	Description Description	Abm. Dim.	Norm Standard
						Drehmoment Torque	Schmierstoff Lubricant
1	5000216649	1	pc	Sicherungsring Anillo de retención	Retaining ring Bague d'arrêt		
2	5000216650	4	pc	Gewindestift Varilla roscada	Threaded pin Goupille fileté		
3	5000216651	1	pc	Glocke Campana	Alarm Cloche		
4	5000022625	1	pc	Rillenkugellager Rodamiento a bolas	Grooved ball bearing Roulement rainuré à billes		
5	5000216653	1	pc	Sicherungsring Anillo de retención	Retaining ring Bague d'arrêt		
6	5000201717	1	pc	Sicherungsring Anillo de retención	Retaining ring Bague d'arrêt	A40 x 1,75	
7	5000059740	1	pc	Fixierscheibe Arandela de retención	Fixing disc Rondelle de fixation		
8	5000216654	1	pc	Nabe Cubo	Hub Moyeu		
9	5000216655	2	pc	Fliehgewicht Peso centrífugo	Centrifugal weight Poids centrifuge		
10	5000048944	2	pc	Belagbügel Zapata	Lining Garniture d'embrayage		
11	5000125881	1	pc	Deckscheibe Arandela	Cover washer Rondelle de recouvrement		
12	5000201719	2	pc	Sicherungsscheibe Arandela de seguridad	Lock washer Rondelle d'arrêt	S6	
13	5000201718	2	pc	Zylinderschraube Tornillo cilíndrico	Cheese head screw Vis à tête cylindrique		
14	5000216656	2	pc	Feder Resorte	Spring Ressort		

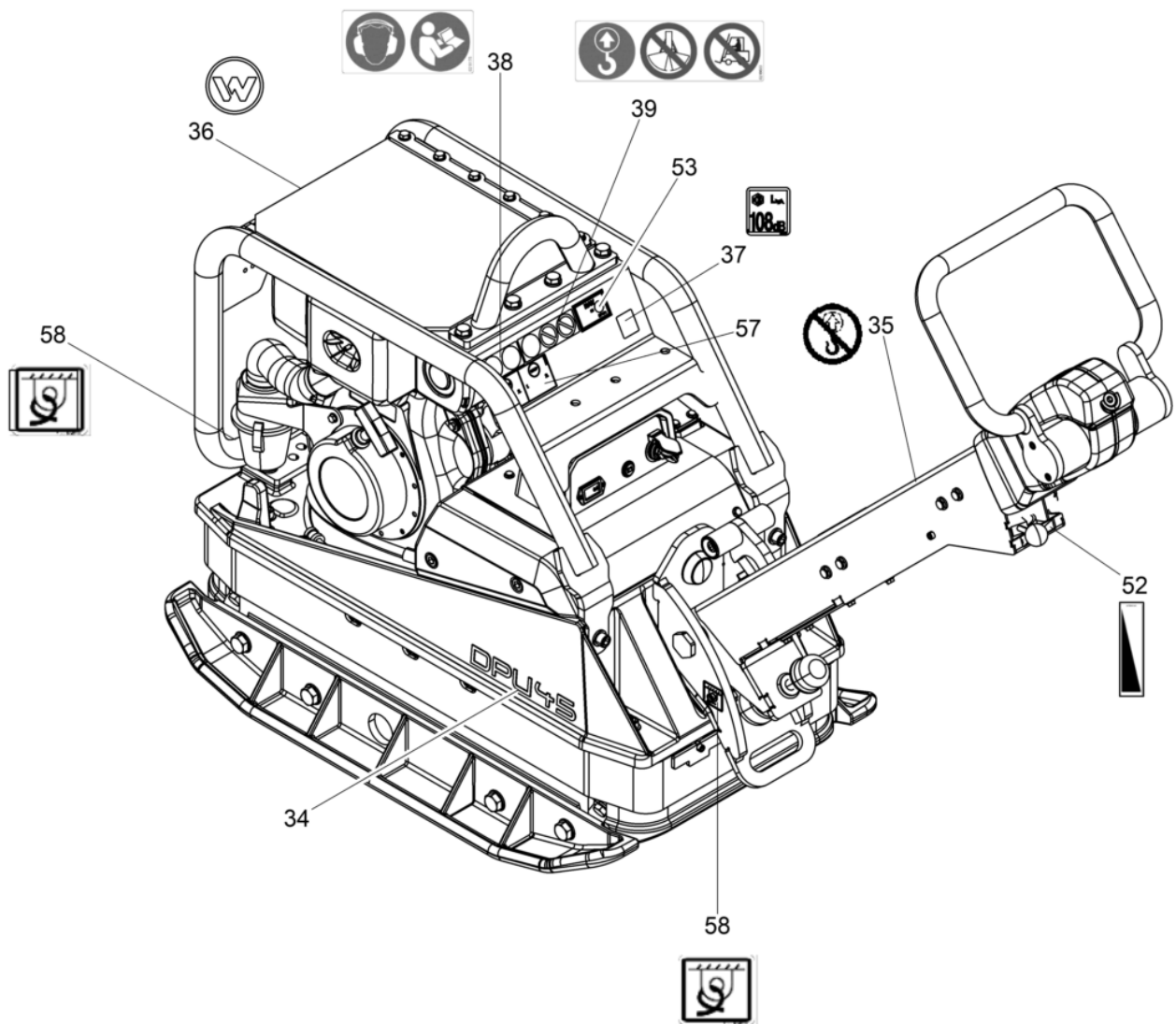



Pos. Item	Artikel Nr. Item no.	Pc.	Unit	Beschreibung Descripción	Description Description	Abm. Dim.	Norm Standard
						Drehmoment Torque	Schmierstoff Lubricant
34	5100068273	2	pc	Aufkleber-Typ Tipo etiqueta autoadhesiva	Type label Autocollant de type		
35	5000220000	1	pc	Aufkleber-Warnhinweis Calcomanía-indicación	Instruction label Autocollant avec indication		
36	5000222085	1	pc	Aufkleber Symbol Calcomanía símbolo	Label symbol Autocollant symbole		
37	5000129784	1	pc	Aufkleber-Schalleistungspegel Etiqueta autoadhesiva-nivel de potencia acúëstica	Decal-sound power level Autocollante-niveau sonore		
38	5000219175	1	pc	Aufkleber Calcomanías	Labels Autocollants		
39	5000216633	1	pc	Aufkleber-Hinweis Calcomanía-indicación	Instruction label Autocollant avec indication		
52	5000219259	1	pc	Aufkleber Calcomanías	Labels Autocollants		
53	5100011227	1	pc	Aufkleber HAV 24H Calcomanía hav 24h	Label hav 24h Autocollant hav 24h		
57	5100026807	1	pc	Aufkleber (Start Stop) Calcomanías (start stop)	Labels (start stop) Autocollants (start stop)		
58	1000184310	3	pc	Aufkleber Calcomanía	Label Autocollant		

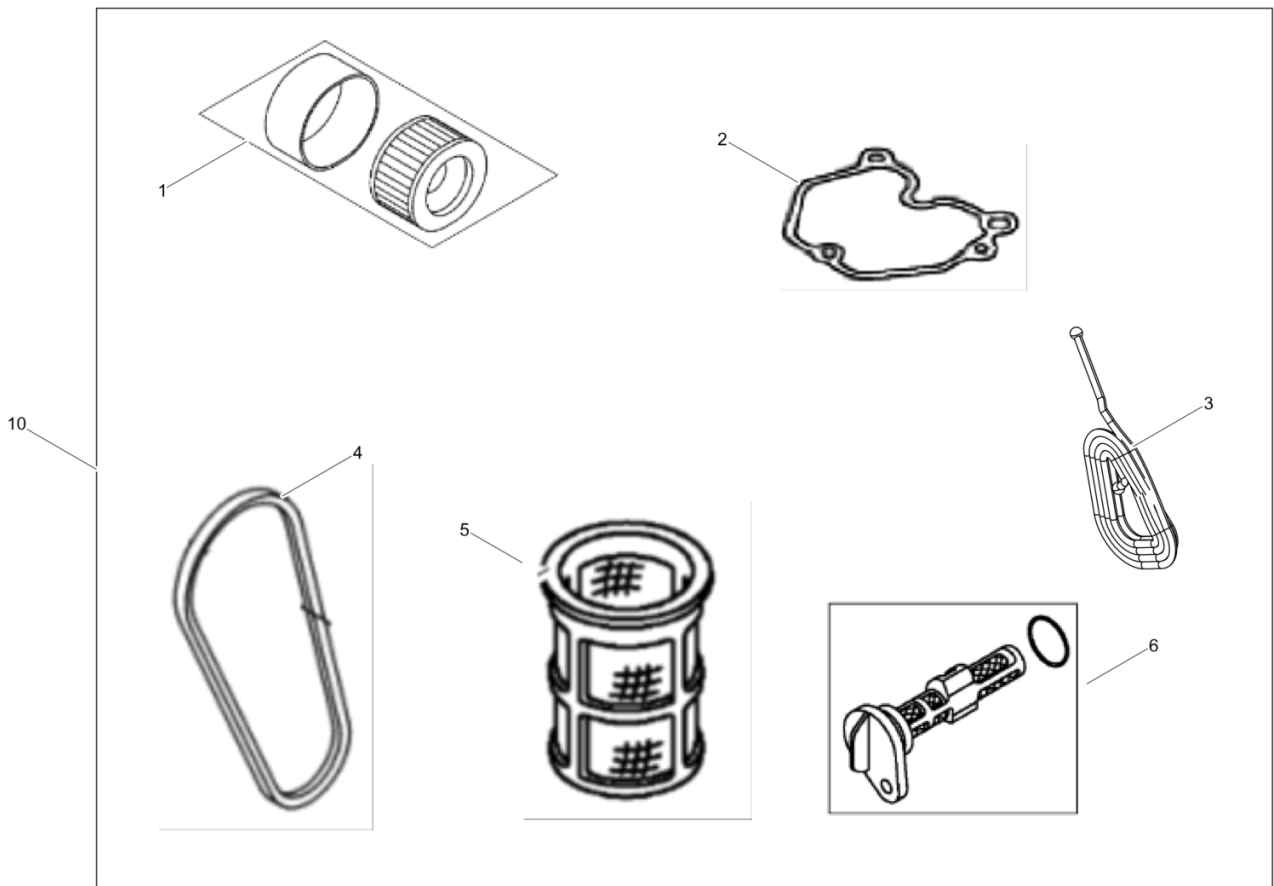

Pos. Item	Artikel Nr. Item no.	Pc.	Unit	Beschreibung Descripción	Description Description	Abm. Dim.	Norm Standard
						Drehmoment Torque	Schmierstoff Lubricant
1	5000217854	1	pc	Luffiltereinsatz Inserto para filtro de aire	Air filter insert Garniture filtre à air		
2	5000217846	1	pc	Dichtung Junta de estanqueidad	Gasket Garniture		
3	5000210554	1	pc	Starterseil Cuerda	Rope Corde		
4	5100052270	1	pc	Keilriemen Correa en v	V-belt Courroie		
5	5100059741	1	pc	Kraftstofffilter Filtro de combustible	Fuel filter Filtre à carburant		
6	5100059723	1	pc	Ölfilter Kpl. Filtro de aceite cpl.	Oil filter cpl. Filtre d'huile cpl.		
10	5100071766	1	pc	Wartungspaket Juego para mantenimiento	Maintenance kit Jeu d'entretien		

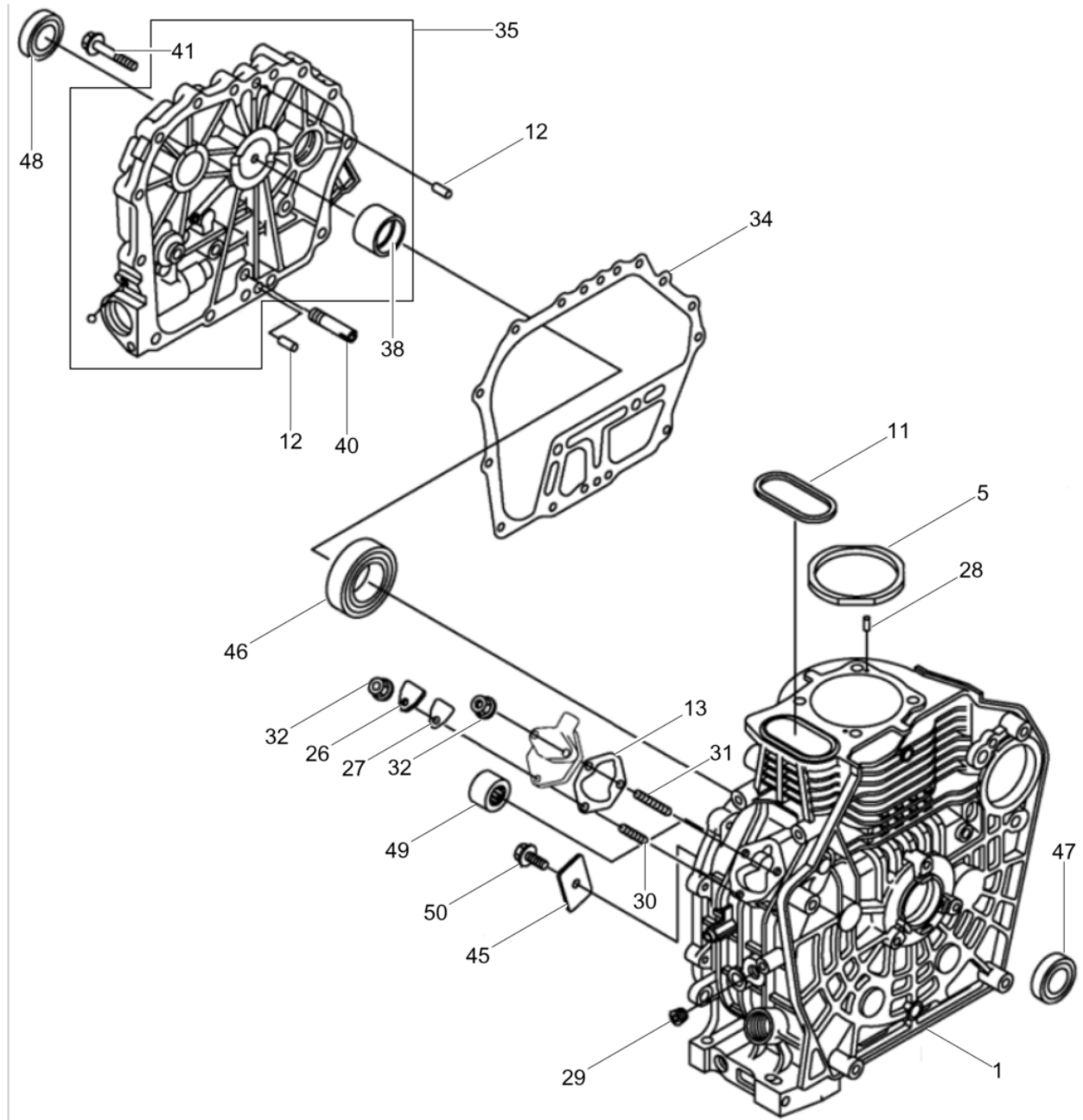

Pos. Item	Artikel Nr. Item no.	Pc.	Unit	Beschreibung Descripción	Description Description	Abm. Dim.	Norm Standard
						Drehmoment Torque	Schmierstoff Lubricant
1	5000217833	1	pc	Kurbelgehäuse Cárter	Crankcase Carter		
5	5100031962	1	pc	Kopfdichtung Junta de culata	Head gasket Joint de culasse		
11	5000210612	1	pc	O-Ring Anillo-o	O-ring Joint torique		
12	5000213226	2	pc	Stift Espiga	Pin Goupille		
13	5000210485	1	pc	Dichtung Junta	Gasket Joint		
26	5000210486	1	pc	Deckel Tapa	Cover Couvercle		
27	5000073612	1	pc	Dichtung Junta	Gasket Joint		
27	5000210614	1	pc	Dichtung Junta	Gasket Joint		
28	5000119715	2	pc	Stift Espiga	Pin Goupille	4x8	
29	5000217932	1	pc	Schraubverschluss Cierre roscada	Screw locking Fermeture de vissage		
30	5000119720	1	pc	Gewindebolzen Perno roscado	Threaded bolt Boulon fileté	M6 x 18	
31	5000119721	2	pc	Bolzen Perno	Bolt Boulon	M6 x 22	
32	5000119722	3	pc	Mutter Tuerca	Nut Ecrou	M6	
34	5000210613	1	pc	Kurbelwellendichtung Cigueñal junta	Crankshaft gasket Vilebrequin joint		
35	5100061528	1	pc	Kurbelgehäusedeckel Tapa del cárter	Crankcase cover Couvercle de carter		
38	5100061531	1	pc	Gleitlager Cojinete deslizante	Slide bearing Roulement de glissement		
38	5100061543	1	pc	Gleitlager 0,25 Cojinete deslizante 0,25	Slide bearing 0,25 Roulement de glissement 0,25		
38	5100061546	1	pc	Gleitlager 0,5 Cojinete deslizante 0,5	Slide bearing 0,5 Roulement de glissement 0,5		
40	5000210490	1	pc	Leitung Cable eléctrico	Electric wire Fil ressortant		
41	5000085522	15	pc	Schraube Tornillo	Screw Vis	M8 x 35 25Nm/18ft.lbs	
45	5000119726	1	pc	Halter Soporte	Bracket Support		
46	5000085532	1	pc	Kugellager Rodamiento a bolas	Ball bearing Roulement rainuré à billes		
47	5000119727	1	pc	Wellendichtring Empaque de aceite	Oil seal Joint d'huile		
48	5000119727	1	pc	Wellendichtring Empaque de aceite	Oil seal Joint d'huile		
49	5000217934	1	pc	Nadellager Cojinete de agujas	Needle bearing Roulement à aiguilles		
50	5000073622	1	pc	Schraube Tornillo	Screw Vis	M8 x 12 25Nm/18ft.lbs	

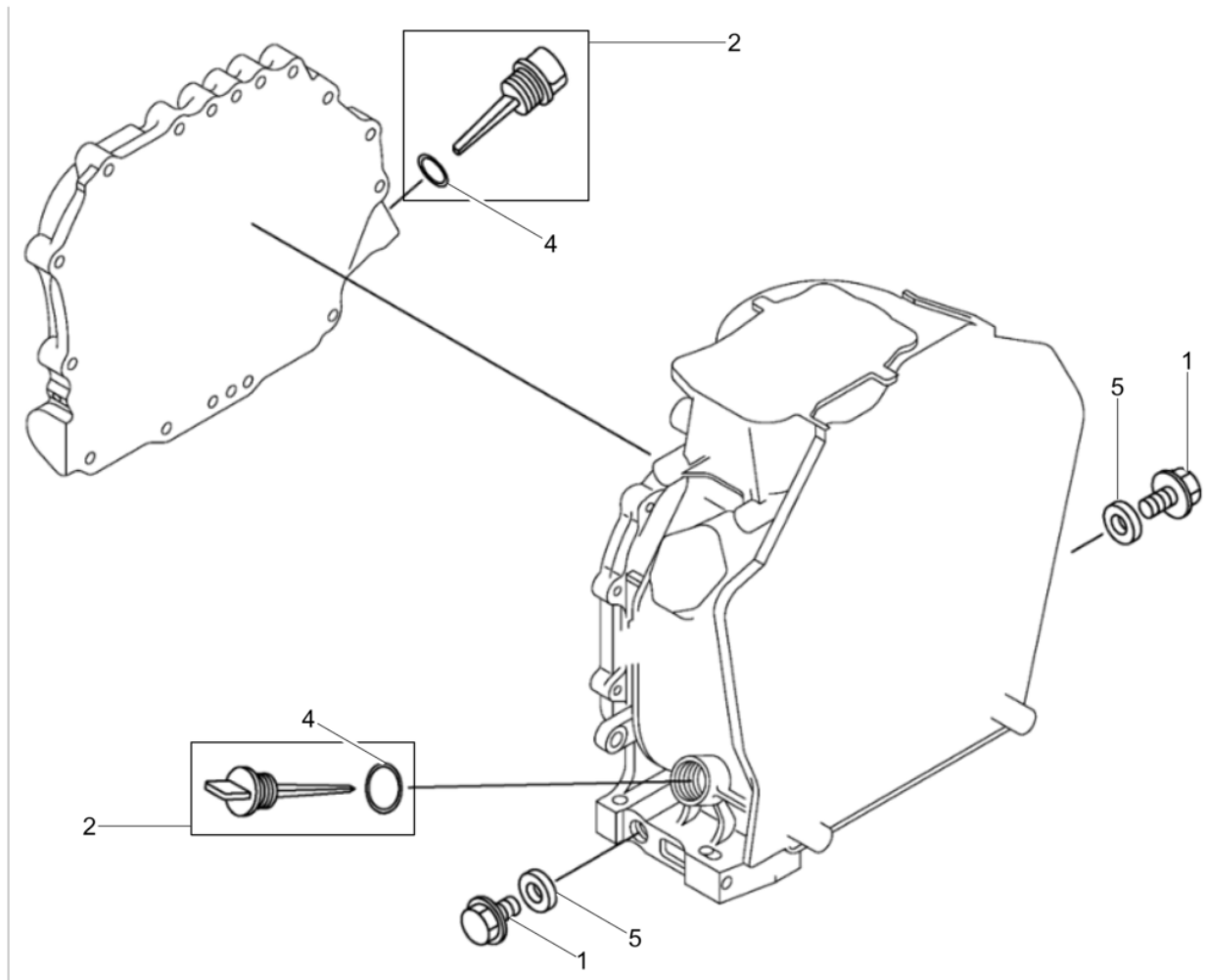

Pos. Item	Artikel Nr. Item no.	Pc.	Unit	Beschreibung Descripción	Description Description	Abm. Dim.	Norm Standard
						Drehmoment Torque	Schmierstoff Lubricant
1	5000213227	2	pc	Verschlusschraube Tapón roscado	Screw plug Vis de fermeture		
2	5000150327	2	pc	Ölmeßstab Kpl. Varilla de sondear aceite cpl.	Oil dip stick cpl. Jauge de niveau d'huile cpl.		
4	5100039305	2	pc	O-Ring Anillo-o	O-ring Bague-o		
5	5000073608	2	pc	Scheibe Arandela	Washer Rondelle		

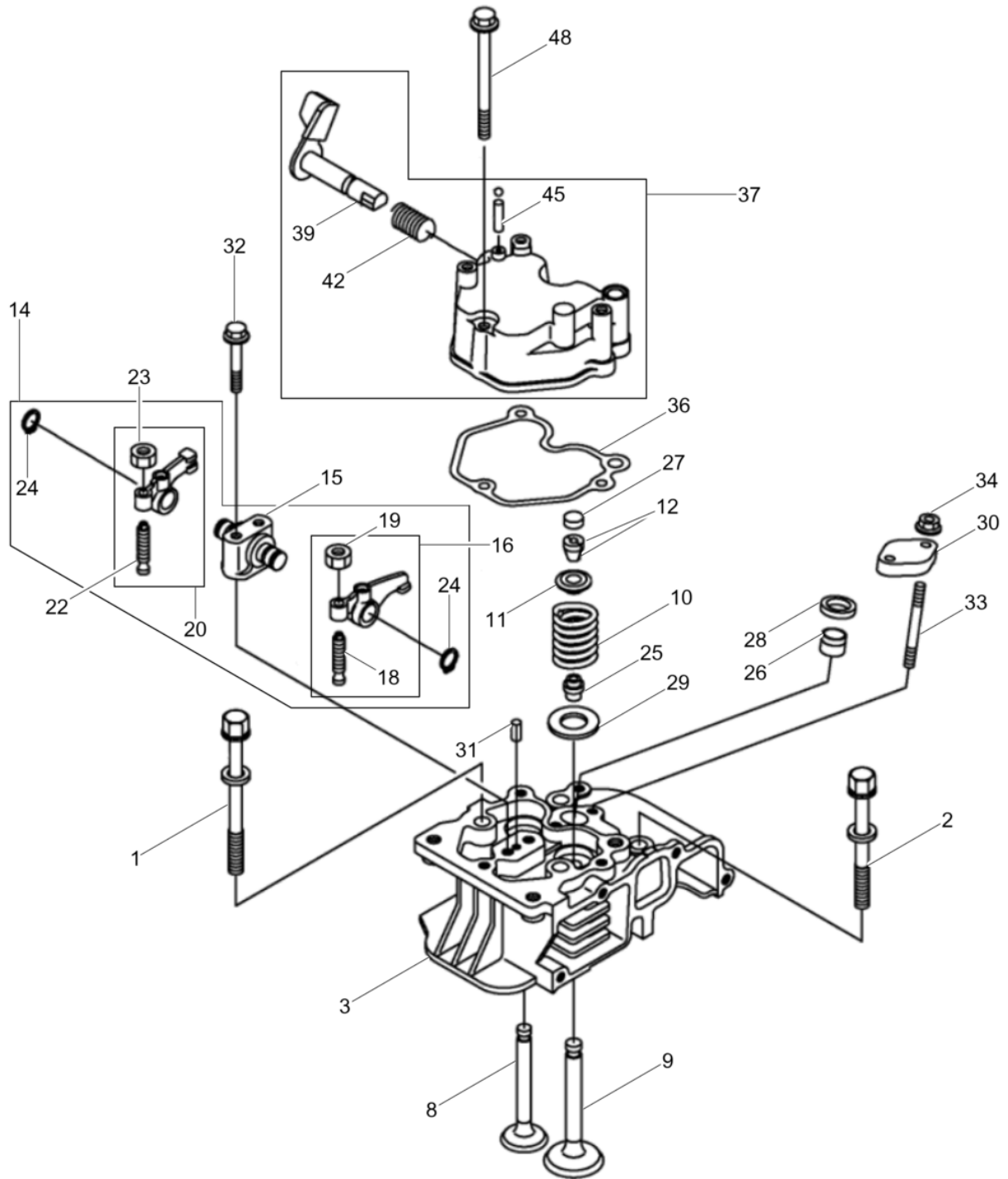



Pos. Item	Artikel Nr. Item no.	Pc.	Unit	Beschreibung Descripción	Description Description	Abm. Dim.	Norm Standard
						Drehmoment Torque	Schmierstoff Lubricant
1	5000217834	2	pc	Sechskantschraube Tornillo hexagonal	Hexagonal head cap screw Vis à tête hexagonale		
2	5000217835	2	pc	Sechskantschraube Tornillo hexagonal	Hexagonal head cap screw Vis à tête hexagonale		
3	5100061547	1	pc	Zylinderkopf Culata	Cylinder head Culasse		
8	5100000729	1	pc	Einlassventil Válvula de admisión	Intake valve Soupape dadmission		
9	5100000730	1	pc	Auslassventil Válvula de escape	Exhaust valve Soupape d'échappement		
10	5000217841	2	pc	Feder Resorte	Spring Ressort		
11	5000217842	2	pc	Federgehäuse Carcasa de resorte	Spring housing Logement du ressort		
12	5000217850	2	pc	Ventilkonussatz Soporte	Spring holder Support		
14	5100000731	1	pc	Kipphebel Kpl. Balancín cpl.	Rocker arm cpl. Culbuteur cpl.		
15	5100000732	1	pc	Hebelbock Asiento	Support Support		
16	5100000733	1	pc	Einlasskippebel Balancín de admisión	Inlet rocker arm Culbuteur		
18	5000096764	1	pc	Einstellschraube Regulador	Control Commande		
19	5000119736	1	pc	Sicherungsmutter Contratuerca	Locknut Contre-écrou		
20	5100000734	1	pc	Auslaßkippebel Balancín de escape	Exhaust rocker arm Culbuteur		
22	5000096764	1	pc	Einstellschraube Regulador	Control Commande		
23	5000119736	1	pc	Sicherungsmutter Contratuerca	Locknut Contre-écrou		
24	5000119737	2	pc	Klemme Abrazadera	Clamp Pince		
25	5100031963	2	pc	Dichtung Empaque	Seal Joint		
26	5000217896	1	pc	Dichtung Junta de estanqueidad	Gasket Garniture		
27	5000085537	2	pc	Ventilkappe Casquete de válvula	Valve cap Joint de soupape		
28	5100059780	1	pc	Ventilsitz Asiento de válvula	Valve seat Siège de clapet		
29	5000213231	2	pc	Scheibe Disco	Washer Rondelle		
30	5000217849	1	pc	Halter Soporte	Bracket Équerre		
31	5000073641	1	pc	Stift Espiga	Pin Goupille	4x 8	
32	5000217935	2	pc	Schraube Tornillo	Screw Vis		
33	5000073630	2	pc	Gewindebolzen Perno prisionero	Stud Boulon	M 6x 55	
34	5000119722	2	pc	Mutter Tuerca	Nut Ecrou	M6	
36	5000217846	1	pc	Dichtung Junta de estanqueidad	Gasket Garniture		

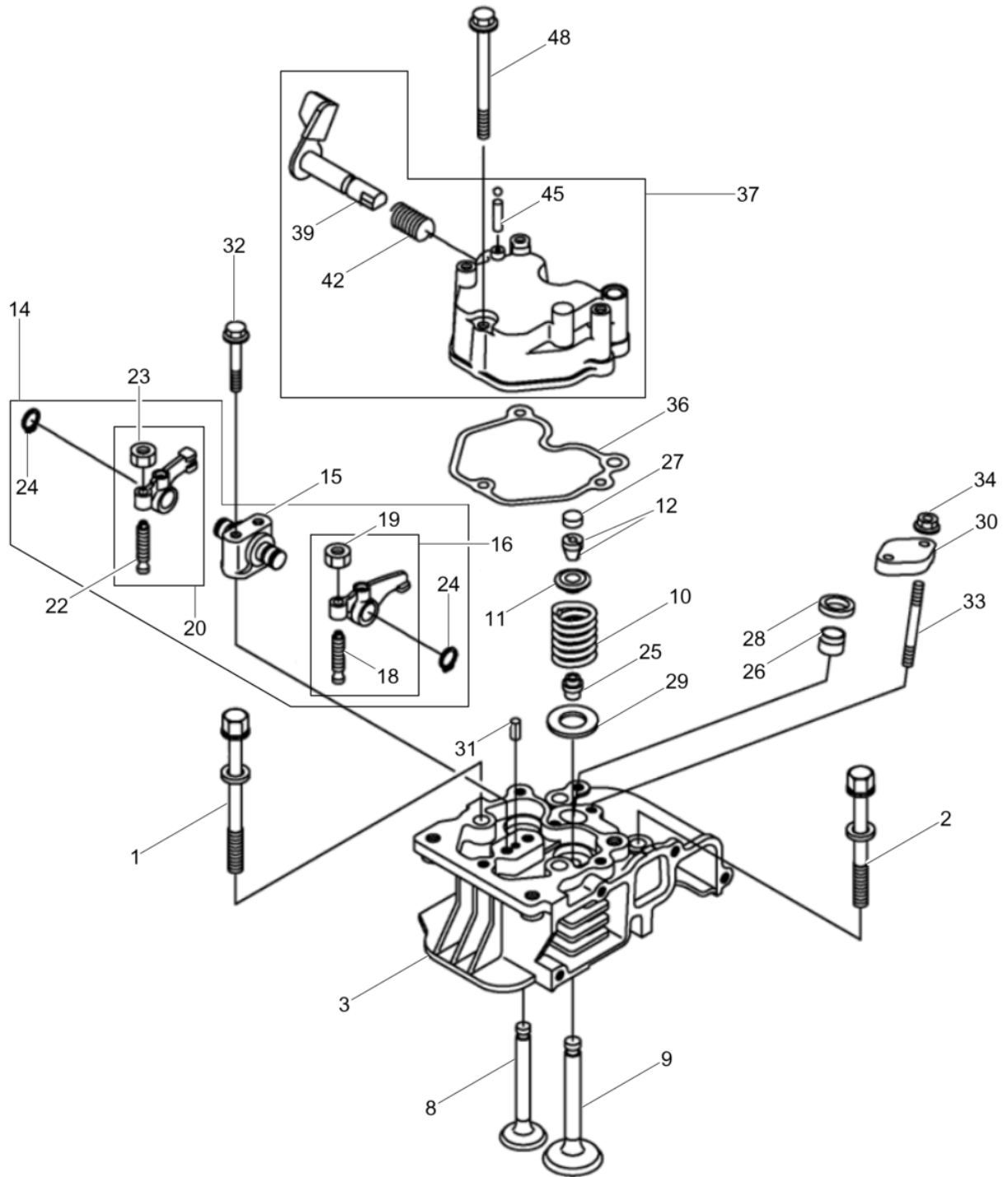

Pos. Item	Artikel Nr. Item no.	Pc.	Unit	Beschreibung Descripción	Description Description	Abm. Dim.	Norm Standard
						Drehmoment Torque	Schmierstoff Lubricant
37	5000217851	1	pc	Zylinderkopfdeckel Tapa	Cover Couvercle		
39	5000217837	1	pc	Welle Kpl. Árbol cpl.	Shaft cpl. Arbre cpl.		
42	5000217898	1	pc	Feder Resorte	Spring Ressort		
45	5000073648	1	pc	Stift Espiga	Pin Goupille	3x16	
48	5100039148	3	pc	Flanschschraube Tornillo de brida	Flange screw Vis de bride		

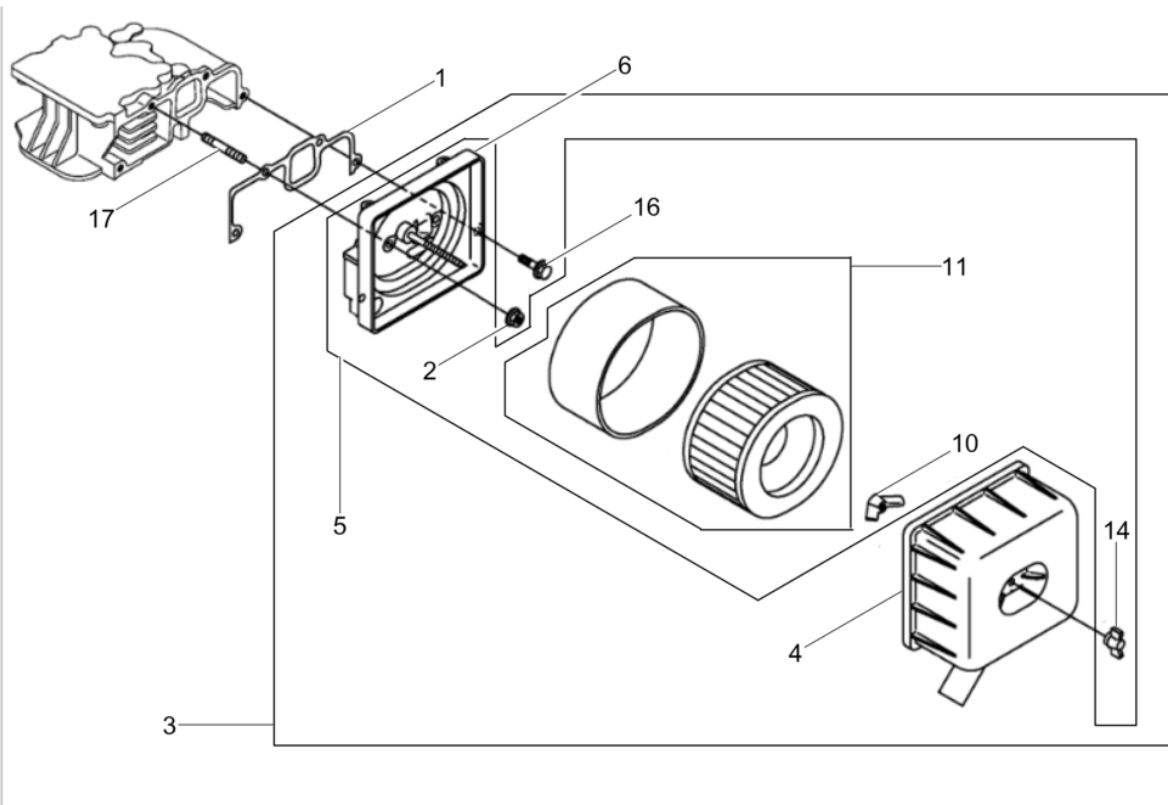

Pos. Item	Artikel Nr. Item no.	Pc.	Unit	Beschreibung Descripción	Description Description	Abm. Dim.	Norm Standard
						Drehmoment Torque	Schmierstoff Lubricant
1	5000217852	1	pc	Luftfilterdichtung Junta filtro de aire	Air filter seal Joint filtre à air		
2	5000213232	3	pc	Flanschmutter Tuerca de brida	Flange nut Écrou à bride		
3	5000217886	1	pc	Luftfilter Kpl. Filtro de aire cpl.	Air filter cpl. Filtre à air cpl.		
4	5000217892	1	pc	Luftfilterdeckel Tapa-filtro del aire	Air cleaner cover Couvercle-filtre à air		
5	5000217887	1	pc	Luftfiltergehäuse Kpl. Carcasa filtro de aire cpl.	Air filter housing cpl. Carter de filtre cpl.		
6	5100061548	1	pc	Konsole Consola	Console Console		
10	5000217853	1	pc	Flügelmutter Tuerca mariposa	Wing nut Ecrou papillon		
11	5000217854	1	pc	Luftfiltereinsatz Inserto para filtro de aire	Air filter insert Garniture filtre à air		
14	5000217855	1	pc	Flügelmutter Tuerca mariposa	Wing nut Ecrou papillon		
16	5000150361	1	pc	Flanschschraube Tornillo de brida	Flange screw Vis de bride	M6 x 20	
17	5000217936	3	pc	Gewindebolzen Perno roscado	Threaded bolt Boulon fileté	M6x30	

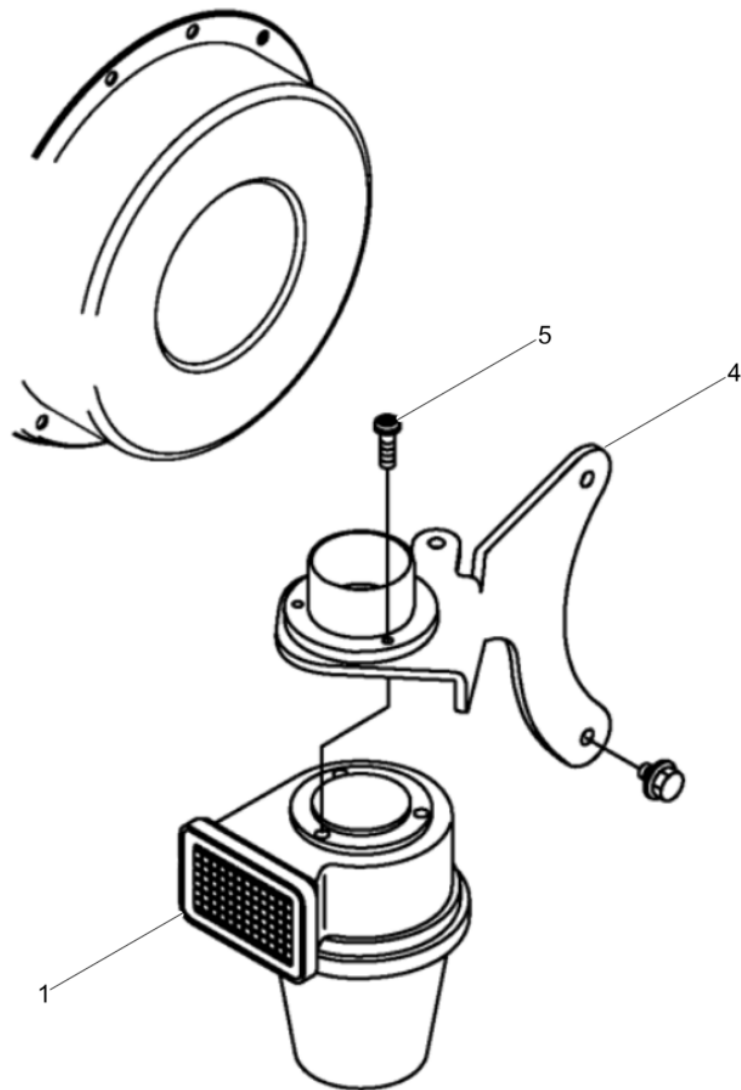

Pos. Item	Artikel Nr. Item no.	Pc.	Unit	Beschreibung Descripción	Description Description	Abm. Dim.	Norm Standard
						Drehmoment Torque	Schmierstoff Lubricant
1	5000217893	1	pc	Vorabscheider Kpl. Prefiltro cpl.	Prefilter cpl. Prefiltre cpl.		
4	5000217894	1	pc	Halterung Soporte	Bracket Équerre		
5	5100000766	3	pc	Schraube Tornillo	Screw Vis	M5x16	

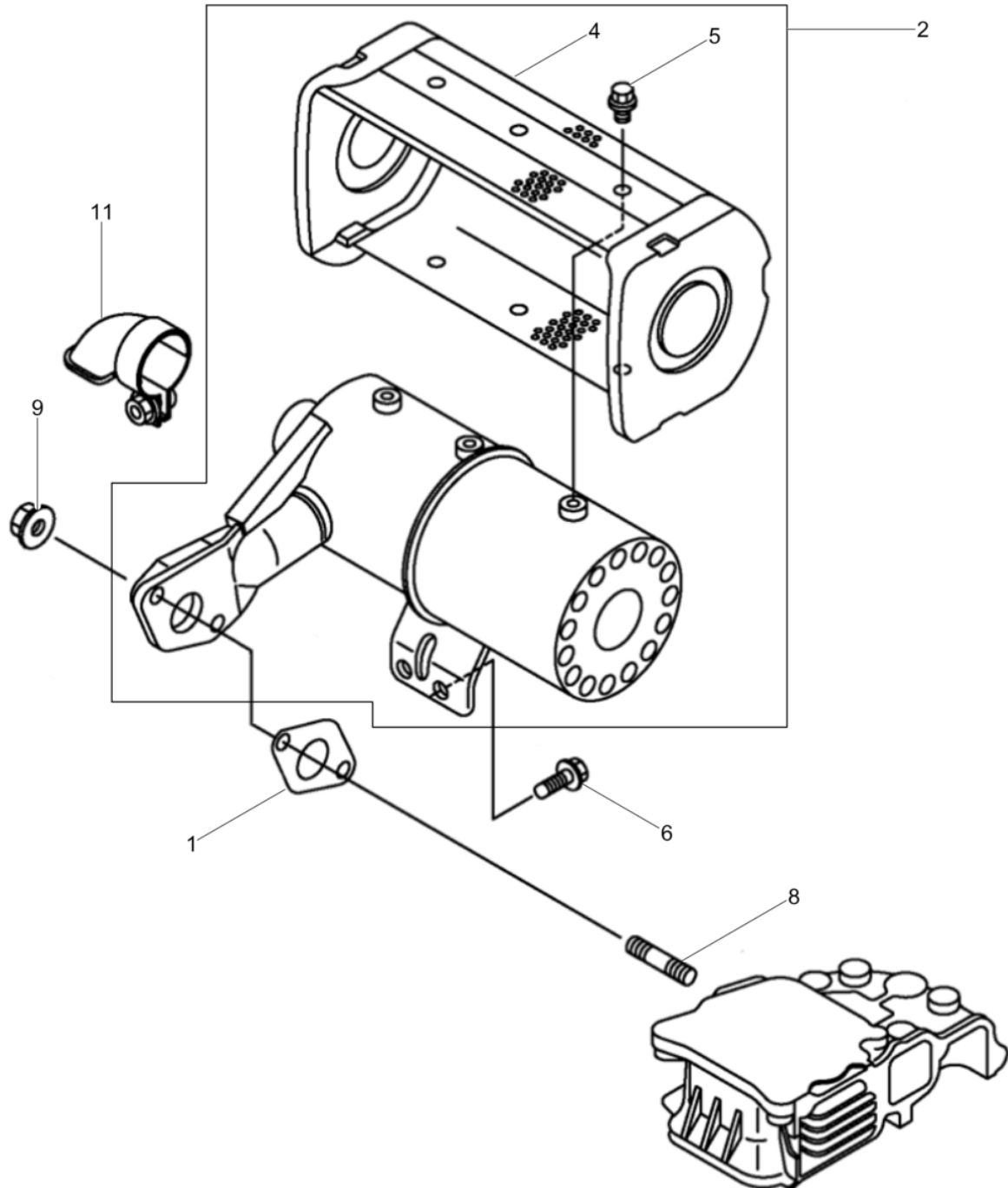



Pos. Item	Artikel Nr. Item no.	Pc.	Unit	Beschreibung Descripción	Description Description	Abm. Dim.	Norm Standard
						Drehmoment Torque	Schmierstoff Lubricant
1	5000210617	1	pc	Dichtung Junta	Gasket Joint		
2	5100061549	1	pc	Auspuff Kpl. Escape cpl.	Muffler cpl. Échappement cpl.		
4	5000073663	1	pc	Deckel Tapa	Cover Couvercle		
5	5000119905	6	pc	Schloßschraube Tornillo	Mushroom head bolt Vis	M 6x 8	
6	5000210533	2	pc	Sechskantschraube Tornillo hexagonal	Hexagonal head cap screw Vis à tête hexagonale	M6 x 14	
8	5000073640	2	pc	Gewindebolzen Perno prisionero	Stud Boulon	M 8x 18	
9	5000153995	2	pc	Mutter Tuerca	Nut Ecrou		
11	5000210502	1	pc	Auspuffdeflektor Deflector de escape	Exhaustdeflector Échappement déflecteur		

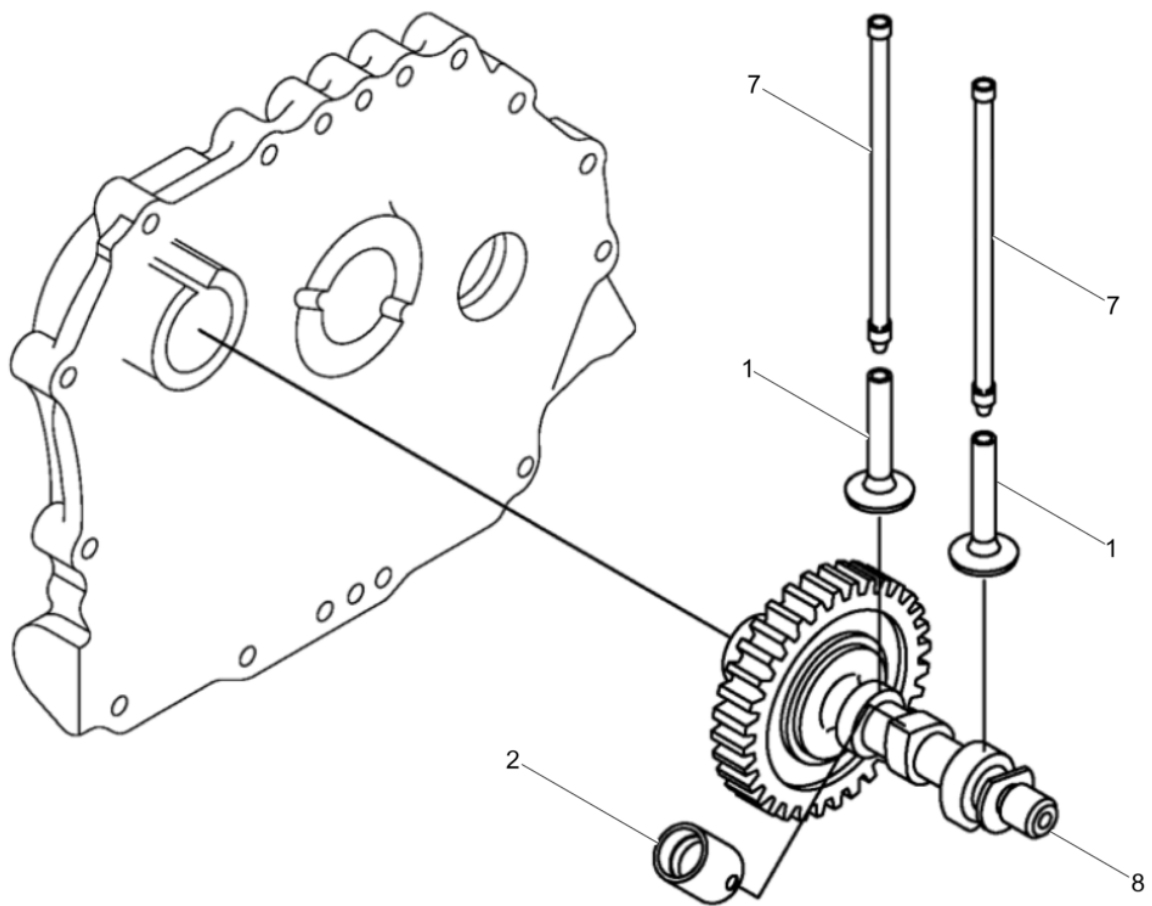

Pos. Item	Artikel Nr. Item no.	Pc.	Unit	Beschreibung Descripción	Description Description	Abm. Dim.	Norm Standard
						Drehmoment Torque	Schmierstoff Lubricant
1	5000217856	2	pc	Ventilstößel Levanta válvulas	Valve tappet Soupape de poussoir		
2	5000217857	1	pc	Stößel Alzaválvulas	Tappet Poussoir		
7	5000217858	2	pc	Stößelstange Empuje rod de la válvula	Valve push rod Tige pousseur de valve		
8	5100061551	1	pc	Nockenwelle Kpl. Árbol de levas cpl.	Camshaft cpl. Arbre à cames cpl.		

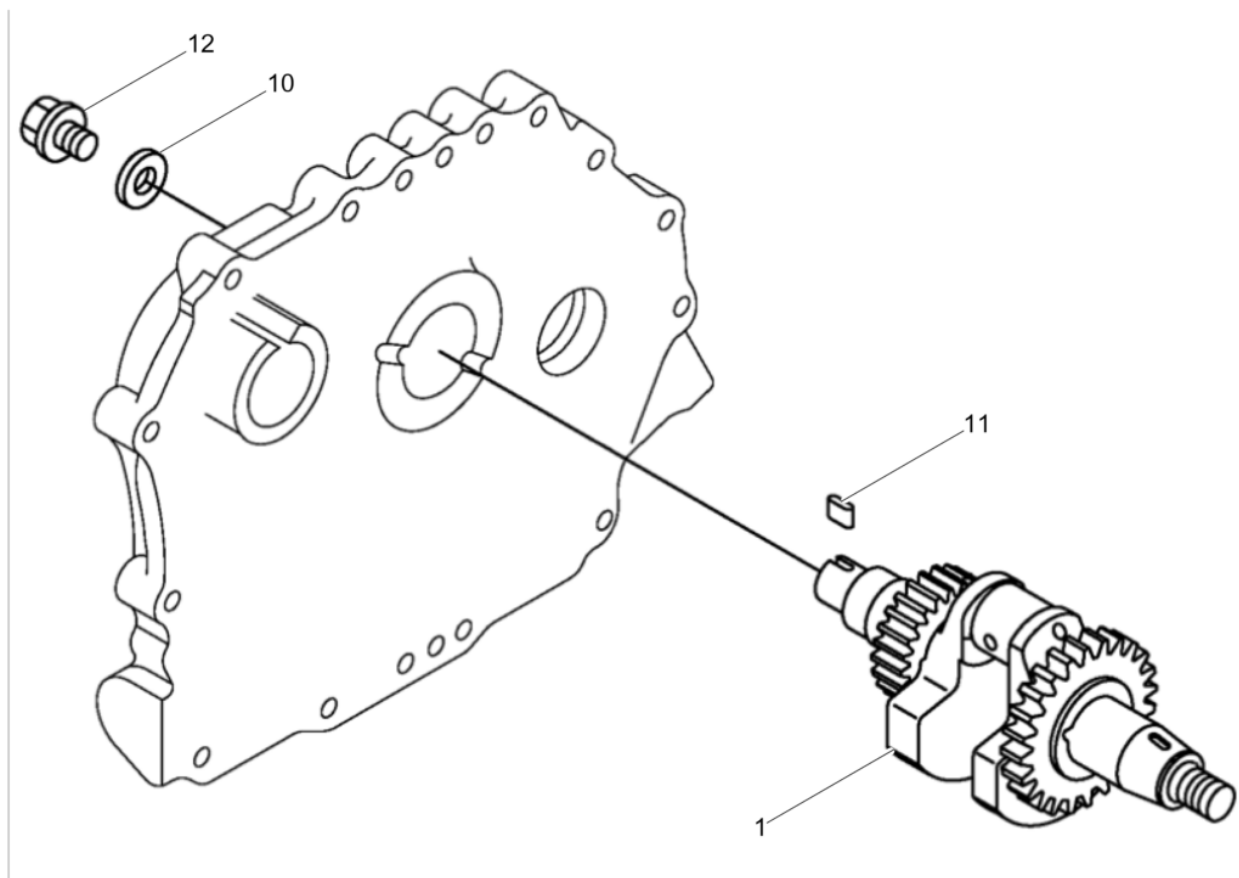

Pos. Item	Artikel Nr. Item no.	Pc.	Unit	Beschreibung Descripción	Description Description	Abm. Dim.	Norm Standard
						Drehmoment Torque	Schmierstoff Lubricant
1	5100061552	1	pc	Kurbelwelle Kpl. Cigüeñal cpl.	Crankshaft cpl. Vilebrequin cpl.		
10	5000073674	1	pc	Scheibe Arandela	Washer Rondelle		
11	5000210518	1	pc	Passfeder Chaveta	Fitting key Clavette	7 x 36	
12	5200019993	1	pc	Bolzen Perno	Bolt Boulon	M8 x 20	

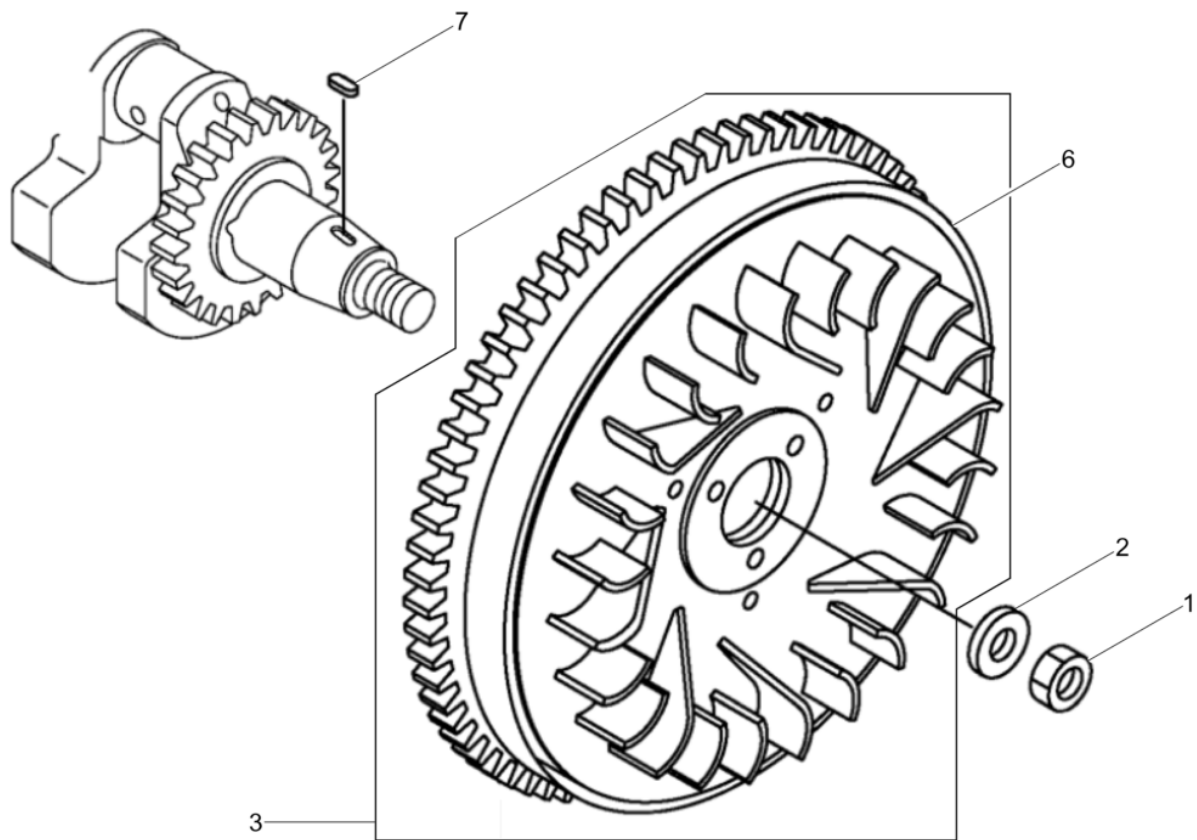

Pos. Item	Artikel Nr. Item no.	Pc.	Unit	Beschreibung Descripción	Description Description	Abm. Dim.	Norm Standard
						Drehmoment Torque	Schmierstoff Lubricant
1	5000210505	1	pc	Sechskantmutter Tuerca hexagonal	Hexagon nut Écrou hexagonal		
2	5000210508	1	pc	Scheibe Arandela	Washer Rondelle		
3	5000210506	1	pc	Schwungrad Volante	Flywheel Volant		
6	5000217918	1	pc	Zahnrad Engranaje	Gear Engrenage		
7	5000073670	1	pc	Schlüssel Llave	Wrench Clef	4 x 4 x 12	

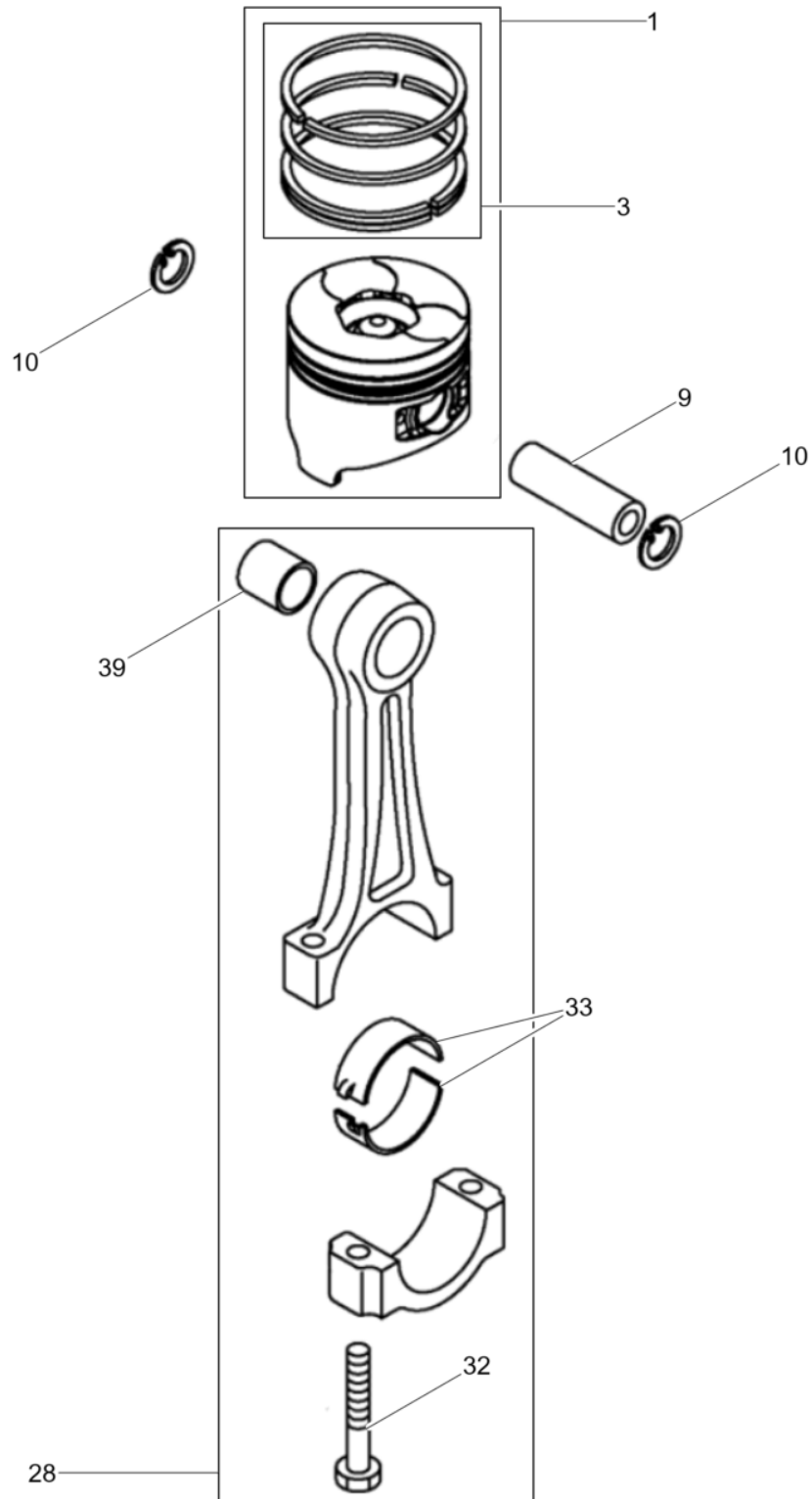



Pos. Item	Artikel Nr. Item no.	Pc.	Unit	Beschreibung Descripción	Description Description	Abm. Dim.	Norm Standard
						Drehmoment Torque	Schmierstoff Lubricant
1	5100061539	1	pc	Kolben Kpl. Pistón cpl.	Piston cpl. Piston cpl.		
1	5100061550	1	pc	Kolben Kpl. 0,25 Pistón cpl. 0,25	Piston cpl. 0,25 Piston cpl. 0,25		
1	5100061554	1	pc	Kolben Kpl. 0,5 Pistón cpl. 0,5	Piston cpl. 0,5 Piston cpl. 0,5		
3	5000210510	1	pc	Kolbendichtung Junta de pistón	Piston packing Ensemble piston		
3	5100061553	1	pc	Kolbenringsatz 0,25 Juego de aros de pistón 0,25	Set of piston rings 0,25 Jeu de segments de piston 0,25		
3	5100061555	1	pc	Kolbenringsatz 0,5 Juego de aros de pistón 0,5	Set of piston rings 0,5 Jeu de segments de piston 0,5		
9	5000150339	1	pc	Kolbenbolzen Perno de pistón	Piston pin Axe de piston		
10	5000085550	2	pc	Sprengring Anillo de retención	Snap ring Circlip		
28	5100061556	1	pc	Pleuel Kpl. Biela cpl.	Connecting rod cpl. Bielle cpl.		
32	5000150340	2	pc	Sechskantschraube Tornillo hexagonal	Hexagonal head cap screw Vis à tête hexagonale		
33	5100061529	1	pc	Lagerschale 0,5 Rodamiento 0,5	Bearing 0,5 Roulement 0,5		
33	5100061557	1	pc	Lagerschale Rodamiento	Bearing Roulement		
33	5100061558	1	pc	Lagerschale 0,25 Rodamiento 0,25	Bearing 0,25 Roulement 0,25		
39	5100060807	1	pc	Gleitlagerbuchse Casquillo	Bushing-piston pin Douille		

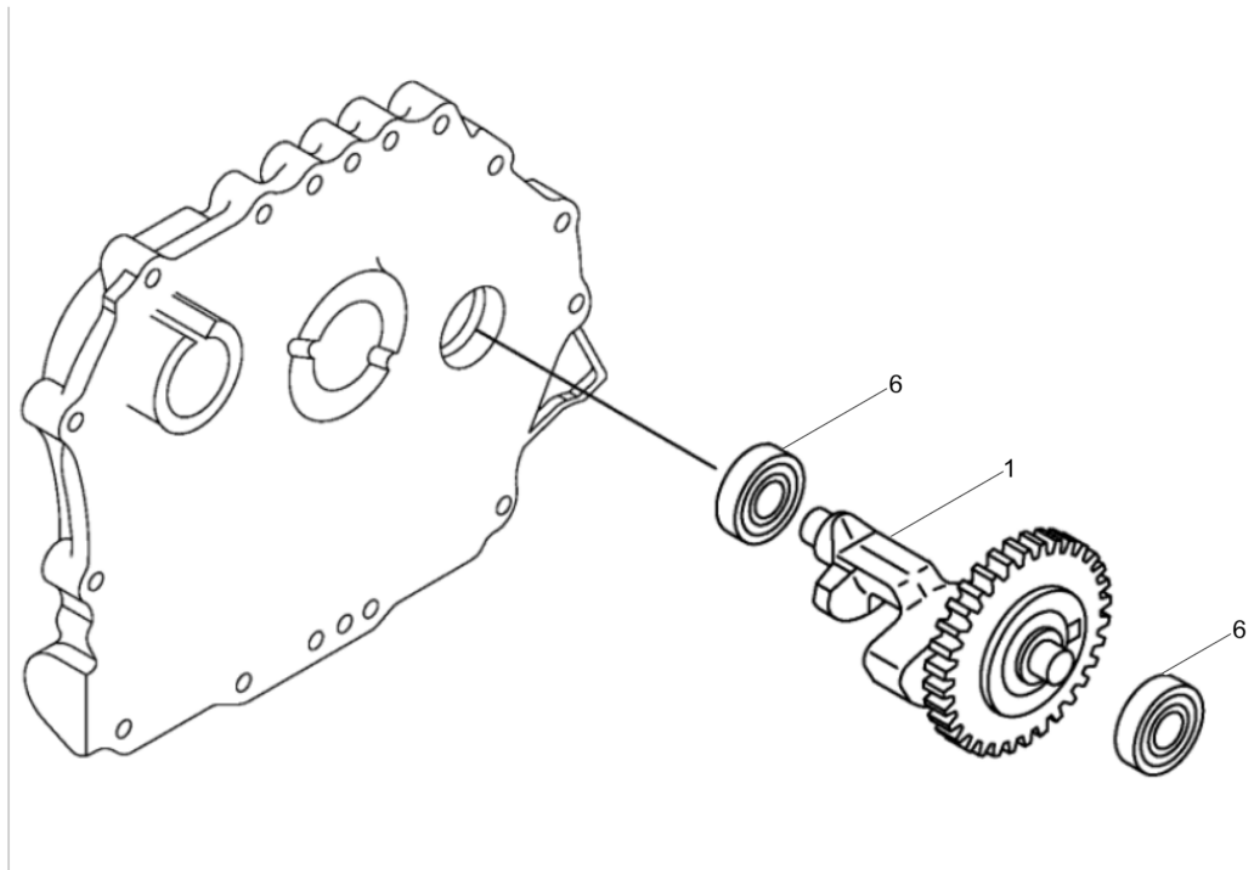

Pos. Item	Artikel Nr. Item no.	Pc.	Unit	Beschreibung Descripción	Description Description	Abm. Dim.	Norm Standard
						Drehmoment Torque	Schmierstoff Lubricant
1	5000217940	1	pc	Ausgleichswelle Arbol	Shaft Arbre		
6	5100061530	2	pc	Rillenkugellager Rodamiento a bolas	Grooved ball bearing Roulement rainuré à billes		

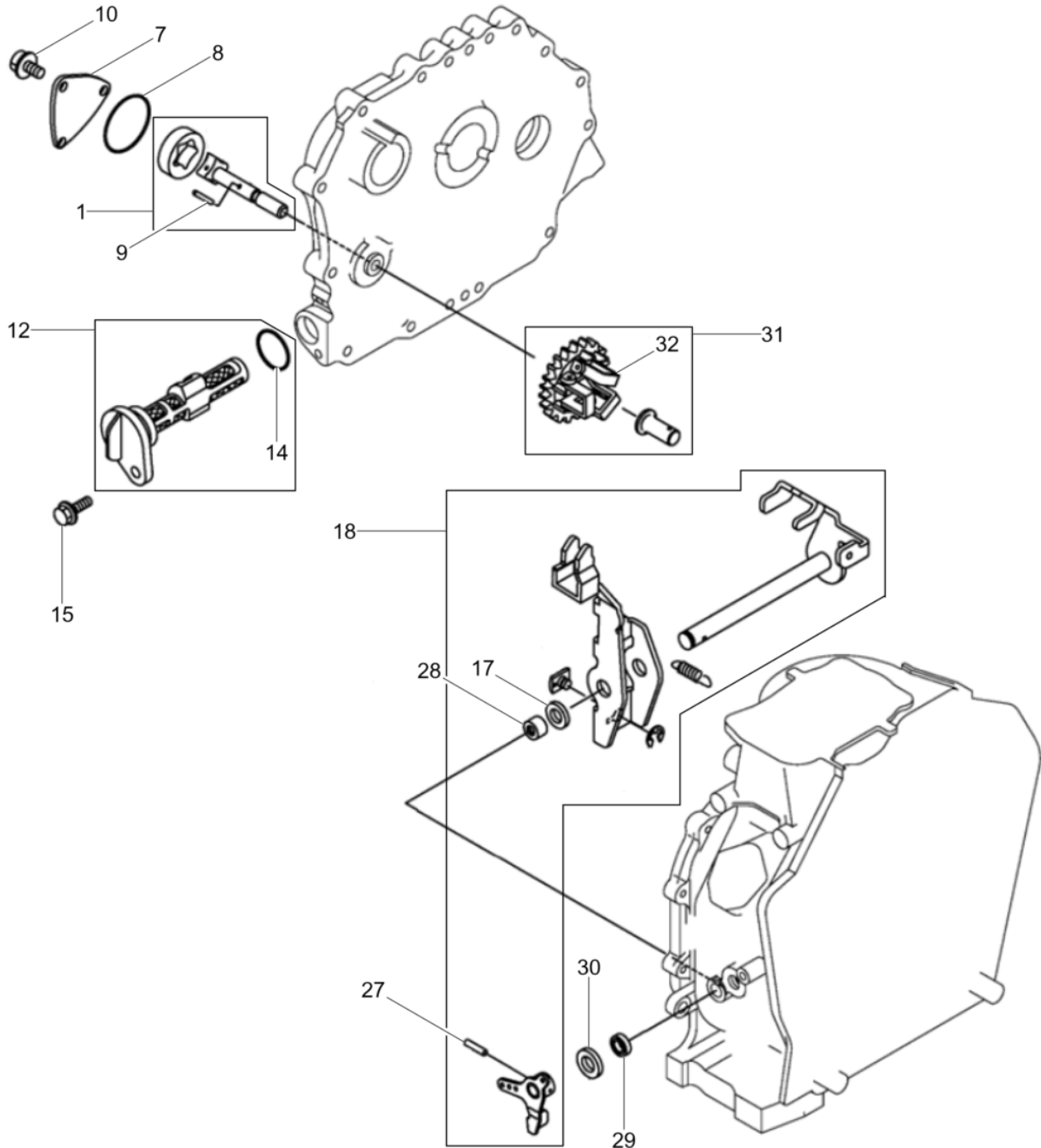

Pos. Item	Artikel Nr. Item no.	Pc.	Unit	Beschreibung Descripción	Description Description	Abm. Dim.	Norm Standard
						Drehmoment Torque	Schmierstoff Lubricant
1	5000073698	1	pc	Ölpumpe Bomba de aceite	Oil pump Pompe à huile		
7	5000210520	1	pc	Deckel Tapa	Cover Couvercle		
8	5000210618	1	pc	O-Ring Anillo-o	O-ring Joint torique		
9	5000073648	1	pc	Stift Espiga	Pin Goupille	3x16	
10	5000119897	3	pc	Schraube Tornillo	Screw Vis		
12	5100059723	1	pc	Ölfilter Kpl. Filtro de aceite cpl.	Oil filter cpl. Filtre d'huile cpl.		
14	5000073693	1	pc	O-Ring Anillo-o	O-ring Joint torique	22,4 x 1,8	
15	5000073659	1	pc	Schraube Tornillo	Screw Vis	M6 x 16 10Nm/7ft.lbs	
17	5000210527	1	pc	Dichtung Junta	Gasket Joint		
18	5100061532	1	pc	Regler Kpl. Regulador cpl.	Governor cpl. Régulateur cpl.		
27	5000119854	1	pc	Stift Espiga	Pin Goupille	3x20	
28	5000119867	2	pc	Lager Rodamiento	Bearing Roulement		
29	5000210526	1	pc	Öldichtung Junta de aceite	Oil seal Joint d'huile		
30	5000087375	1	pc	Scheibe Arandela	Washer Rondelle		
31	5000217943	1	pc	Drehzahlregler Kpl. Controlador de velocidad cpl.	Speed control module cpl. Régulateur de vitesse cpl.		
32	5000217882	1	pc	Reglergewicht Peso	Weight Poids		

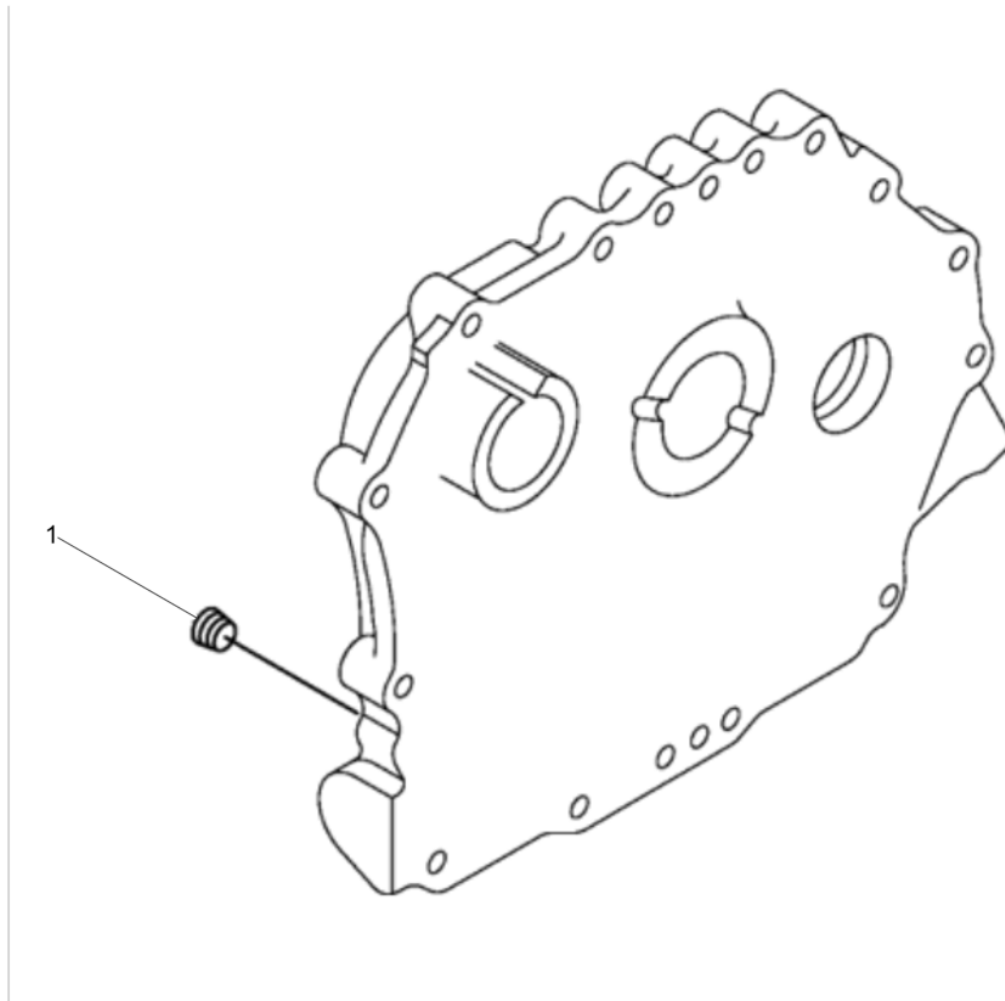

Pos. Item	Artikel Nr. Item no.	Pc.	Unit	Beschreibung Descripción	Description Description	Abm. Dim.	Norm Standard
						Drehmoment Torque	Schmierstoff Lubricant
1	5000119728	1	pc	Schraubverschluss Cierre roscada	Screw locking Fermeture de vissage		

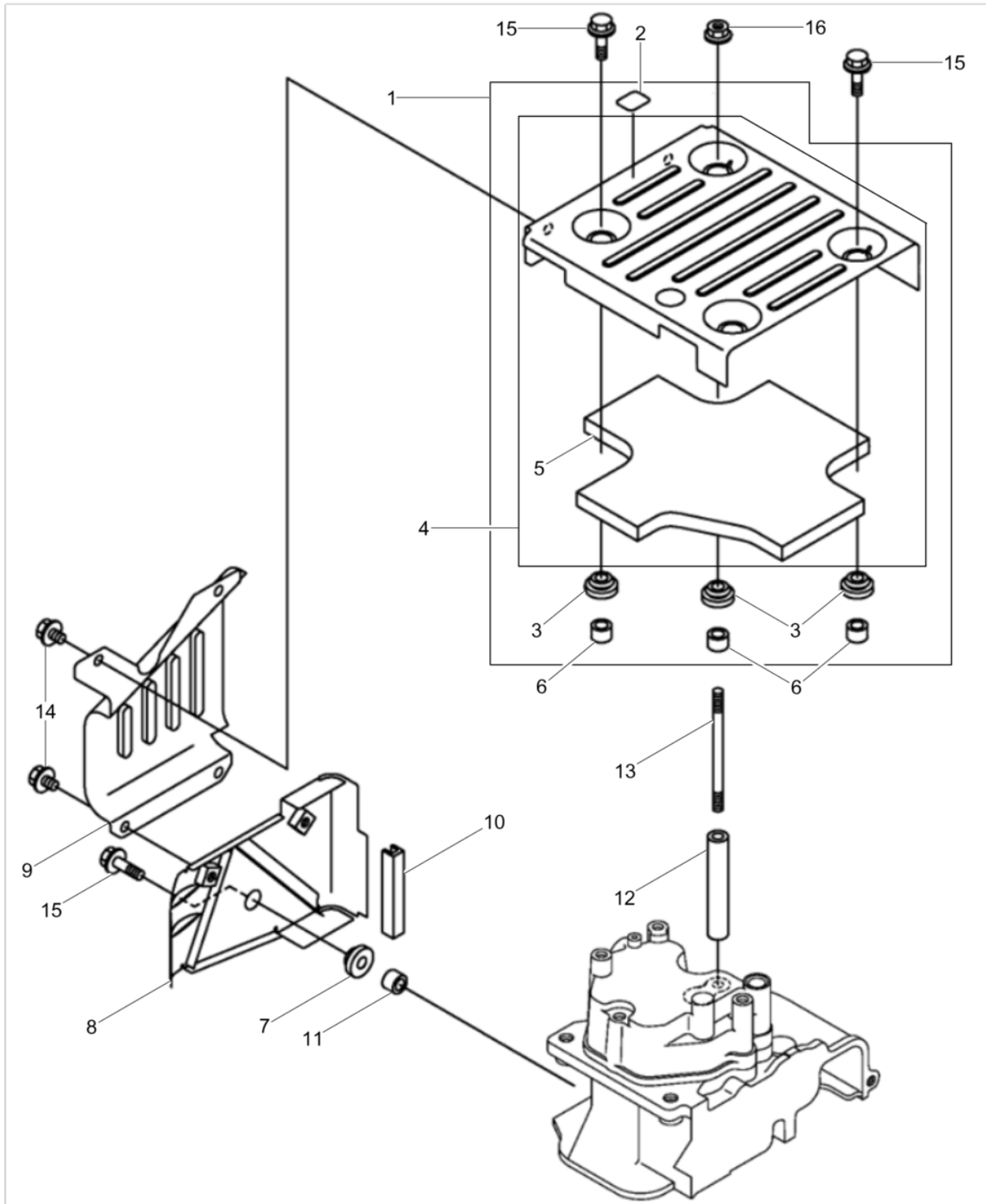



Pos. Item	Artikel Nr. Item no.	Pc.	Unit	Beschreibung Descripción	Description Description	Abm. Dim.	Norm Standard
						Drehmoment Torque	Schmierstoff Lubricant
1	5100061533	1	pc	Deckel Kpl. Tapa cpl.	Cover cpl. Couvercle cpl.		
2	5100000743	1	pc	Aufkleber Calcomanía	Label Autocollant		
3	5000217901	4	pc	Tülle Ojal	Grommet Passe-fil		
4	5100061534	1	pc	Deckel Tapa	Cover Couvercle		
5	5000217866	1	pc	Dämmatte Espuma silenciadora	Silencing foam Mousse insonorisante		
6	5000210540	4	pc	Hülse Collar	Sleeve Douille		
7	5000217901	1	pc	Tülle Ojal	Grommet Passe-fil		
8	5000217863	1	pc	Deckel Cubierta	Cover Couvercle		
9	5100000737	1	pc	Abdeckung Cobertura	Covering Couvercle		
10	5000217920	1	pc	Dichtung Junta de estanqueidad	Gasket Garniture		
11	5000210540	1	pc	Hülse Collar	Sleeve Douille		
12	5000217867	1	pc	Distanzstück Pieza distanciadora	Spacer Pièce d'écartement		
13	5000217868	1	pc	Gewindebolzen Perno prisionero	Stud Boulon		
14	5000119905	4	pc	Schloßschraube Tornillo	Mushroom head bolt Vis	M 6x 8	
15	5000150361	4	pc	Flanschschraube Tornillo de brida	Flange screw Vis de bride	M6 x 20	
16	5000119722	1	pc	Mutter Tuerca	Nut Ecrou	M6	

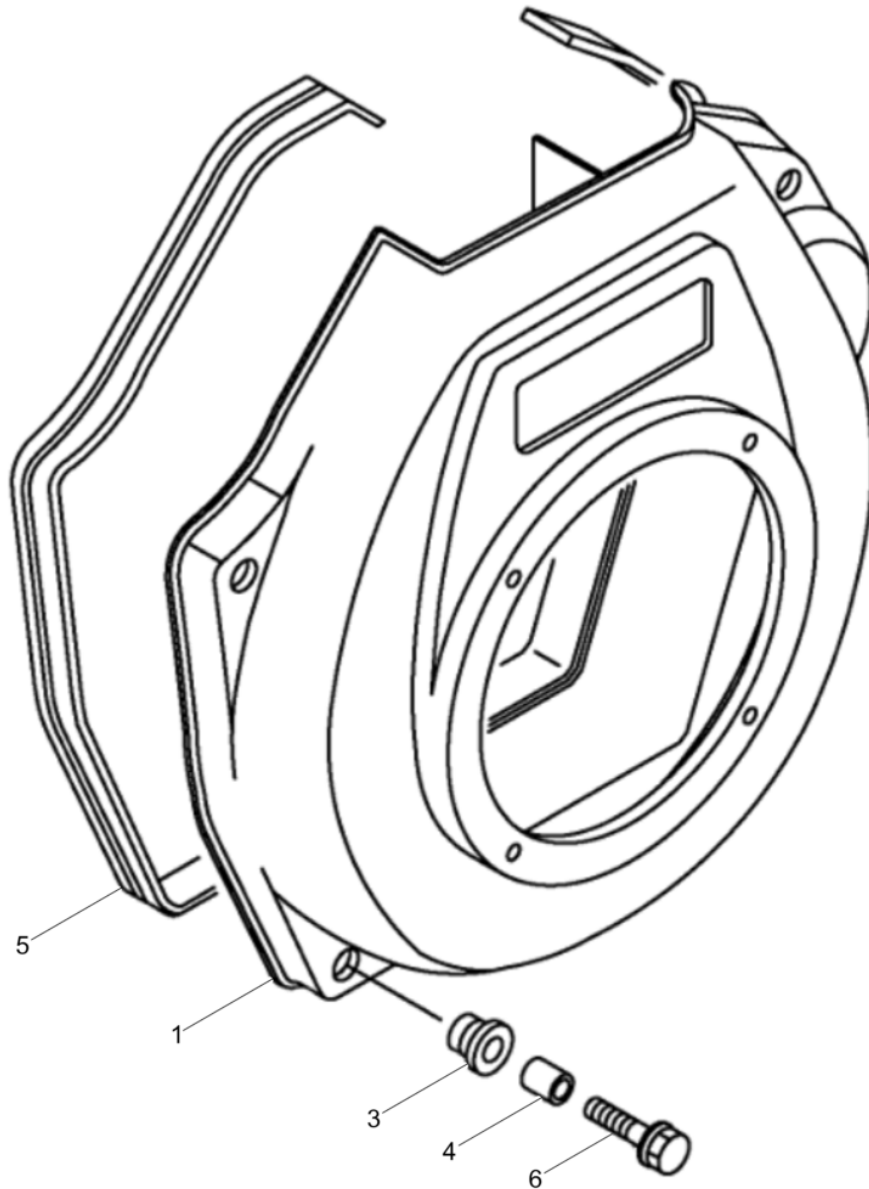

Pos. Item	Artikel Nr. Item no.	Pc.	Unit	Beschreibung Descripción	Description Description	Abm. Dim.	Norm Standard
						Drehmoment Torque	Schmierstoff Lubricant
1	5100000735	1	pc	Gehäuse Carcasa	Housing Carter		
3	5000213238	4	pc	Tülle Ojal	Grommet Passe-fil		
4	5000210542	4	pc	Hülse Collar	Sleeve Douille		
5	5100000751	1	pc	Dichtung Junta	Gasket Joint		
6	5000213240	4	pc	Flanschschraube Tornillo de brida	Flange screw Vis de bride		

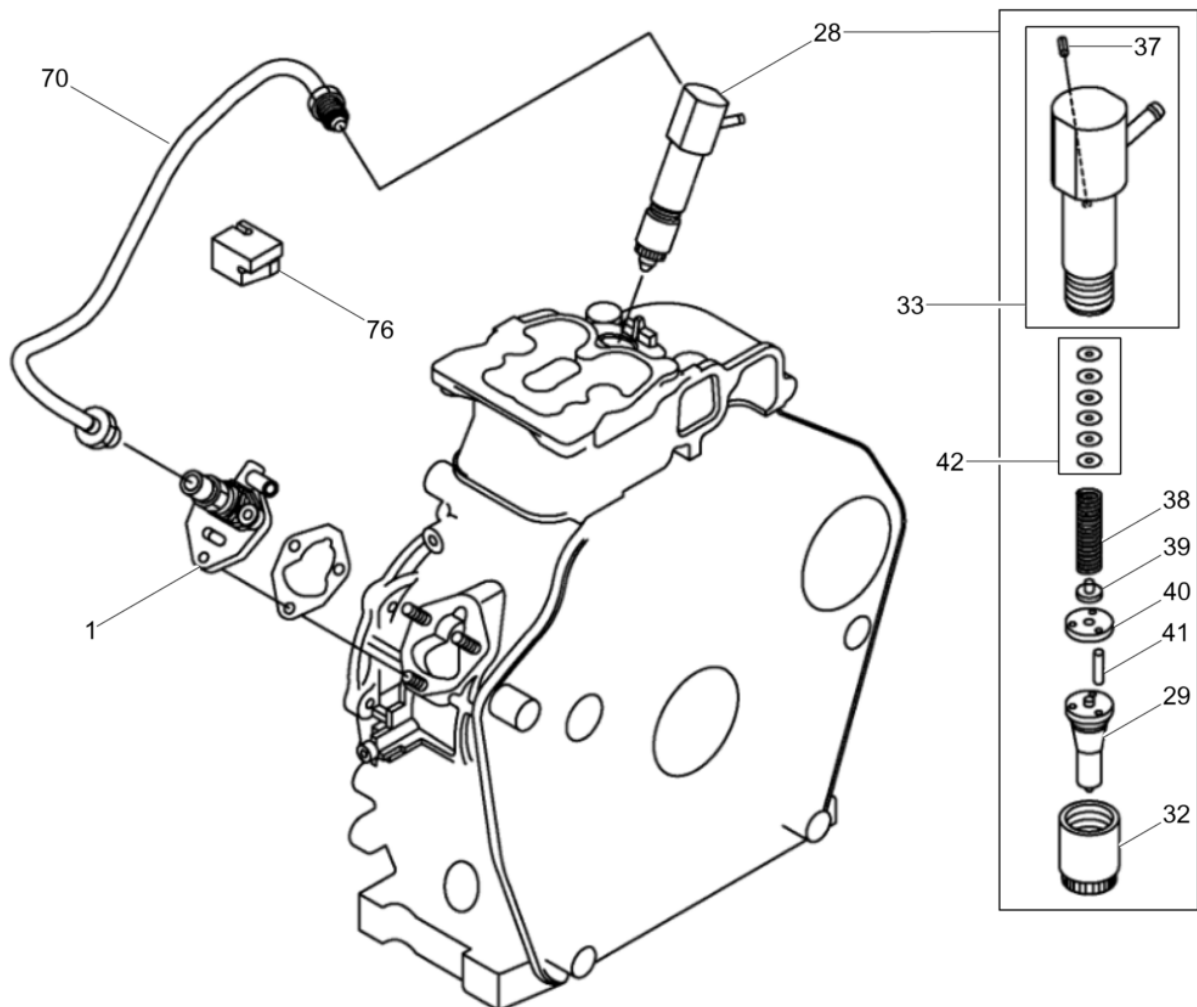

Pos. Item	Artikel Nr. Item no.	Pc.	Unit	Beschreibung Descripción	Description Description	Abm. Dim.	Norm Standard
						Drehmoment Torque	Schmierstoff Lubricant
1	5100061535	1	pc	Einspritzpumpe Bomba de inyección decombustible	Injection pump Pompe d'injection		
28	5100061536	1	pc	Einspritzventil Kpl. Válvula de inyección cpl.	Injection valve cpl. Soupape d'injection cpl.		
29	5100061537	1	pc	Einspritzventil Kpl. Válvula de inyección cpl.	Injection valve cpl. Soupape d'injection cpl.		
32	5000073728	1	pc	Mutter Tuerca	Nut Écrou		
33	5100000753	1	pc	Düsenhalter Kpl. Portainyector cpl.	Injector holder cpl. Porte-injecteur cpl.		
37	5100000763	1	pc	Spannstift Pasador de sujeción	Spring pin Goupille élastique	2,5Ax6	
38	5000073729	1	pc	Feder Resorte	Spring Ressort		
39	5000073730	1	pc	Federgehäuse Carcasa de resorte	Spring housing Logement du ressort		
40	5000073731	1	pc	Platte Placa	Plate Plaque		
41	5000073732	2	pc	Stift Pasador	Pin Goupille		
42	5200020198	1	pc	Ausgleichscheiben Juego de laminillas	Shim set Jeu de cales		
70	5000217880	1	pc	Einspritzleitung Tubería inyección	Injection pipe Tuyau d'injection		
76	5000217881	1	pc	Stütze Soporte	Support Bute		

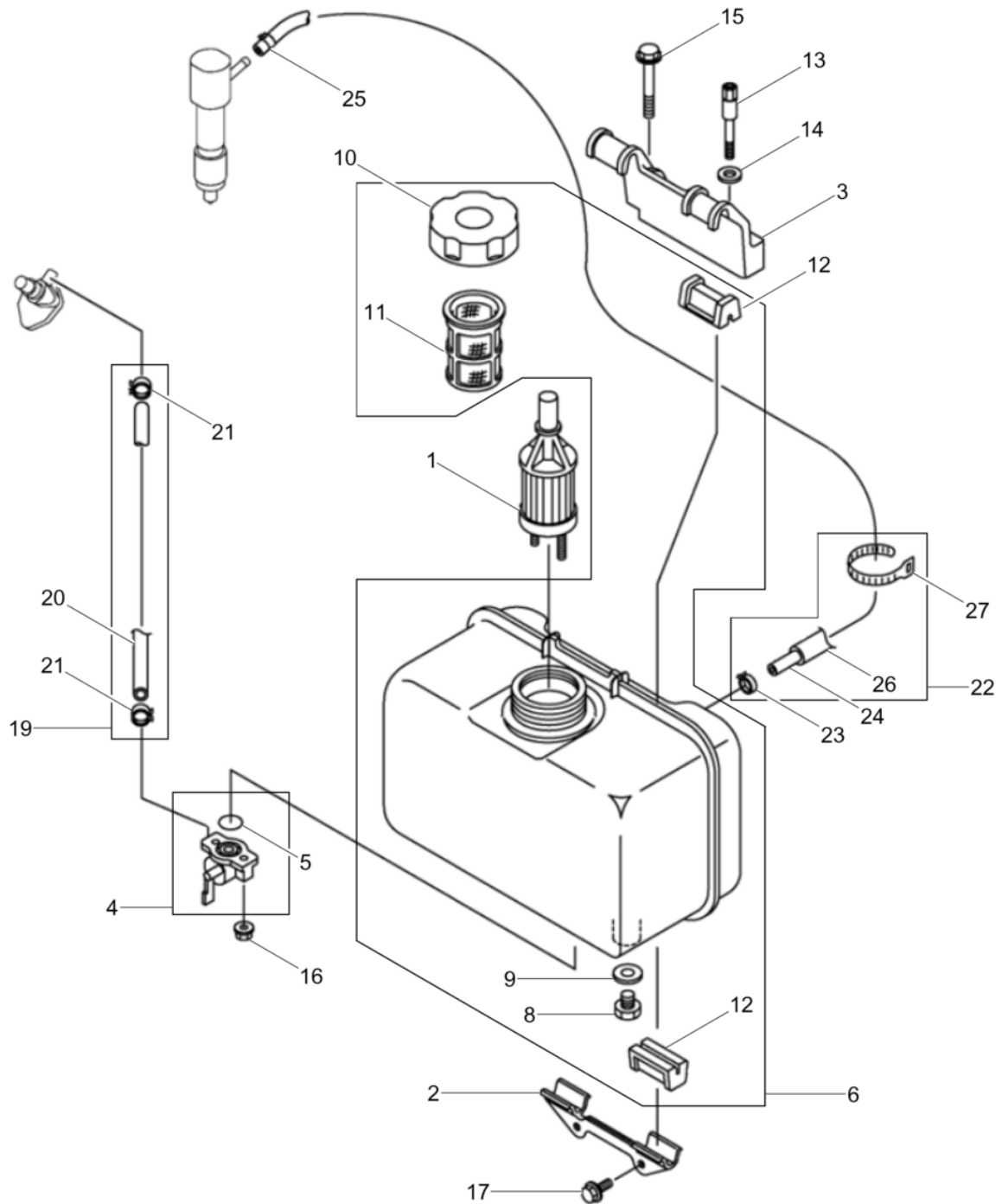

Pos. Item	Artikel Nr. Item no.	Pc.	Unit	Beschreibung Descripción	Description Description	Abm. Dim.	Norm Standard
						Drehmoment Torque	Schmierstoff Lubricant
1	5100061538	1	pc	Kraftstofffilter Kpl. Filtro de combustible cpl.	Fuel filter cpl. Filtre à carburant cpl.		
2	5000217876	1	pc	Konsole Consola	Console Console		
3	5000217877	1	pc	Tankhalterung Soporte	Fixing device Bague de retenue		
4	5100059739	1	pc	Kraftstoffhahn Kpl. Llave de combustible cpl.	Fuel cock cpl. Robinet d'essence cpl.		
5	5000153986	1	pc	O-Ring Anillo-o	O-ring Joint torique		
6	5100061540	1	pc	Kraftstofftank Kpl. Depósito de combustible cpl.	Fuel tank cpl. Réservoir à essence cpl.		
8	5000213242	1	pc	Verschlusschraube Tapón roscado	Screw plug Vis de fermeture		
9	5000119882	1	pc	Dichtung Junta	Gasket Joint		
10	5000213241	1	pc	Kappe Tapa	Cap Chapeau		
11	5100059741	1	pc	Kraftstofffilter Filtro de combustible	Fuel filter Filtre à carburant		
12	5100059743	4	pc	Puffer Amortiguador	Shockmount Silentbloc		
13	5000217878	1	pc	Bolzen Perno	Bolt Boulon		
14	5000085567	1	pc	Scheibe Arandela	Washer Rondelle		
15	5200019879	1	pc	Sechskantflanschschraube Tornillo hexagonal de brida	Hexagonal flange head screw Vis hexagonale de bride	M8 x 45 25Nm/18ft.lbs	
16	5000119722	2	pc	Mutter Tuerca	Nut Ecrou	M6	
17	5000073659	2	pc	Schraube Tornillo	Screw Vis	M6 x 16 10Nm/7ft.lbs	
19	5000210560	1	pc	Kraftstoffleitung Kpl. Tubo de combustible compl.	Fuel pipe cpl. Conduite de carburant compl.		
20	5000119891	1	pc	Rohr Tubo	Pipe Tube		
21	5000217931	2	pc	Schelle Abrazadera	Clamp Attache		
22	5100000750	1	pc	Leitung Kpl. Tubo cpl.	Pipe cpl. Tuyau cpl.		
23	5200020209	1	pc	Befestigung Clip	Clip Clip		
24	5100061541	1	pc	Rücklaufleitung Tubulure de retorno	Return pipe Cond. de refoulement		
25	5100000762	1	pc	Schelle Abrazadera	Clamp Agrafe		
26	5000217927	1	pc	Schutzschlauch Manguera de protección	Protective hose Gaine de protection		
27	5000217929	1	pc	Schelle Abrazadera	Clamp Attache		

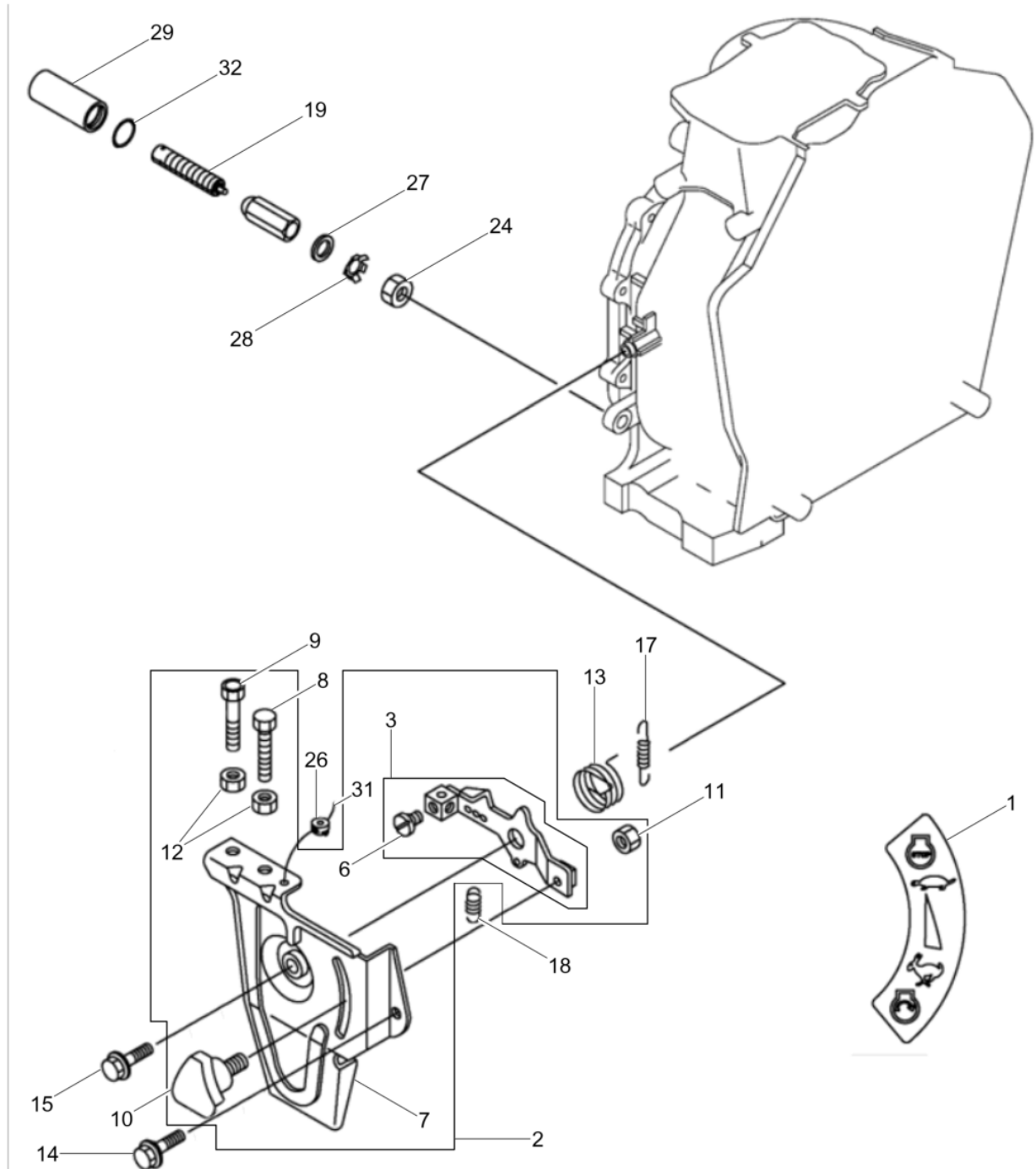



Pos. Item	Artikel Nr. Item no.	Pc.	Unit	Beschreibung Descripción	Description Description	Abm. Dim.	Norm Standard
						Drehmoment Torque	Schmierstoff Lubricant
1	5100000745	1	pc	Aufkleber Calcomanía	Label Autocollant		
2	5100031899	1	pc	Gasreglerkonsole Ménsula-acelerador	Throttle control bracket Console-commande des gaz		
3	5100000727	1	pc	Hebel Palanca	Lever Levier		
6	5100000764	1	pc	Schraube Tornillo	Screw Vis	M5x8	
7	5100000728	1	pc	Halterung Soporte	Bracket Équerre		
8	5000210538	1	pc	Bolzen Perno	Bolt Boulon		
9	5000217829	1	pc	Einstellschraube Tornillo	Screw Vis		
10	5000073784	1	pc	Griff Empuñadura	Handle Poignée		
11	5100039293	1	pc	Sechskantmutter Tuerca hexagonal	Hexagon nut Écrou hexagonal		
12	5100031900	2	pc	Mutter Tuerca	Nut Ecrou	M6	
13	5000210536	1	pc	Rückholfeder Resorte	Spring Ressort		
14	5000210533	1	pc	Sechskantschraube Tornillo hexagonal	Hexagonal head cap screw Vis à tête hexagonale	M6 x 14	
15	5000150361	1	pc	Flanschschraube Tornillo de brida	Flange screw Vis de bride	M6 x 20	
17	5100061542	1	pc	Zugfeder Resorte de tracción	Tension spring Ressort de traction		
18	5100030564	1	pc	Rückholfeder Resorte	Spring Ressort		
19	5000217884	1	pc	Einstellschraube Tornillo	Screw Vis		
24	5000210530	1	pc	Sechskantmutter Tuerca hexagonal	Hexagon nut Écrou hexagonal	M10	
26	5000213254	1	pc	Plombe Soporte cable	Cable holder Attache		
27	5000153982	1	pc	Scheibe Arandela	Washer Rondelle		
28	5000153983	1	pc	Platte Placa	Plate Plaque		
29	5000153984	1	pc	Deckel Tapa	Cover Couvercle		
31	5000119859	1	pc	Kabel Cable eléctrico	Electric wire Fil ressortant	0,6	
32	5000153986	1	pc	O-Ring Anillo-o	O-ring Joint torique		

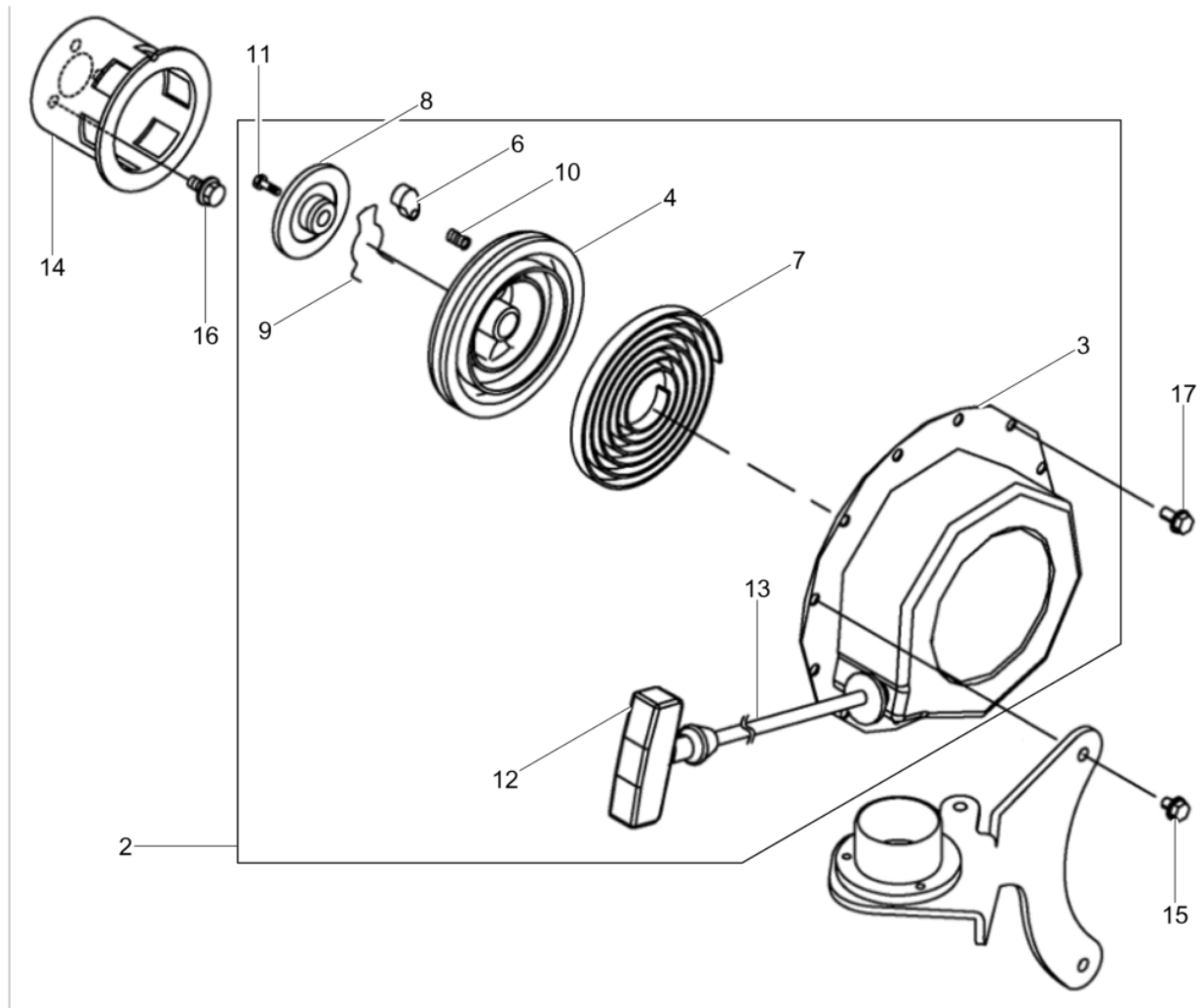

Pos. Item	Artikel Nr. Item no.	Pc.	Unit	Beschreibung Descripción	Description Description	Abm. Dim.	Norm Standard
						Drehmoment Torque	Schmierstoff Lubricant
2	5000210544	1	pc	Reversierstarter Arrancador	Rewind starter Démarrreur		
3	5000210545	1	pc	Gehäuse Carcasa	Housing Carter		
4	5000217921	1	pc	Seilscheibe Polea	Pulley Poulie		
6	5100061544	1	pc	Sperrklinke Trinquete	Ratchet Cliquet		
7	5000210548	1	pc	Spiralfeder Resorte en espiral	Brush spring Ressort spirale		
8	5000210549	1	pc	Klinkenteller Disco	Disc Disque		
9	5000210550	1	pc	Feder Resorte	Spring Ressort		
10	5000210551	1	pc	Rückholfeder Resorte	Spring Ressort		
11	5000210552	1	pc	Schraube Tornillo	Screw Vis		
12	5000210553	1	pc	Startergriff Manija	Handle Poignée		
13	5000210554	1	pc	Starterseil Cuerda	Rope Corde		
14	5000210555	1	pc	Mitnehmertopf Tambor de arrastre	Starter pulley Tôle d'entraînement		
15	5000119905	2	pc	Schloßschraube Tornillo	Mushroom head bolt Vis	M 6x 8	
16	5000119897	3	pc	Schraube Tornillo	Screw Vis		
17	5000119897	2	pc	Schraube Tornillo	Screw Vis		

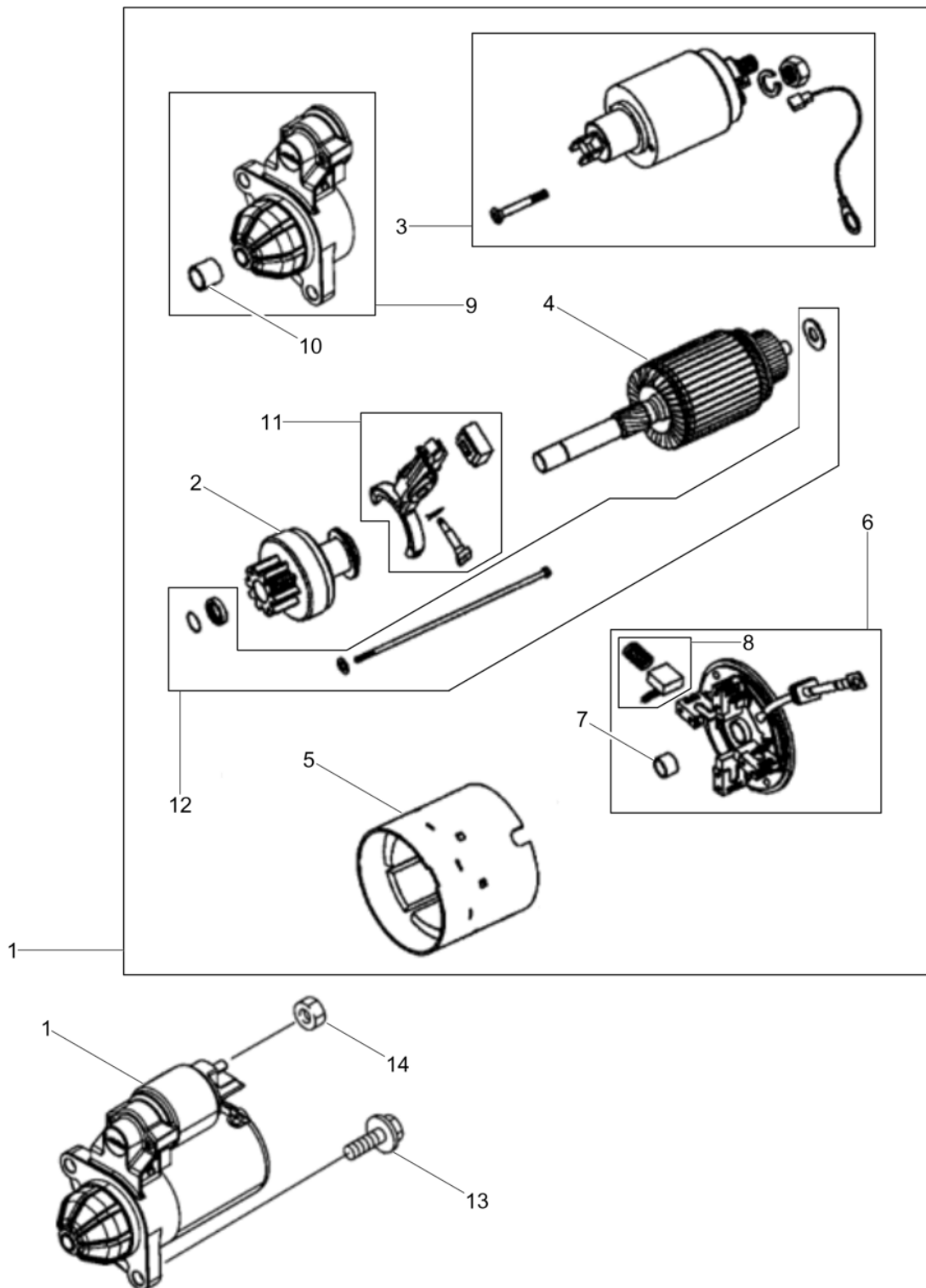

Pos. Item	Artikel Nr. Item no.	Pc.	Unit	Beschreibung Descripción	Description Description	Abm. Dim.	Norm Standard
						Drehmoment Torque	Schmierstoff Lubricant
1	5100059768	1	pc	Starter Kpl. Starter cpl.	Starter cpl. Starter cpl.		
2	5000217543	1	pc	Ritzel Piñon diferencial	Pinion gear Pignon		
3	5000217540	1	pc	Magnetschalter Interruptor	Magnetic switch Commutateur		
4	5100030569	1	pc	Motorläufer Inducido del motor	Motor armature Rotor		
5	5100030570	1	pc	Erregerspule Bobina	Coil Bobine		
6	5000217546	1	pc	Deckel Kpl. Tapa	Cover Couvercle		
7	5000217548	1	pc	Buchse Buje	Bushing Douille		
8	5000217547	4	pc	Bürstenhalter Soporte de escobillas	Brush holder Porter balais		
9	5000217538	1	pc	Gehäuse Carcasa	Housing Enveloppe		
10	5000217539	1	pc	Buchse Buje	Bushing Douille		
11	5000217541	1	pc	Schalthebel Kpl. Palanca de cambios cpl.	Shift lever cpl. Lever de change cpl.		
12	5100030572	2	pc	Gewindebolzen Perno roscado	Threaded bolt Boulon fileté		
13	5000210585	2	pc	Schraube Tornillo	Screw Vis	M10 x 30	
14	5000119919	1	pc	Mutter Tuerca	Nut Ecrou	M8	

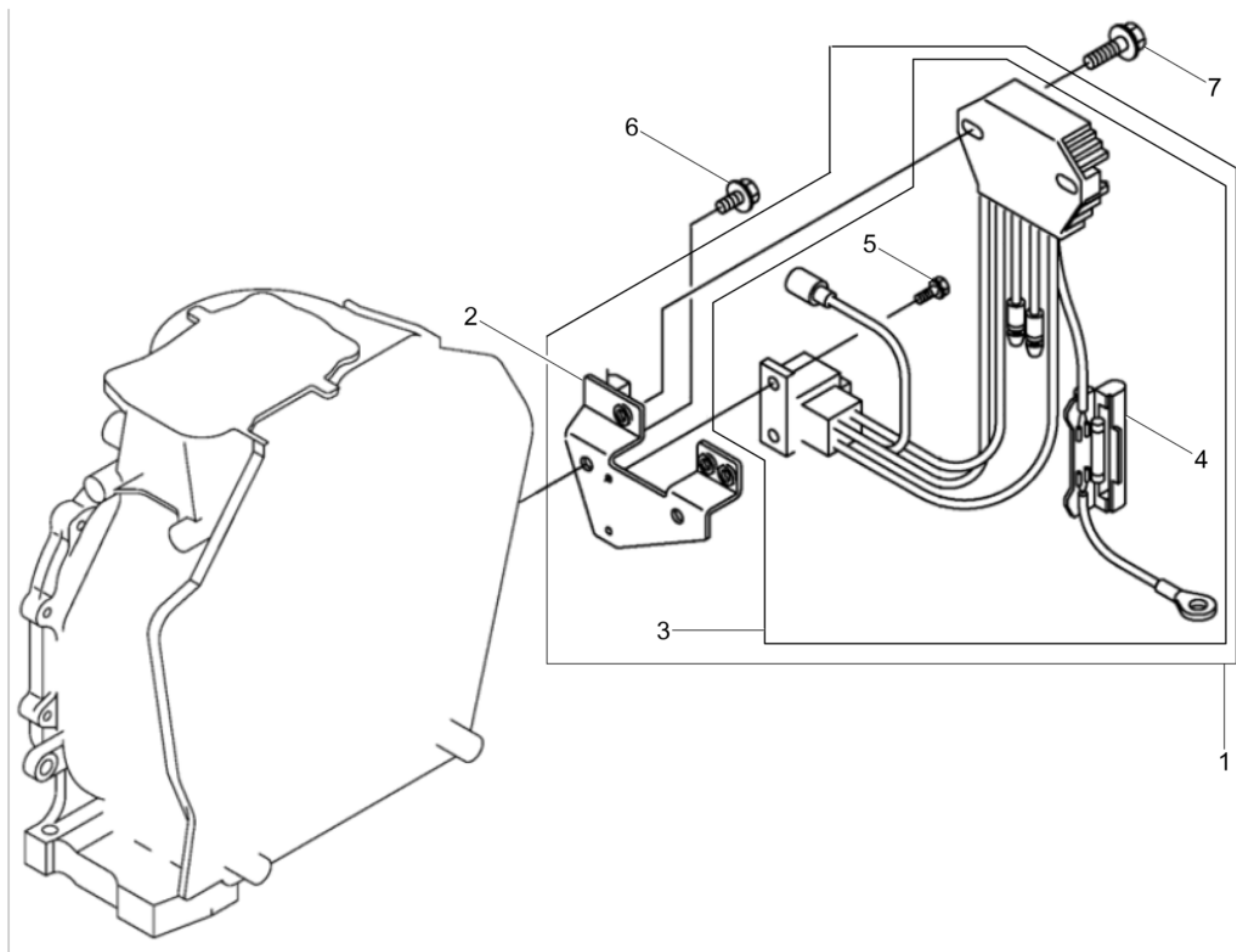

Pos. Item	Artikel Nr. Item no.	Pc.	Unit	Beschreibung Descripción	Description Description	Abm. Dim.	Norm Standard
						Drehmoment Torque	Schmierstoff Lubricant
1	5100059769	1	pc	Reglerschalter Kpl. Regulador cpl.	Regulator cpl. Régulateur cpl.		
2	5100030573	1	pc	Halter Soporte	Bracket Équerre		
3	5100000757	1	pc	Kabelbaum Disp. del cable de elevación	Cable harness Faisceau de câbles		
4	5100000758	1	pc	Sicherung Fusible	Fuse Fusible		
5	5000210593	2	pc	Schraube Tornillo	Screw Vis	M4 x 10	
6	5000119897	2	pc	Schraube Tornillo	Screw Vis		
7	5000150361	2	pc	Flanschschraube Tornillo de brida	Flange screw Vis de bride	M6 x 20	

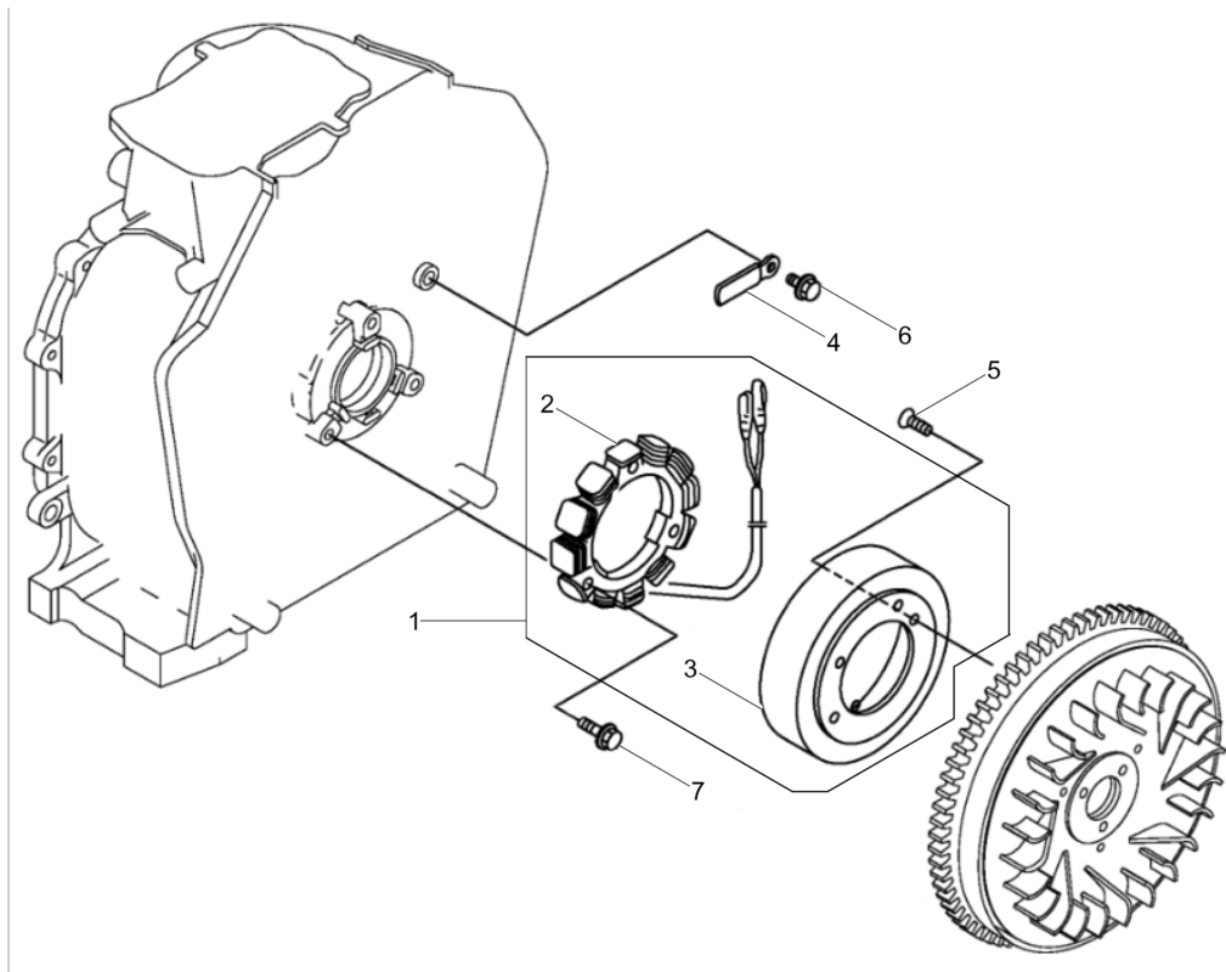



Pos. Item	Artikel Nr. Item no.	Pc.	Unit	Beschreibung Descripción	Description Description	Abm. Dim.	Norm Standard
						Drehmoment Torque	Schmierstoff Lubricant
1	5100000759	1	pc	Lichtmaschine Dinamo	Dynamo Dynamo		
2	5100000760	1	pc	Stator Estator	Stator Stator		
3	5100000761	1	pc	Rad Rueda	Wheel Roue		
4	5100059770	1	pc	Schelle Abrazadera	Clamp Agrafe		
5	5100030574	3	pc	Schraube Tornillo	Screw Vis	M6	
6	5000119897	1	pc	Schraube Tornillo	Screw Vis		
7	5000150361	3	pc	Flanschschraube Tornillo de brida	Flange screw Vis de bride	M6 x 20	



2



3



4



5



13



6



11

Pos. Item	Artikel Nr. Item no.	Pc.	Unit	Beschreibung Descripción	Description Description	Abm. Dim.	Norm Standard
						Drehmoment Torque	Schmierstoff Lubricant
2	5100000741	1	pc	Aufkleber Calcomanía	Label Autocollant		
3	5100030576	1	pc	Aufkleber Calcomanías	Labels Autocollants		
4	5100000742	1	pc	Aufkleber Calcomanía	Label Autocollant		
5	5100030577	1	pc	Aufkleber Calcomanías	Labels Autocollants		
6	5000210603	1	pc	Luftfilterdichtung Junta filtro de aire	Air filter seal Joint filtre à air		
11	5100000744	1	pc	Aufkleber Calcomanía	Label Autocollant		
13	5100000745	1	pc	Aufkleber Calcomanía	Label Autocollant		

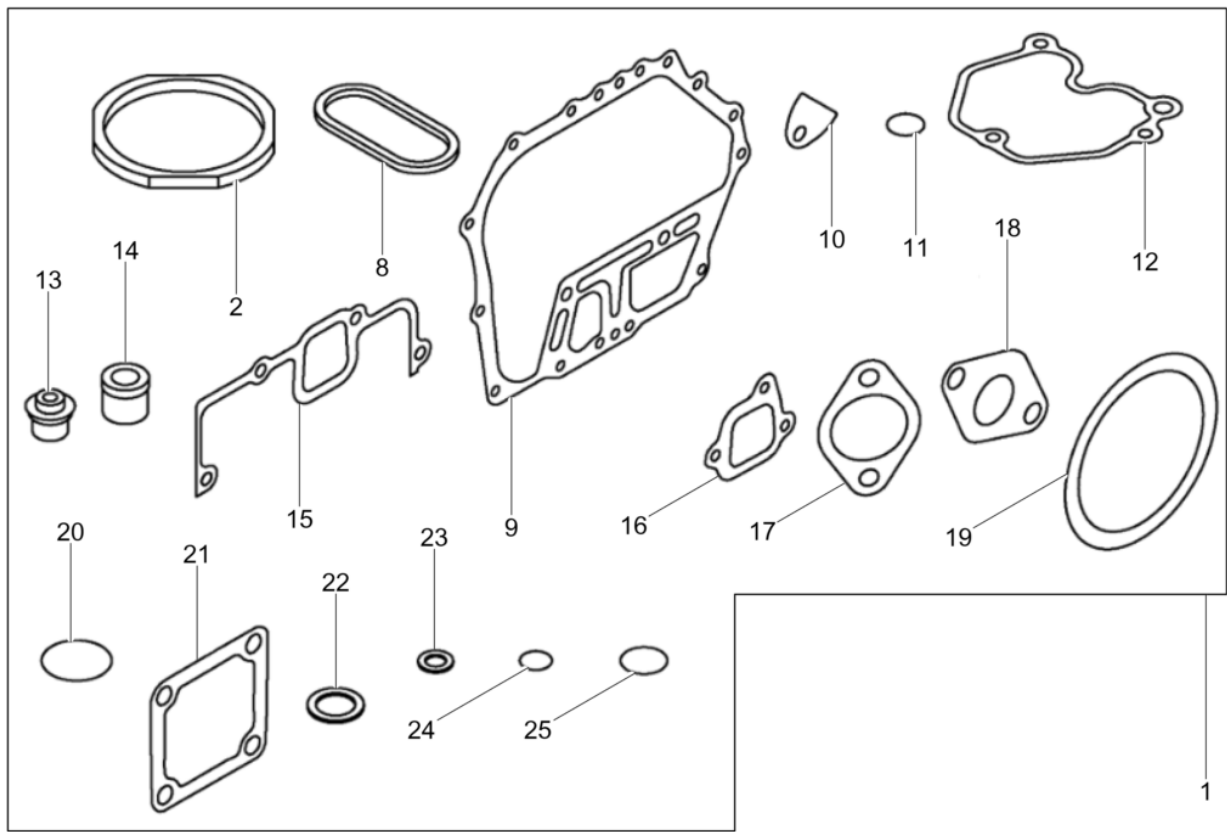

Pos. Item	Artikel Nr. Item no.	Pc.	Unit	Beschreibung Descripción	Description Description	Abm. Dim.	Norm Standard
						Drehmoment Torque	Schmierstoff Lubricant
1	5100000746	1	pc	Dichtungssatz Juego de juntas	Set-gaskets Jeu de joints		
2	5100031962	1	pc	Kopfdichtung Junta de culata	Head gasket Joint de culasse		
8	5000210612	1	pc	O-Ring Anillo-o	O-ring Joint torique		
9	5000210613	1	pc	Kurbelwellendichtung Cigüeñal junta	Crankshaft gasket Vilebrequin joint		
10	5000073612	1	pc	Dichtung Junta	Gasket Joint		
10	5000210614	1	pc	Dichtung Junta	Gasket Joint		
11	5100039305	1	pc	O-Ring Anillo-o	O-ring Bague-o		
12	5000217846	1	pc	Dichtung Junta de estanqueidad	Gasket Garniture		
13	5100031963	1	pc	Dichtung Empaque	Seal Joint		
14	5000119738	1	pc	Dichtung Junta de estanqueidad	Gasket Garniture		
15	5000217852	1	pc	Luftfilterdichtung Junta filtro de aire	Air filter seal Joint filtre à air		
16	5100061545	1	pc	Dichtung Junta	Gasket Joint		
17	5000217900	1	pc	Dichtung Junta de estanqueidad	Gasket Garniture		
18	5000210617	2	pc	Dichtung Junta	Gasket Joint		
19	5000217919	1	pc	Dichtung Junta de estanqueidad	Gasket Garniture		
20	5000210618	2	pc	O-Ring Anillo-o	O-ring Joint torique		
21	5000217930	1	pc	Dichtung Junta de estanqueidad	Gasket Garniture		
22	5000073608	1	pc	Scheibe Arandela	Washer Rondelle		
23	5000119882	2	pc	Dichtung Junta	Gasket Joint		
24	5000073751	1	pc	O-Ring Anillo-o	O-ring Joint torique	15 x 1,3	
25	5000073693	1	pc	O-Ring Anillo-o	O-ring Joint torique	22,4 x 1,8	

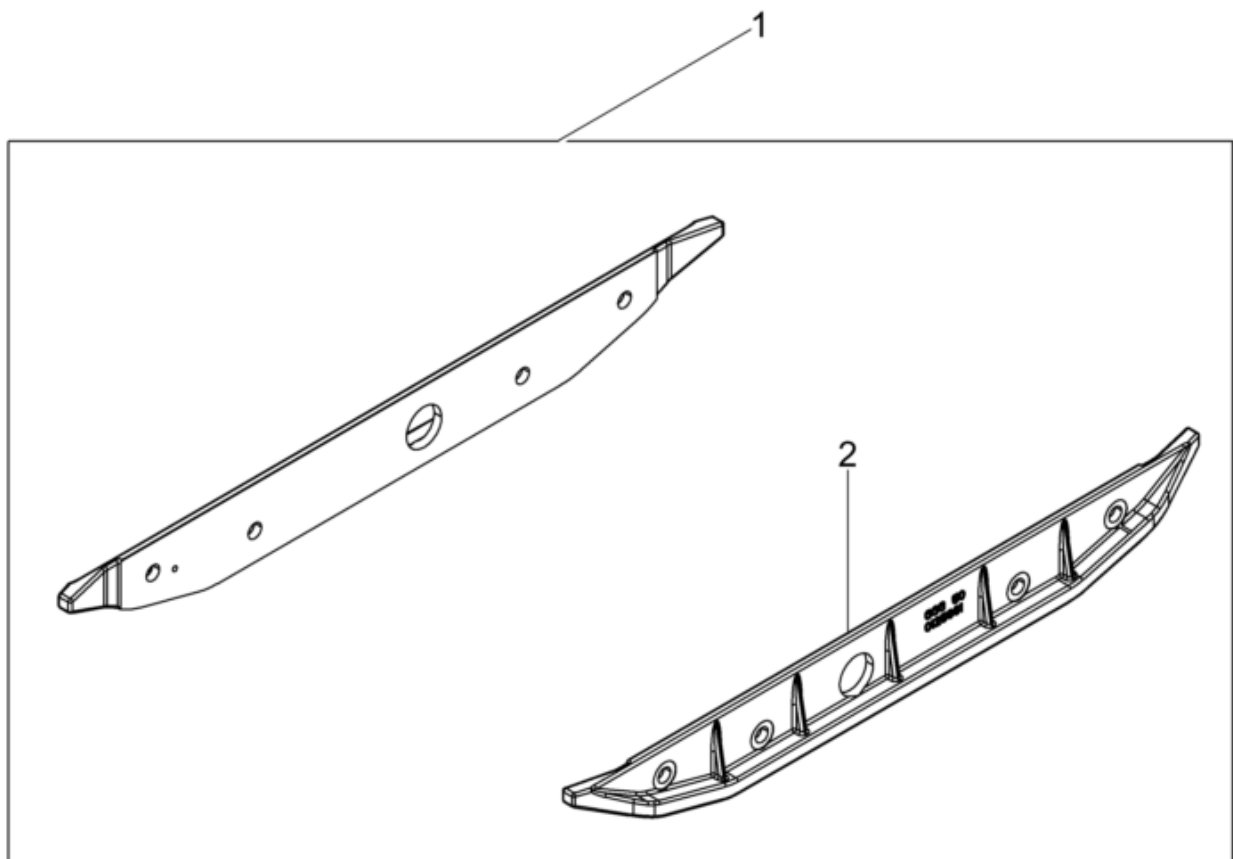

Pos. Item	Artikel Nr. Item no.	Pc.	Unit	Beschreibung Descripción	Description Description	Abm. Dim.	Norm Standard
						Drehmoment Torque	Schmierstoff Lubricant
1	5000126290	1	pc	Anbauplattensatz Juego de placa de extensión	Extension plate kit Jeu de elargisseur	3	
2	5000125662	2	pc	Anbauplatte Placa de extensión	Extension plate Elargisseur	3 cm	

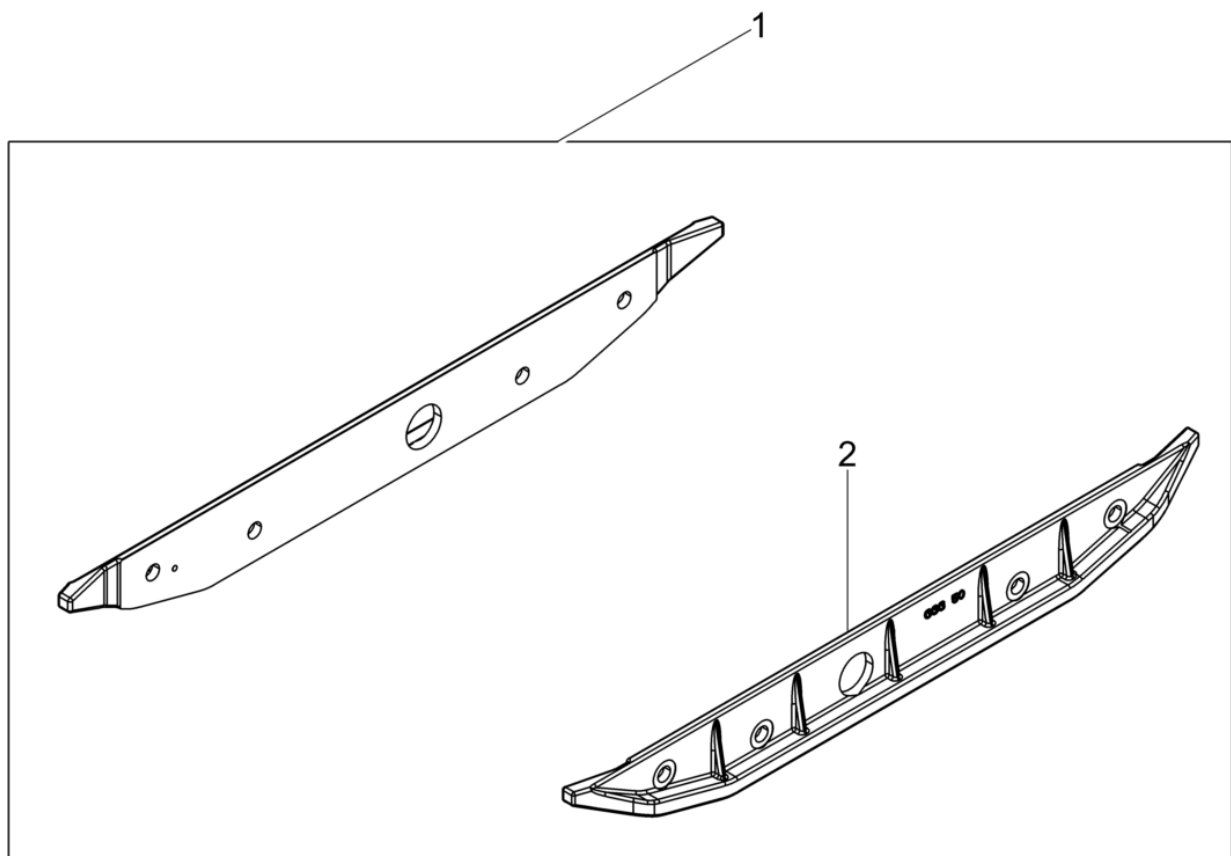



Pos. Item	Artikel Nr. Item no.	Pc.	Unit	Beschreibung Descripción	Description Description	Abm. Dim.	Norm Standard
						Drehmoment Torque	Schmierstoff Lubricant
1	5000045201	1	pc	Anbauplattensatz Juego de placa de extensión	Extension plate kit Jeu de elargisseur	3in	
2	5000044442	2	pc	Anbauplatte Placa de extensión	Extension plate Elargisseur	8 cm	

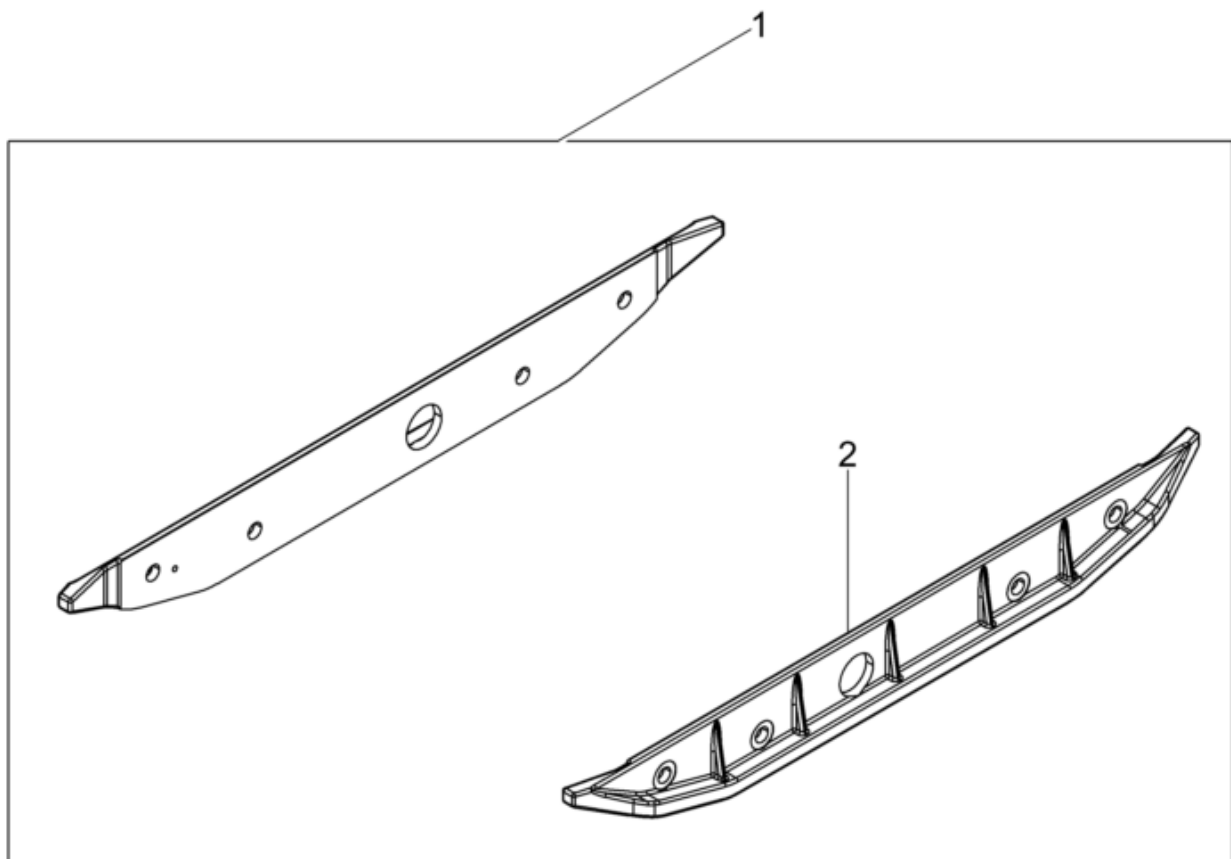

Pos. Item	Artikel Nr. Item no.	Pc.	Unit	Beschreibung Descripción	Description Description	Abm. Dim.	Norm Standard
						Drehmoment Torque	Schmierstoff Lubricant
1	5000043246	1	pc	Anbauplattensatz Juego de placa de extensión	Extension plate kit Jeu de elargisseur	15	
2	5000043245	1	pc	Anbauplatte Placa de extensión	Extension plate Elargisseur	860mm	

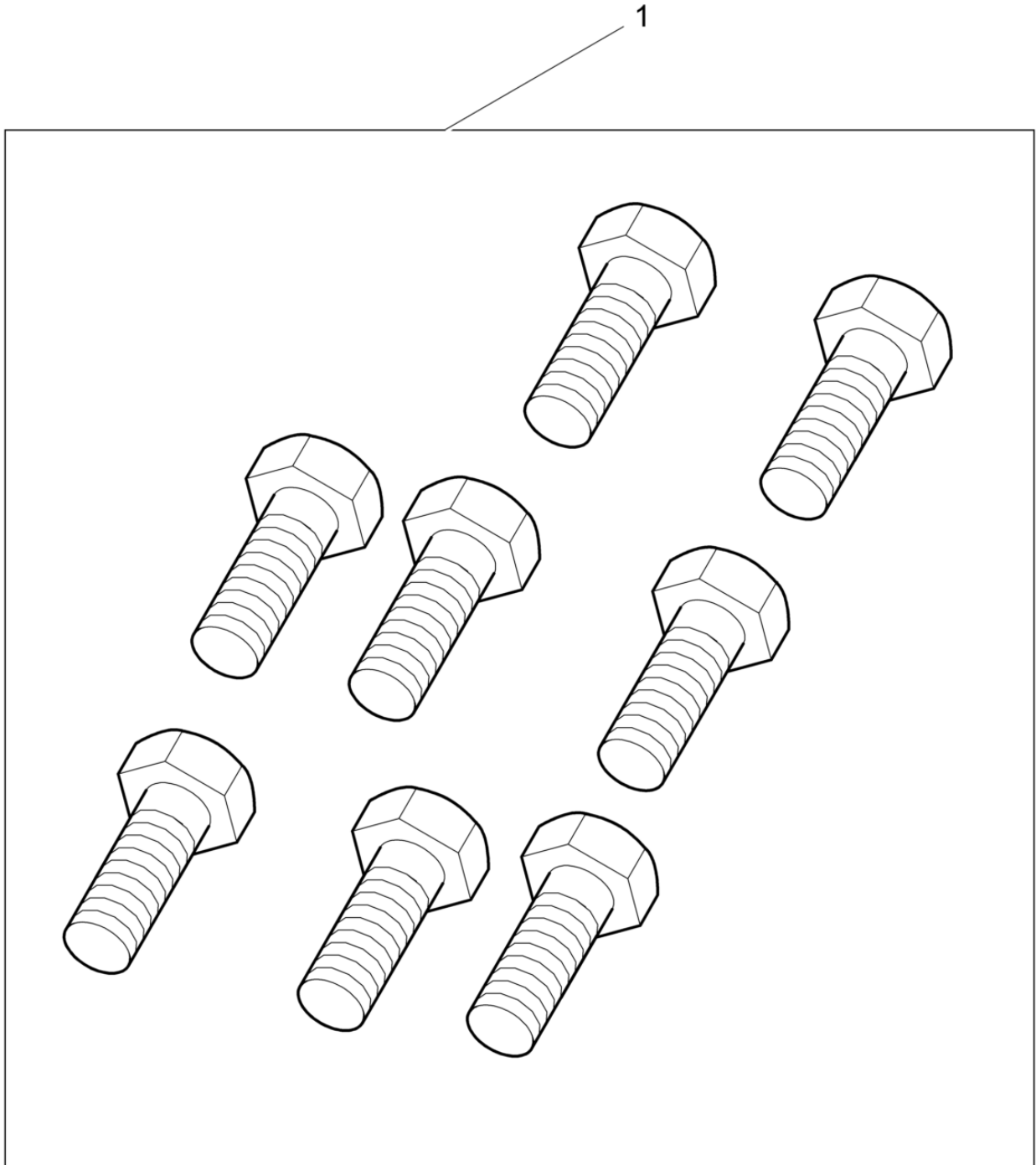

Pos. Item	Artikel Nr. Item no.	Pc.	Unit	Beschreibung Descripción	Description Description	Abm. Dim.	Norm Standard
						Drehmoment Torque	Schmierstoff Lubricant
1	5000067519	1	pc	Schraubensatz Juego de tornillos	Set of screws Jeu de vis		

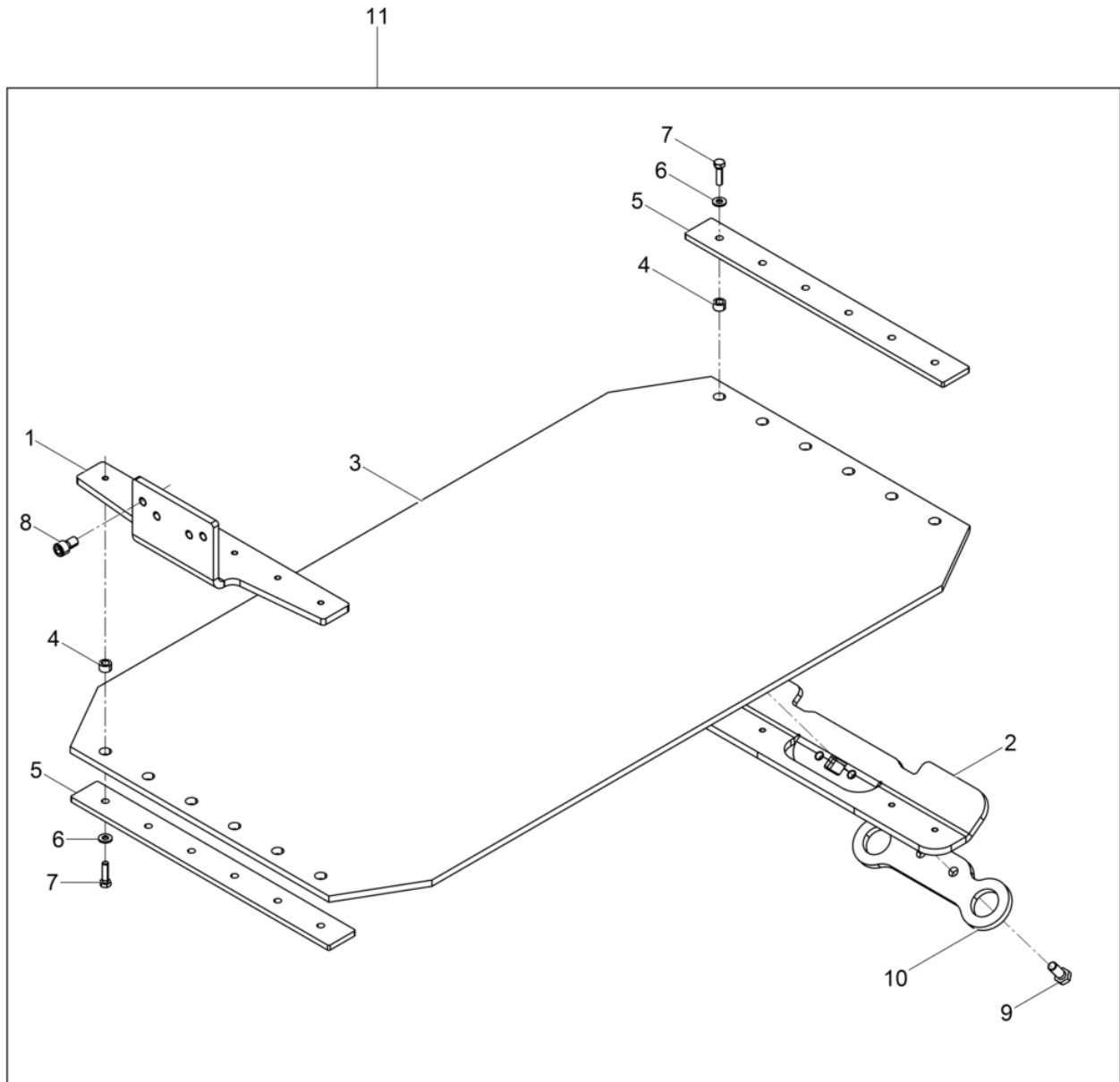

Pos. Item	Artikel Nr. Item no.	Pc.	Unit	Beschreibung Descripción	Description Description	Abm. Dim.	Norm Standard
						Drehmoment Torque	Schmierstoff Lubricant
1	5000202884	1	pc	Winkel Angulo	Angle Angle		
2	5100010936	1	pc	Winkel Hinten Angulo atrás	Angle rear Angle arrière		
3	5000058330	1	pc	Kunststoffplatte Juego de lamina de uretano	Urethane plate Dispositif de glissement		
4	5000047577	10	pc	Buchse Buje	Bushing Douille		
5	5000058358	2	pc	Leiste Listón	Bar Listeau		
6	5000033198	10	pc	Spannscheibe Arandela elástica	Lockwasher Rondelle de ressort		DIN6796
7	5000011456	10	pc	Sechskantschraube Tornillo hexagonal	Hexagonal head cap screw Vis à tête hexagonale		
8	5000011531	4	pc	Zylinderschraube Tornillo cilíndrico	Cheese head screw Vis à tête cylindrique	M12 x 20 86Nm/63ft.lbs	ISO4762
9	5000011423	2	pc	Sechskantschraube Tornillo hexagonal	Hexagonal head cap screw Vis à tête hexagonale	M12 x 30 210Nm/155ft.lbs	DIN933
10	5100010935	1	pc	Blech Chapa	Plate Tôle		
11	5100009997	1	pc	Gleitvorrichtung Placa de deslizamientopgv 4045-5545	Urethane pad pgv 4045-5545 Jeu de tapis en polyuréthane		

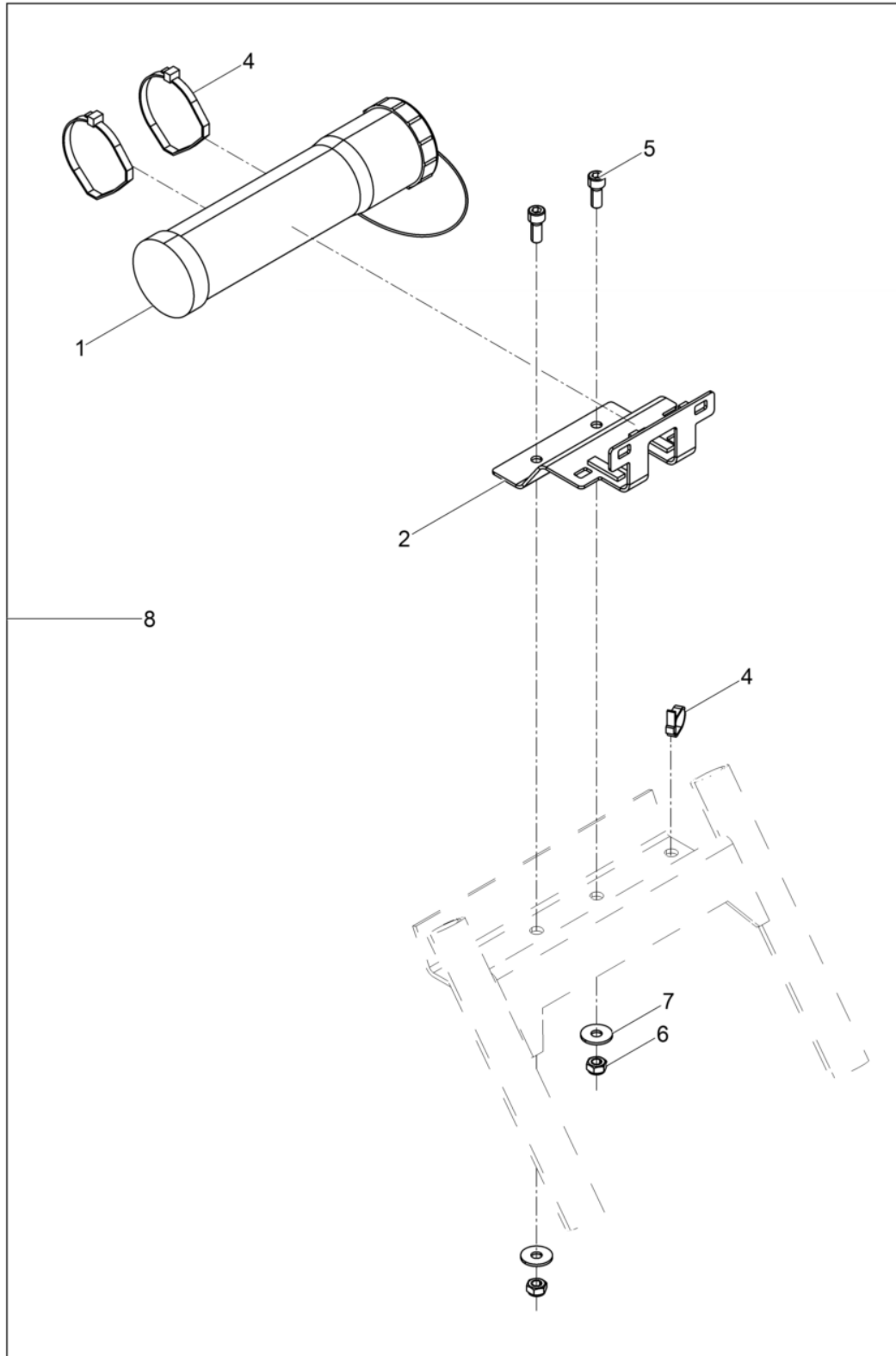



Pos. Item	Artikel Nr. Item no.	Pc.	Unit	Beschreibung Descripción	Description Description	Abm. Dim.	Norm Standard
						Drehmoment Torque	Schmierstoff Lubricant
1	5100026895	1	pc	Dokumentenbehälter Saporte posa documentos	Document-box Receptable de documents		
2	5100028391	1	pc	Halterung Soporte	Bracket Équerre		
4	5000047388	3	pc	Kabelbinder Fijación de cables	Zip tie Attache de câble		
5	5000011535	2	pc	Zylinderschraube Tornillo cilíndrico	Cheese head screw Vis à tête cylindrique	49Nm/36ft.lbs	
6	5000017313	2	pc	Sechskantmutter Tuerca hexagonal	Hexagon nut Écrou hexagonal		
7	5000010375	2	pc	Scheibe Arandela	Flat washer Rondelle		DIN9021
8	5100028390	1	pc	Nachrüstsatz Rental DPU40../45../55.. Juego de modificación dpu40../45../55..	Kit-retrofit dpu40../45../55.. Lot de rattrapage		







**WACKER  
NEUSON**

