



**WACKER
NEUSON**

Ersatzteilkatalog
Spare parts catalog
Catálogo de piezas de repuesto
Catalogue de pièces de rechange

**Vibrationsplatte
Vibratory plate
Plancha vibratoria
Plaque vibrante**

DPS1850H BASIC



Type	DPS1850H BASIC
Material Number	5000610032
Version	107
Language	de en es fr



www.wackerneuson.com

Copyright © 01.2021
Wacker Neuson Produktion GmbH & Co. KG
Printed in Germany.
All rights reserved.

Ein Typenschild mit Typ, Artikelnummer, Version und Maschinen-Nummer ist an jedem Gerät angebracht. Die Daten von diesem Schild bitte notieren, damit sie auch bei Verlust oder Beschädigung des Schildes noch vorhanden sind. Der Typ, die Artikelnummer, die Versions-Nummer und die Maschinen-Nummer sind bei der Ersatzteilbestellung oder Nachfragen bezüglich Service-Informationen stets erforderlich.

Bei den in den Ersatzteillisten fettgedruckten Nummern handelt es sich um empfohlene Ersatzteile. Dies bedeutet, daß diese Teile bei normalen Anwendungsbedingungen natürlicher Abnutzung ausgesetzt sind und gelegentlich ersetzt oder überarbeitet werden müssen. Es wird geraten, diese Teile auf Lager bereit zu haben, um für Service-Arbeiten an diesem Gerät vorbereitet zu sein. Lagerbestände für diese und andere Teile, welche für ausgiebigere Reparaturarbeiten benötigt werden, können je nach Service-Gewohnheiten der einzelnen Kunden variieren.

Die Nummern meines Gerätes sind:

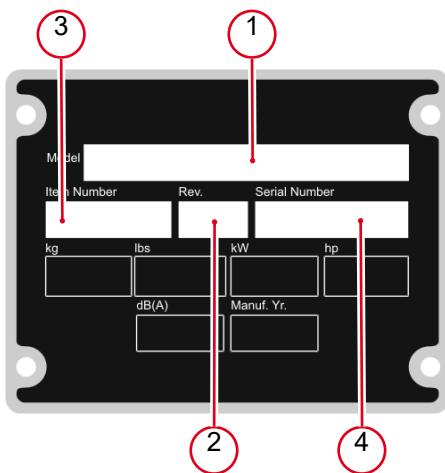

1. Typ
2. Version
3. Artikel-Nr.
4. Maschinen-Nr.

Umrechnungstabelle

Volumeneinheit	
1 ml	0.034 US fl.oz.
1 l	0.260 gal
Längeneinheit	
1 mm	0.039 in
1 m	3.280 ft
Gewicht	
1 kg	2.200 lbs
1 g	0.035 oz
Geschwindigkeit	
1 km/h	0.620 mph
Drehmoment	
1 Nm	0.740 ft.lbs

A nameplate listing the Model Number, Item Number, Revision, and Serial Number is attached to each unit. Please record the information found on this plate so it will be available should the nameplate become lost or damaged. When ordering parts or requesting service information, you will always be asked to specify the model, item number, revision number, and serial number of the unit.

Part Numbers appearing in boldface type are recommended spare parts. This means that these parts are subject to wear under normal operating conditions and may require periodic service or replacement. It is recommended that these items be stocked to meet the expected service requirements of this model. Actual stocking quantities of these and other parts used in more extensive repairs will depend on the service practices of each customer.

My machine's numbers are:



1. Model
2. Revision
3. Item No.
4. Serial No.

Conversion table

Volume unit	
1 ml	0.034 US fl.oz.
1 l	0.260 gal
Unit of length	
1 mm	0.039 in
1 m	3.280 ft
Weight	
1 kg	2.200 lbs
1 g	0.035 oz
Speed	
1 km/h	0.620 mph
Torque	
1 Nm	0.740 ft.lbs

Una placa de identificación con el modelo, número de referencia, nivel de revisión y número de serie ha sido añadida en cada máquina. Favor de anotar los datos en la placa en caso de que la placa de identificación sea destruida o perdida. En todos los pedidos para repuestos necesita siempre el modelo, el número de referencia, el nivel de revisión y el número de serie de la máquina en cuestión.

Los números de partes en negritas en las Listas Ilustradas de Partes son los repuestos recomendados, esto quiere decir que estas partes se desgastarán bajo circunstancias de funcionamiento normales y pueden requerir servicio periódico o su reemplazo. Se recomienda que el cliente mantenga un abastecimiento adecuado de estas partes para poder satisfacer la demanda requerida por el servicio a la máquina. La cantidad de repuestos que el cliente necesitará para reparaciones dependerá de la póliza de servicio de cada cliente.

Los números de mi máquina son:

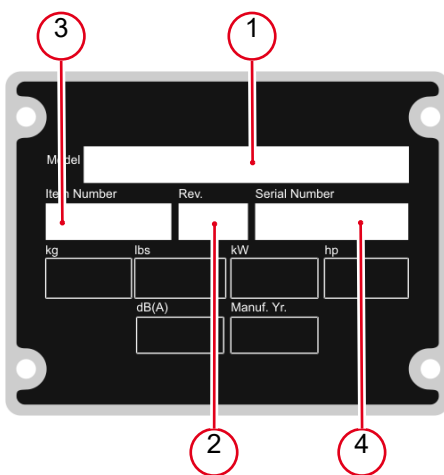

1. Modelo
2. Nivel de revisión
3. Número de referencia
4. Número de Serie

Tabla de conversión

Unidad de volumen	
1 ml	0.034 US fl.oz.
1 l	0.260 gal
Unidad de longitud	
1 mm	0.039 in
1 m	3.280 ft
Peso	
1 kg	2.200 lbs
1 g	0.035 oz
Velocidad	
1 km/h	0.620 mph
Par de apriete	
1 Nm	0.740 ft.lbs

Une plaque signalétique mentionnant le modèle, le numéro de référence, le niveau de revision et le numéro de série est fixée sur chaque machine. Veuillez noter les informations relevées sur cette plaque de façon à ce qu'elles soient toujours disponibles si la plaque signalétique venait à être perdue ou endommagée. Lorsque vous commandez des pièces détachées ou vous sollicitez des informations après-vente, on vous demandera toujours de préciser le modèle, le numéro de référence, le niveau de revision et le numéro de série de la machine.

Les numéros de pièces imprimés en caractères gras dans les Listes des Pièces Détachées de ce manuel sont les pièces détachées recommandées par la Wacker. Cela veut dire que ces pièces sont sujettes à usure dans des conditions de travail normales et peuvent nécessiter de l'entretien ou leur remplacement. Nous recommandons que vous disposiez d'un stock de ces pièces pour pouvoir satisfaire la demande d'entretien de cette machine. Le client doit décider lui-même de la quantité exacte de pièces de rechange qu'il disposera dans ses stocks.

Les numéros de ma machine son :



1. Typ
2. Version
3. Artikel-Nr.
4. Maschinen-Nr.

Table de conversion

Unité de volume	
1 ml	0.034 US fl.oz.
1 l	0.260 gal
Unité de longueur	
1 mm	0.039 in
1 m	3.280 ft
Poids	
1 kg	2.200 lbs
1 g	0.035 oz
Vitesse	
1 km/h	0.620 mph
Couple de serrage	
1 Nm	0.740 ft.lbs

Vibrationsplatte Kpl.
Vibratory plate cpl.
Plancha vibradora cpl.
Plaque vibrante cpl. 10

Vibrationsplatte Kpl.
Vibratory plate cpl.
Plancha vibradora cpl.
Plaque vibrante cpl. 14

Erreger Kpl.
Exciter cpl.
Excitador cpl.
Excitateur cpl. 16

Fliehkraftkupplung
Centrifugal clutch
Embrague centrifugo
Embrayage centrifuge 18

Bügel Kpl.
Shackle cpl.
Estribo cpl.
Étrier cpl. 20

Aufkleber
Label
Calcomania
Autocollant 22

Motor
Engine
Motor
Moteur

Kurbelgehäuse
Crankcase
Cárter
Carter 24

Kurbelwelle
Crankshaft
Cigueñal
Vilebrequin 28

Nockenwelle
Camshaft
Arbol de levas
Arbre à cames 30

Kolben, Pleuel, Zylinder
Piston, connecting rod, cylind
Pistón, biela, cilindro
Piston, bielle, cylindre 32

Zylinderkopf
Cylinder head
Culata
Culasse 34



Ölpumpe, Regler, Drehzahlverstellung Oil pump, governor, adjustment r.p.m. Bomba de aceite, regulador, ajuste del no de r.p.m. Pompe à huile, régulateur,	38
Steuerdeckel Command cover Tapa del mando Couvercle de commande	42
Gebläse, Schwungrad Blower, fly wheel Ventilador, volante Ventilateur, volant	46
Einspritzausrüstung Injection equipment Sistema inyectora Système d'injection	48
Reversierstarter Recoil starter Starter reversible Démarreur réversible	52
Luftführung Air ducting Conducción de aire Carter ventilation	54
Kurbelgehäuseentlüftung Crankcase breathing system Purgado de cárter Raccord fileté de purge	58
Kraftstoffsystem Fuel system Sistema de combustible Système d'essence	60
Luftfilter Air cleaner Filtro del aire Filtre à air	66
Abgasdämpfer Exhaust silencer Silenciador Silencieux	68
Drehzahlverstellung FürBowdenzug Governor bowden cable Regulador de revoluciones cable bowden Régulateur de régime câble	70
Motorausrüstung EPA Engine equipment epa Equipamiento de motor epa Equipement moteur epa	72

Ersatzteilsätze Spare parts kits Juegos de repuestos Jeu de pièces de rechange	74
---	----

Zubehör Accessories Accesorios Accessoires	76
---	----

Zubehör
Accessories
Accesorios
Accessoires

Gleitvorrichtung Kpl. PGV 1850 Urethane pad kit cpl. pgv 1850 Placa de deslizamiento cpl. pgv 1850 Jeu de tapis en polyuréthane	78
--	----

Schutzrahmen Kpl. Protective frame cpl. Placca de proteccón cpl. Cadre protection cpl.	80
--	----

Fahrgestell Kpl. Trolley cpl. Dispositivo de transporte cpl. Chassis cpl.	82
---	----

Fahrgestell Trolley Dispositivo de transporte Chassis	84
--	----

Arretierung Kpl. Lock cpl. Dispositivo de retención cpl. Dispositif d' arrêt cpl.	86
---	----

Berieselung Kpl. Spinkler system cpl. Systema de riego cpl. Installation d'arrosage cpl.	88
--	----

Handgriff Kpl. Handle complete Manija compl. Poignée compl.	90
---	----

Vibrationsplatte Kpl.
Vibratory plate cpl.
Plancha vibradora cpl.
Plaque vibrante cpl.

DPS1850H BASIC

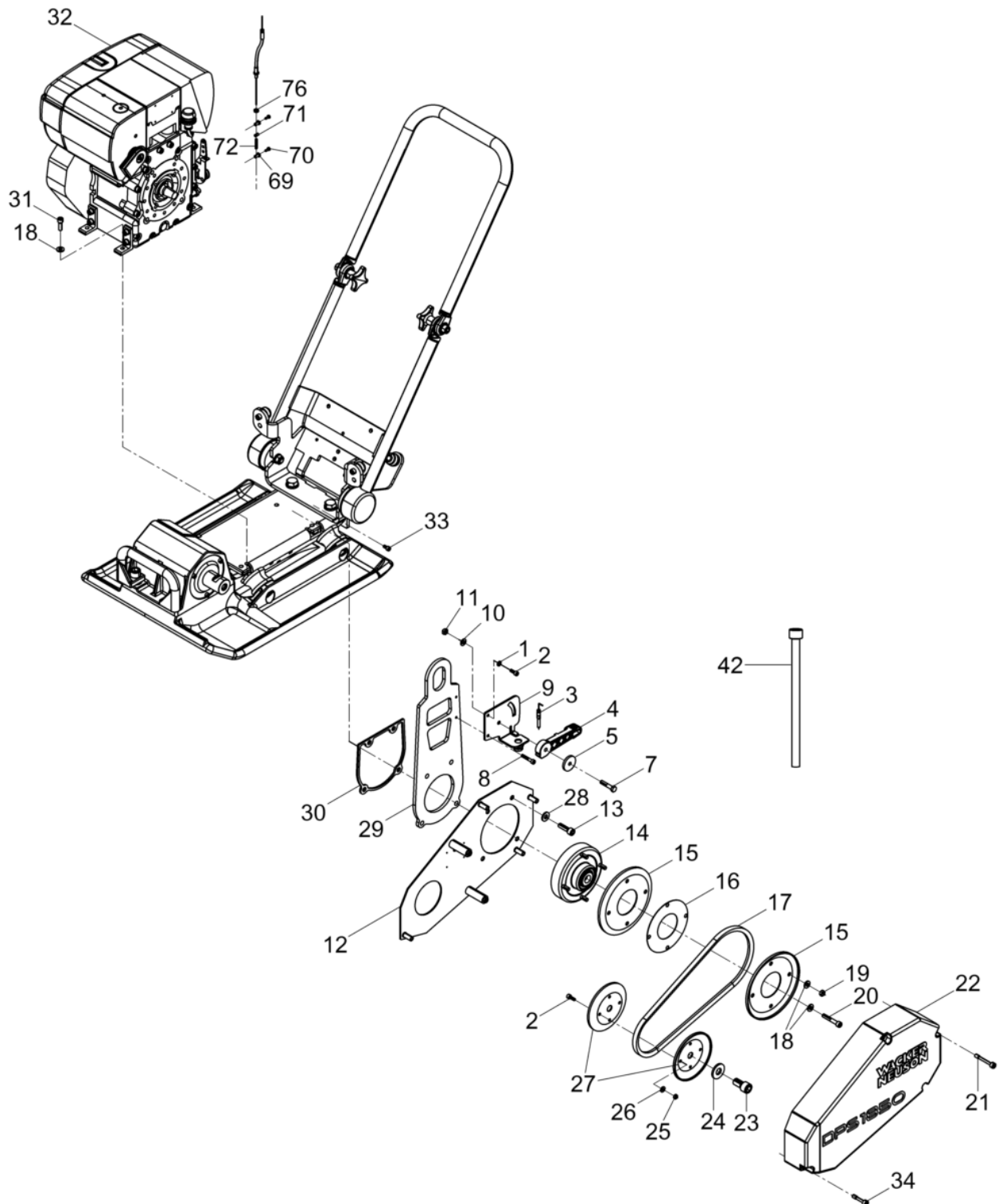

DPS1850H BASIC

Vibrationsplatte Kpl. Vibratory plate cpl. Plancha vibradora cpl. Plaque vibrante cpl.

Pos. Item	Artikel Nr. Item no.	Pc.	Unit	Beschreibung Descripción	Description Description	Abm. Dim.	Norm Standard
						Drehmoment Torque	Schmierstoff Lubricant
1	5000010624	1	pc	Scheibe Arandela	Flat washer Rondelle		
2	5000011553	5	pc	Zylinderschraube Tornillo cilíndrico	Cheese head screw Vis à tête cylindrique	10Nm/7ft.lbs	
3	5000125809	1	pc	Bowdenzug Cable bowden	Bowden cable Câble bowden		
4	5000203537	1	pc	Regulierhebel Palanca reguladora	Governor lever Levier régulateur		
5	5000205366	1	pc	Scheibe Arandela	Washer Rondelle		
7	5000011341	1	pc	Sechskantschraube Tornillo hexagonal	Hexagonal head cap screw Vis à tête hexagonale	M8 x 40 25Nm/18ft.lbs	DIN931
8	5000011548	1	pc	Zylinderschraube Tornillo cilíndrico	Cheese head screw Vis à tête cylindrique	10Nm/7ft.lbs	
9	5100052033	1	pc	Widerlager Cojinete	Bearing Roulement		
10	5000033198	1	pc	Spannscheibe Arandela elástica	Lockwasher Rondelle de ressort	8	DIN6796
11	5000033356	1	pc	Sechskantmutter Tuerca hexagonal	Hexagon nut Écrou hexagonal		
12	5000216662	1	pc	Befestigungsblech Kpl. Chapa de sujeción cpl.	Fixing plate cpl. Tôle de fixation cpl.		
13	5000011533	4	pc	Zylinderschraube Tornillo cilíndrico	Cheese head screw Vis à tête cylindrique	M10 x 35 49Nm/36ft.lbs	ISO4762
14	5000108162	1	pc	Fliehkraftkupplung Embrague centrifugo	Centrifugal clutch Embrayage centrifuge		
15	5000047280	2	pc	Keilriemenscheibenhälfte Semi-polea en v	V-belt pulley half Flanc de poulie à courroie		
16	5000047282	3	pc	Distanzscheibe Distanciator	Distance washer Disque d'écartement	X- 5000084441	
17	5000099941	1	pc	Schmalkeilriemen Correa en v angosta	Narrow v-belt Trapezoidale étroite		
18	5000033198	9	pc	Spannscheibe Arandela elástica	Lockwasher Rondelle de ressort	8	DIN6796
19	5000010882	4	pc	Sechskantmutter Tuerca hexagonal	Hexagon nut Écrou hexagonal		
20	5000011537	1	pc	Zylinderschraube Tornillo cilíndrico	Cheese head screw Vis à tête cylindrique	M8 x 50 25Nm/18ft.lbs	ISO4762
21	5000216659	3	pc	Dünnschaftschraube Tornillo	Screw Vis	M 8x 55 25Nm/18ft.lbs	
22	5000216661	1	pc	Riemenschutz Protección de la polea	Belt guard Protection de courroie		
23	5000044634	1	pc	Zylinderschraube Tornillo cilíndrico	Cheese head screw Vis à tête cylindrique	M16 x 30 295Nm/218ft.lbs	ISO4762
24	5000043353	1	pc	Spannscheibe Arandela elástica	Lockwasher Rondelle de ressort	16	DIN6796
25	5000010880	5	pc	Sechskantmutter Tuerca hexagonal	Hexagon nut Écrou hexagonal		
26	5000058381	4	pc	Spannscheibe Arandela elástica	Lockwasher Rondelle de ressort	6	DIN6796
27	5000099828	2	pc	Keilriemenscheibenhälfte Semi-polea en v	V-belt pulley half Flanc de poulie à courroie		
28	5000033988	4	pc	Spannscheibe Arandela elástica	Lockwasher Rondelle de ressort	10	DIN6796
29	5000201565	1	pc	Aufhängung Punto para itar	Lifting point Suspension		



Vibrationsplatte Kpl.
Vibratory plate cpl.
Plancha vibradora cpl.
Plaque vibrante cpl.

DPS1850H BASIC

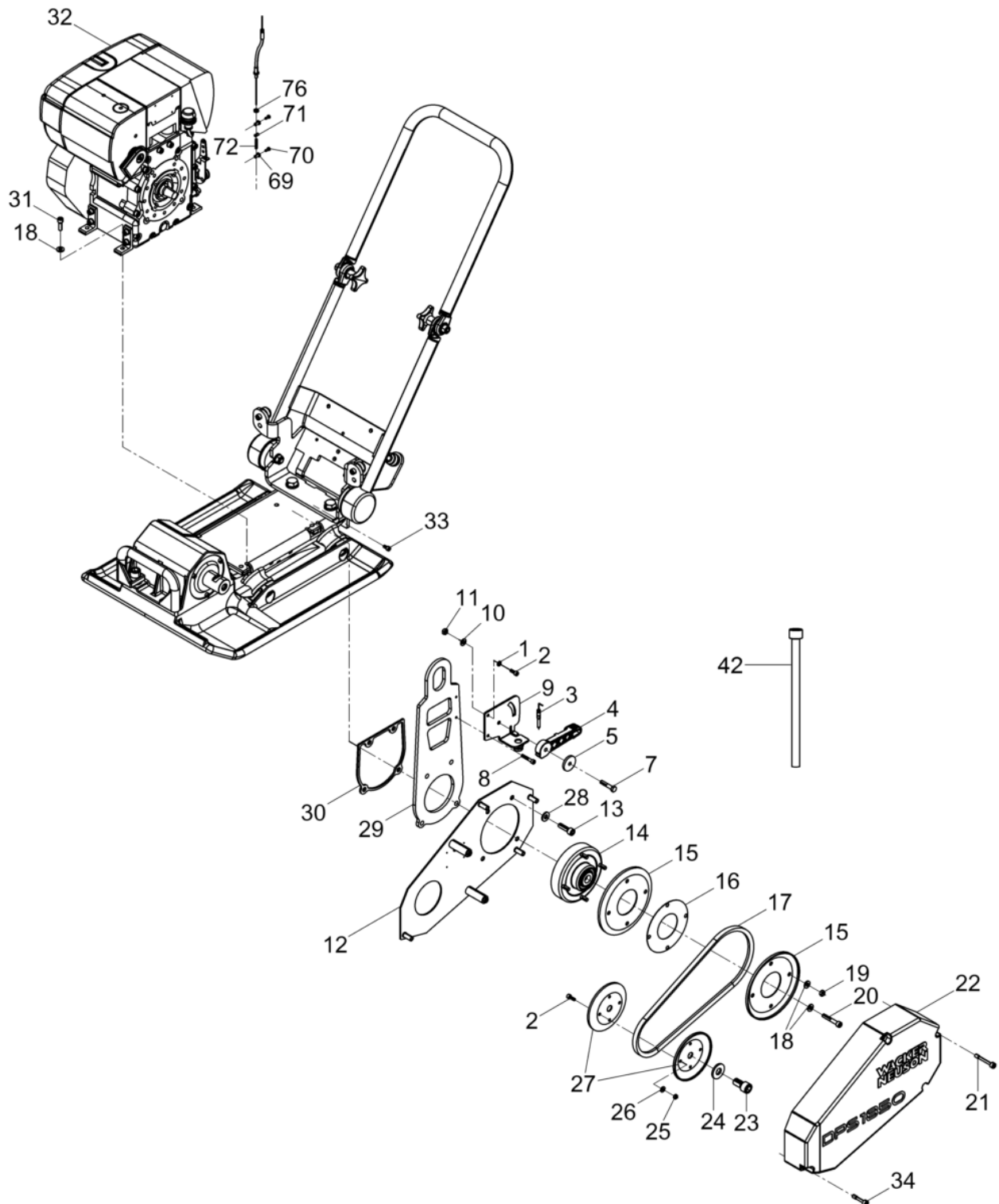

DPS1850H BASIC

Vibrationsplatte Kpl.
Vibratory plate cpl.
Plancha vibradora cpl.
Plaque vibrante cpl.

Pos. Item	Artikel Nr. Item no.	Pc.	Unit	Beschreibung Descripción	Description Description	Abm. Dim.	Norm Standard
						Drehmoment Torque	Schmierstoff Lubricant
30	5000108275	1	pc	Zwischenstück Pieza intermedia	Adaptor Pièce intermédiaire		
31	5000011542	4	pc	Zylinderschraube Tornillo cilíndrico	Cheese head screw Vis à tête cylindrique	25Nm/18ft.lbs	
32	5100043170	1	pc	Dieselmotor Motor diesel	Diesel engine Moteur diesel		
33	5000011554	1	pc	Zylinderschraube Tornillo cilíndrico	Cheese head screw Vis à tête cylindrique	10Nm/7ft.lbs	
34	5000216658	1	pc	Dünnschaftschraube Tornillo	Screw Vis	M 8x 38	
42	5000097318	1	pc	Ablaufstutzen Empalme	Adapter Raccord		
69	5000212532	2	pc	Schraubnippel Boquilla roscada	Screw nipple Raccord de vissage		
70	5000124429	2	pc	Sechskantschraube Tornillo hexagonal	Hexagonal head cap screw Vis à tête hexagonale	M4 x 10	DIN933
71	5000212531	1	pc	Schraubnippel Boquilla roscada	Screw nipple Raccord de vissage		
72	5000212534	1	pc	Druckfeder Resorte de compresión	Compression spring Ressort de pression	1 x 4 x 33 x 19,5	
75	5000010880	1	pc	Sechskantmutter Tuerca hexagonal	Hexagon nut Écrou hexagonal		



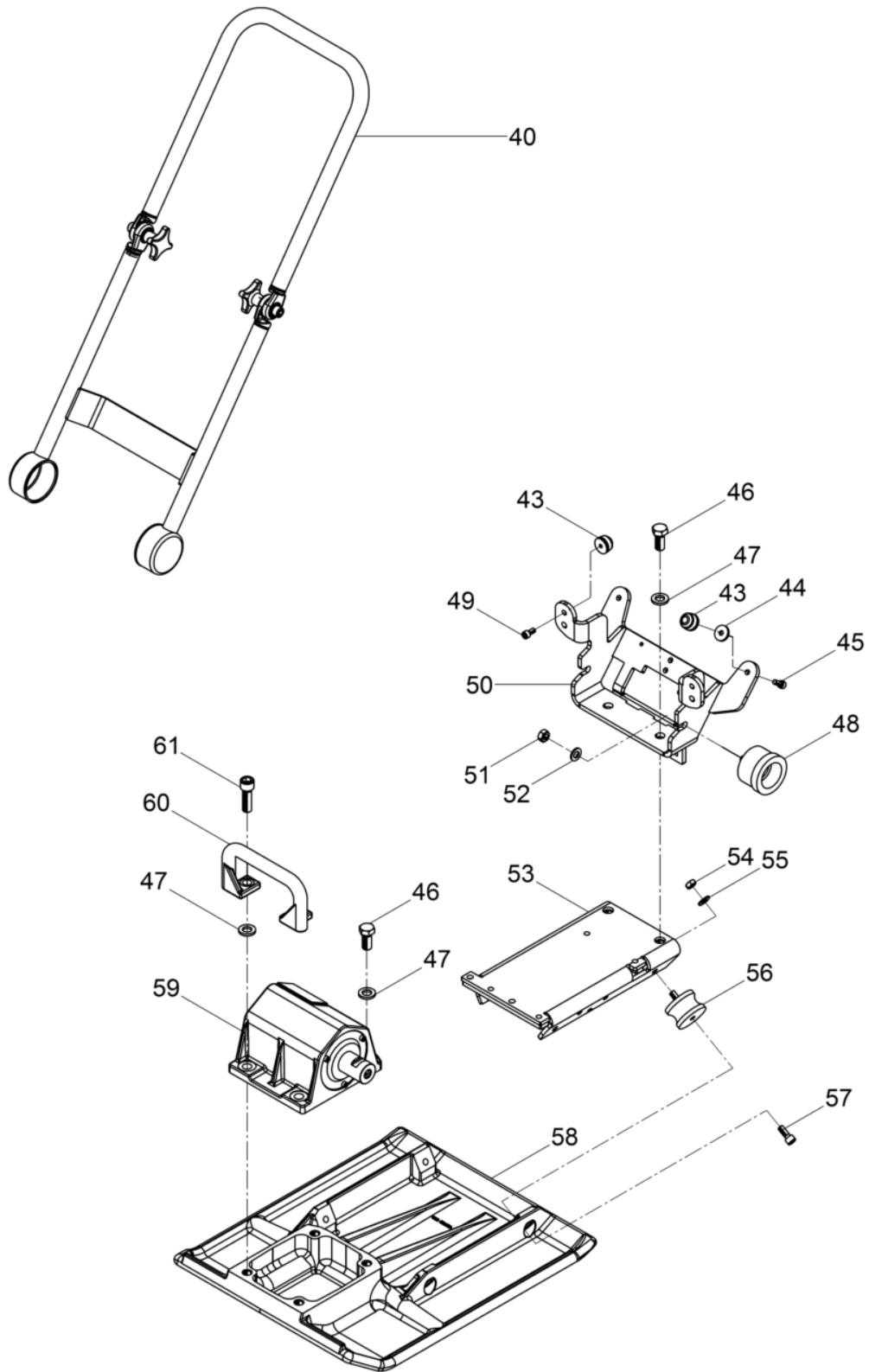

DPS1850H BASIC

Vibrationsplatte Kpl. Vibratory plate cpl. Plancha vibradora cpl. Plaque vibrante cpl.

Pos. Item	Artikel Nr. Item no.	Pc.	Unit	Beschreibung Descripción	Description Description	Abm. Dim.	Norm Standard
						Drehmoment Torque	Schmierstoff Lubricant
40	5000108269	1	pc	Bügel Kpl. Estribo cpl.	Shackle cpl. Étrier cpl.		
43	5000105056	4	pc	Anschlagpuffer Amortiguador	Shockmount Silentbloc	M30 x 20	
44	5000031632	2	pc	Scheibe Arandela	Washer Rondelle		
45	5000011543	2	pc	Zylinderschraube Tornillo hueco	Socket head screw Vis à six-pans creux	M8 x 20 25Nm/18ft.lbs	ISO4762
46	5000011522	4	pc	Sechskantschraube Tornillo hexagonal	Hexagonal head cap screw Vis à tête hexagonale	M16 x 35 210Nm/155ft.lbs	DIN933
47	5000021988	6	pc	Sicherungsscheibe Arandela de seguridad	Lock washer Rondelle d'arrêt	HS16	
48	5000106557	2	pc	Gummi-Metall-Puffer Tope caucho-metal	Shockmount Tampon métallique oscillant		
49	5000011544	2	pc	Zylinderschraube Tornillo cilíndrico	Cheese head screw Vis à tête cylindrique	M8 x 16 25Nm/18ft.lbs	ISO4762
50	5000201824	1	pc	Deichselkonsole Consola de barra de mando	Center pole console Console de timon		
51	5000010884	2	pc	Sechskantmutter Tuerca hexagonal	Hexagon nut Écrou hexagonal	M12	DIN934
52	5000010620	2	pc	Scheibe Arandela	Flat washer Rondelle	12	ISO7090
53	5000201558	1	pc	Motorkonsole Conjunto soporte de motor	Engine mount assembly Montage du moteur		
54	5000010883	4	pc	Sechskantmutter Tuerca hexagonal	Hexagon nut Écrou hexagonal		
55	5000033988	4	pc	Spannscheibe Arandela elástica	Lockwasher Rondelle de ressort	10	DIN6796
56	5000037378	4	pc	Gummi-Metall-Kerbpuffer Tope caucho-metal	Shockmount Tampon métallique oscillant	60 x 40	
57	5000011535	4	pc	Zylinderschraube Tornillo cilíndrico	Cheese head screw Vis à tête cylindrique	49Nm/36ft.lbs	
58	5000069882	1	pc	Grundplatte Placa base	Base plate Plaque de base		
59	5000105405	1	pc	Erreger Kpl. Excitador cpl.	Exciter cpl. Vibrateur cpl.		
60	5000126072	1	pc	Griff Empuñadura	Handle Poignée		
61	5000127056	2	pc	Zylinderschraube Tornillo cilíndrico	Cheese head screw Vis à tête cylindrique	M16 x 50 210Nm/155ft.lbs	ISO4762



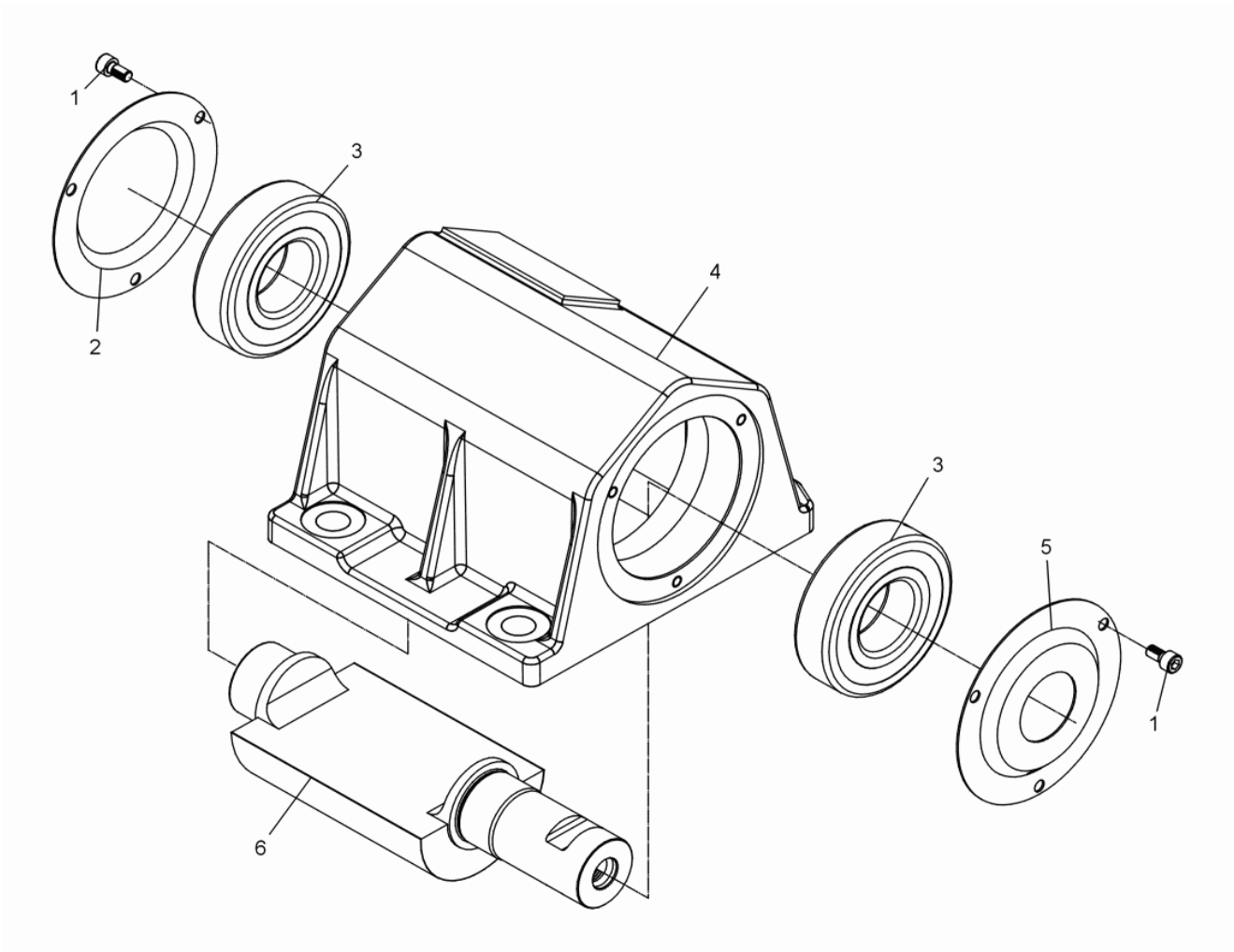

DPS1850H BASIC**Erreger Kpl.
Exciter cpl.
Excitador cpl.
Excitateur cpl.**

Pos. Item	Artikel Nr. Item no.	Pc.	Unit	Beschreibung Descripción	Description Description	Abm. Dim.	Norm Standard
						Drehmoment Torque	Schmierstoff Lubricant
1	5000011554	6	pc	Zylinderschraube Tornillo cilíndrico	Cheese head screw Vis à tête cylindrique	10Nm/7ft.lbs	
2	5000099826	1	pc	Deckel Tapa	Cover Couvercle		
3	5000099871	2	pc	Rillenkugellager Rodamiento a bolas	Grooved ball bearing Roulement rainuré à billes		
4	5000099824	1	pc	Erregergehäuse Carcasa del excitador	Exciter housing Carter excitateur		
5	5000099825	1	pc	Deckel Tapa	Cover Couvercle		
6	5000105404	1	pc	Unwuchtwelle Eje de la masa excéntrica	Eccentric shaft Arbre portant l'excentrique		



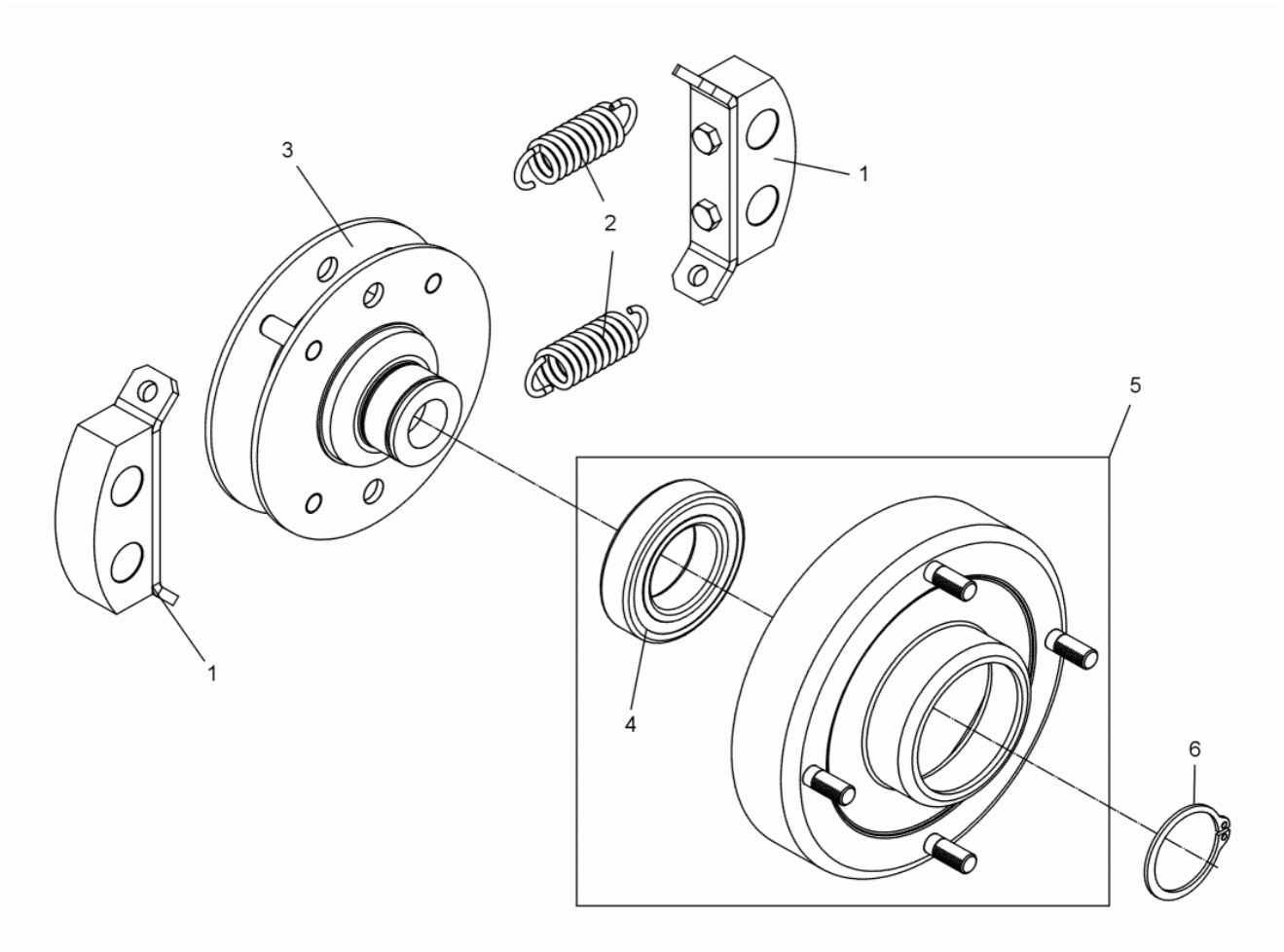

DPS1850H BASIC**Fliehkraftkupplung
Centrifugal clutch
Embrague centrifugo
Embrayage centrifuge**

Pos. Item	Artikel Nr. Item no.	Pc.	Unit	Beschreibung Descripción	Description Description	Abm. Dim.	Norm Standard
						Drehmoment Torque	Schmierstoff Lubricant
1	5000045716	2	pc	Reibklotz Kpl. Taco frotante cpl.	Friction block cpl. Bloc frottant cpl.		
2	5000058765	2	pc	Zugfeder Resorte de tracción	Tension spring Ressort de traction		
3	5000108161	1	pc	Nabe Kpl. Cubo cpl.	Hub cpl. Moyeu cpl.		
4	5000022625	1	pc	Rillenkugellager Rodamiento a bolas	Grooved ball bearing Roulement rainuré à billes		
5	5000106622	1	pc	Trommel Kpl. Tambor cpl.	Drum cpl. Tambour cpl.		
6	5002003022	1	pc	Sicherungsring Anillo de retención	Retaining ring Bague d'arrêt	35 x 1,5	DIN471



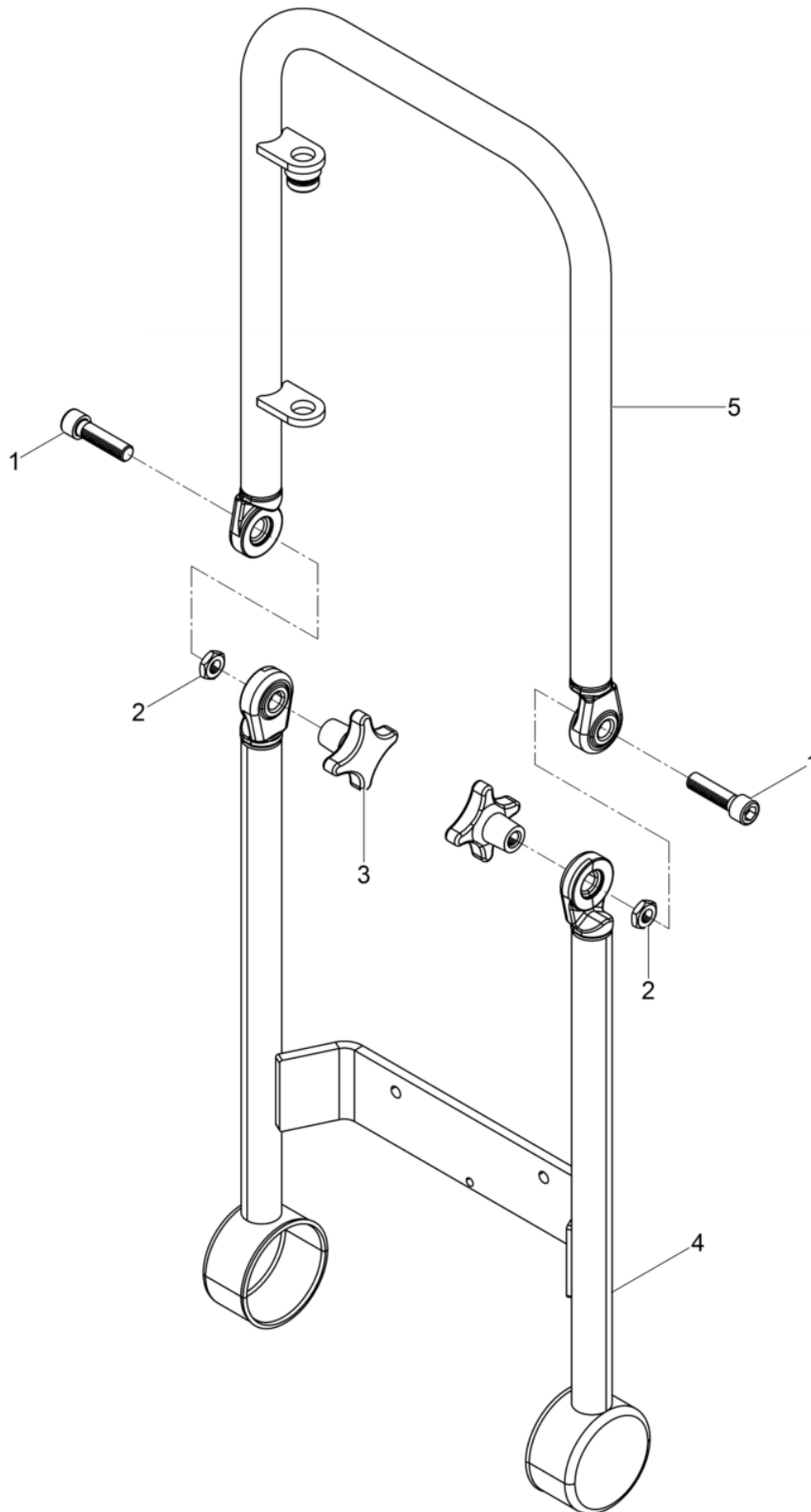

DPS1850H BASIC**Bügel Kpl.
Shackle cpl.
Estribo cpl.
Étrier cpl.**

Pos. Item	Artikel Nr. Item no.	Pc.	Unit	Beschreibung Descripción	Description Description	Abm. Dim.	Norm Standard
						Drehmoment Torque	Schmierstoff Lubricant
1	5000011526	2	pc	Zylinderschraube Tornillo cilíndrico	Cheese head screw Vis à tête cylindrique	M12 x 45 86Nm/63ft.lbs	ISO4762
2	5000033349	2	pc	Sechskantmutter Tuerca hexagonal	Hexagon nut Écrou hexagonal	M12	DIN439
3	5000097454	2	pc	Kreuzgriff Empuñadura	Star-handle Poignée étoile		
4	5000108267	1	pc	Bügel Unten Estribo	Shackle Étrier		
5	5000108268	1	pc	Bügel Oben Estribo	Shackle Étrier		



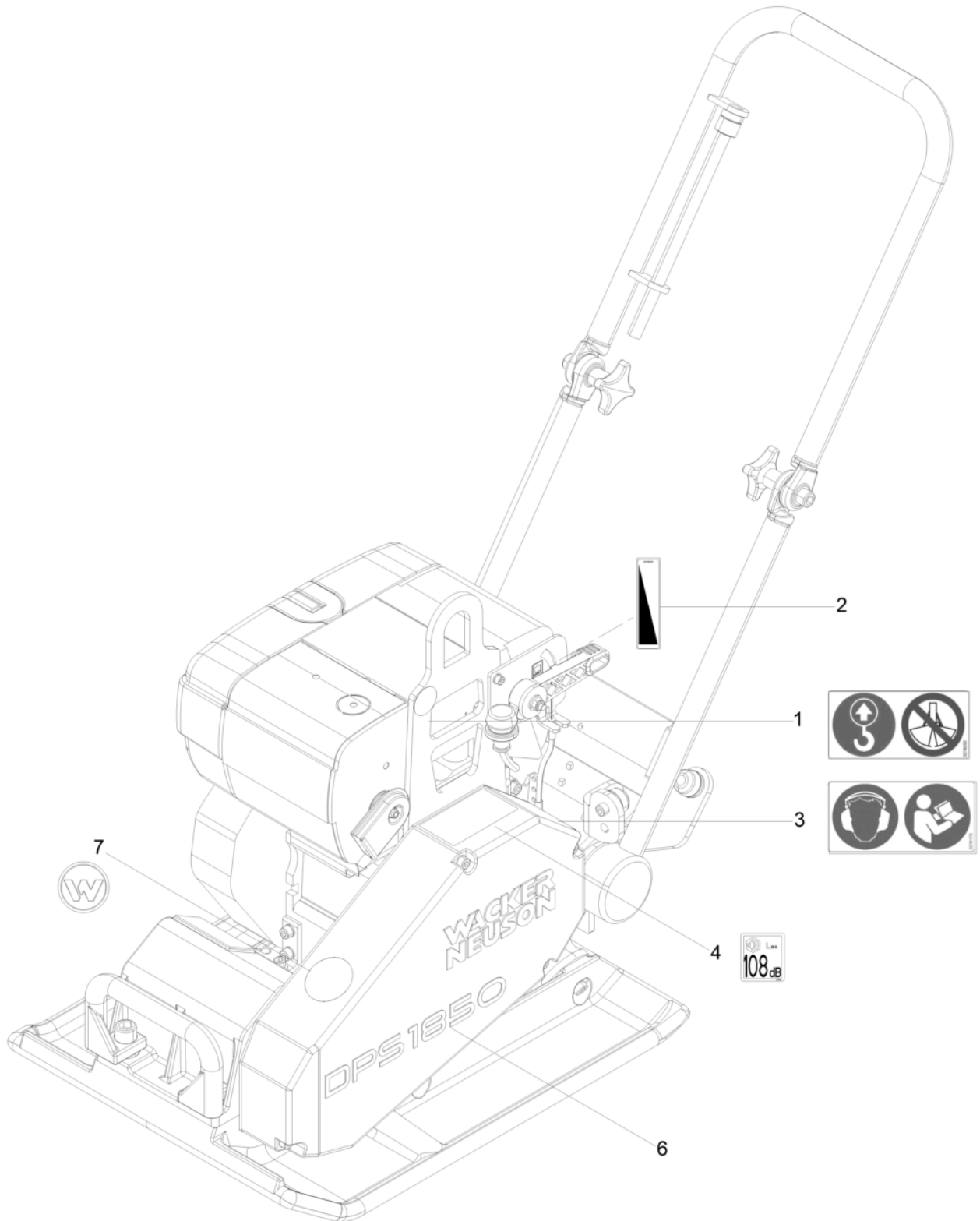

Pos. Item	Artikel Nr. Item no.	Pc.	Unit	Beschreibung Descripción	Description Description	Abm. Dim.	Norm Standard
						Drehmoment Torque	Schmierstoff Lubricant
1	5000219260	1	pc	Aufkleber Calcomanias	Labels Autocollants		
2	5000219259	1	pc	Aufkleber Calcomanias	Labels Autocollants		
3	5000219175	1	pc	Aufkleber Calcomanias	Labels Autocollants		
4	5000129784	1	pc	Aufkleber-Schalleistungspegel Etiqueta autoadhesiva-nivel de potencia acúëstica	Decal-sound power level Autocollante-niveau sonore		
6	5000108285	1	pc	Aufkleber-Typ Tipo etiqueta autoadhesiva	Type label Autocollant de type		
7	5000222085	1	pc	Aufkleber Symbol Calcomania símbolo	Label symbol Autocollant symbole		

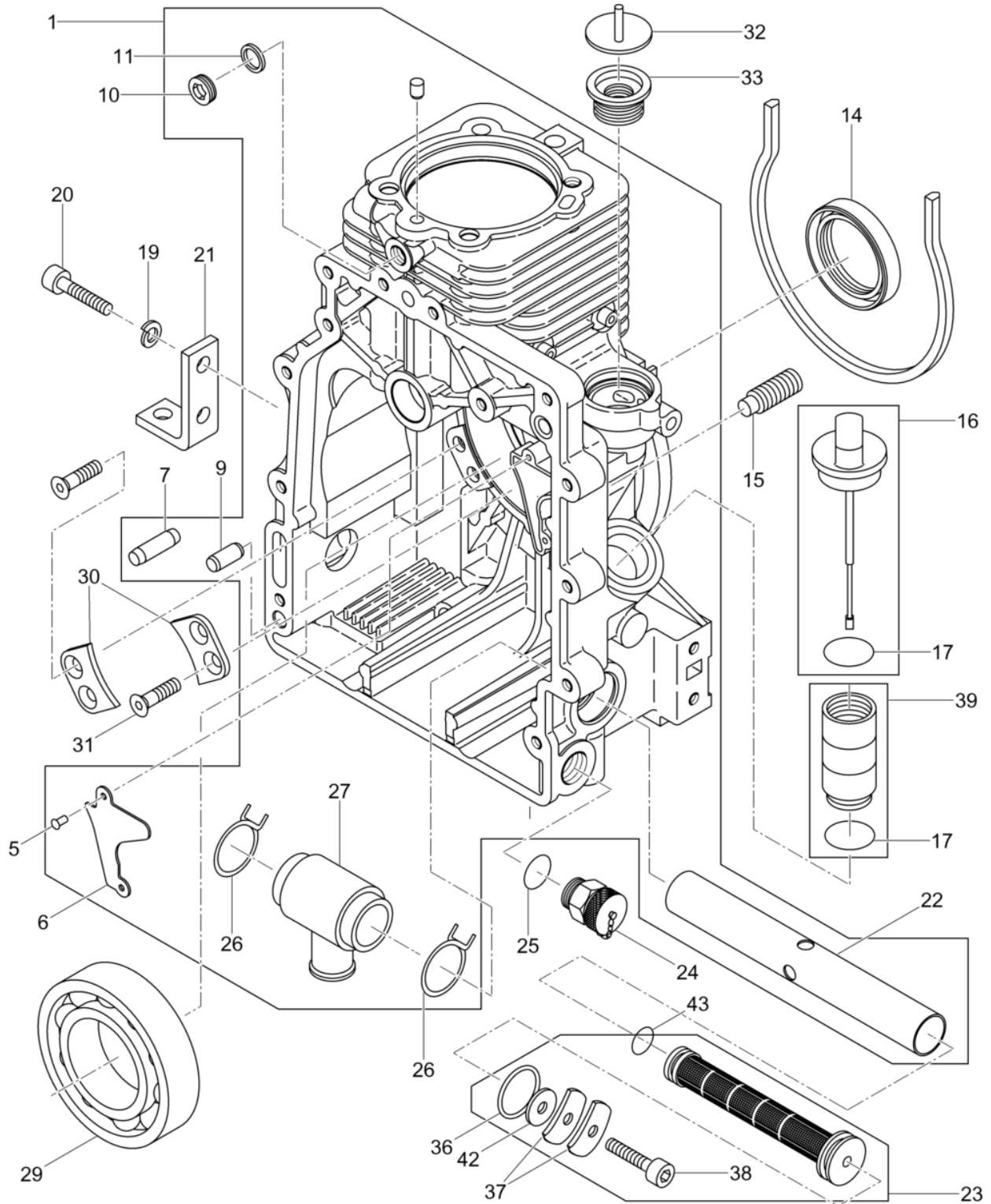

Pos. Item	Artikel Nr. Item no.	Pc.	Unit	Beschreibung Descripción	Description Description	Abm. Dim.	Norm Standard
						Drehmoment Torque	Schmierstoff Lubricant
1	5000129029	1	pc	Kurbelgehäuse Cárter	Crankcase Carter		
5	5100038898	2	pc	Blindniet 3,2X7 Remache ciego	Blind rivet Rivet dobturation		
6	5100017212	1	pc	Deckel Tapa	Cover Couvercle		
7	5000108694	1	pc	Zylinderstift Pasador cilíndrico	Straight pin Goupille cylindrique	8m6 x 20	DIN6325
9	5000108694	1	pc	Zylinderstift Pasador cilíndrico	Straight pin Goupille cylindrique	8m6 x 20	DIN6325
10	5000071121	1	pc	Dichtungsring Anillo sellante	Sealing ring Bague d'étanchéité	A10 x 13,5	
11	5000151213	1	pc	Verschlusschraube Tornillo de cierre	Screw plug Vis de fermeture	M10 X 1	DIN908
14	5000108679	1	pc	Wellendichtring Empaque de aceite	Oil seal Joint d'huile	40 x 55 x 10	
15	5100051930	1	pc	Gewindestift Varilla roscada	Threaded pin Goupille fileté		
16	5000128995	1	pc	Tauchstab Varilla de inmersión	Dipstick Jauge		
17	5000151217	1	pc	Wellendichtring Anillo de sellado	Gasket Anneau d'étanchéité	26x35x3	
19	5000151218	8	pc	Federring Arandela elástica	Lock washer Rondelle de ressort	8	
20	5000108683	8	pc	Schraube Tornillo	Screw Vis	M8 x 35	
21	5000108682	4	pc	Motorfuß Soporte	Bracket Support		
22	5000151221	1	pc	Ölfiltergehäuse Caja	Housing Carter		
23	5000108685	1	pc	Ölfilter Filtro de aceite	Oil filter Filtre d'huile		
24	5100051907	1	pc	Ölablassventil Válvula de purgado	Oil drain valve Soupape découlement dhuile		
25	5000202416	1	pc	Öldichtung Junta de aceite	Oil seal Joint d'huile	52 x 80 x 10	
26	5000108688	2	pc	Schlauchklemme Sujetador	Clip Agrafe		
27	5100051929	1	pc	T-Stück Pieza t	T-piece T-pièce		
29	5000108690	1	pc	Lager Rodamiento	Bearing Roulement	6308	
30	5000108692	2	pc	Halter Placa	Plate Plaque		
31	5000209740	4	pc	Senkkopfschraube Tornillo avellanado	Countersunk screw Vis noyée	M6x16	
32	5000108676	1	pc	Scheibe Arandela	Washer Rondelle		
33	5100032125	1	pc	Membran Diafragma	Diaphragm Diaphragme		
36	5000151229	1	pc	O-Ring Anillo-o	O-ring Joint torique	20 x 4	
37	5000151230	2	pc	Ölfilterfeder Resorte de filtro de aceite	Oil filter spring Clavette filtre à huile		
38	5000151231	1	pc	Zylinderschraube Tornillo cilíndrico	Cheese head screw Vis à tête cylindrique	M6 x 16	ISO4762

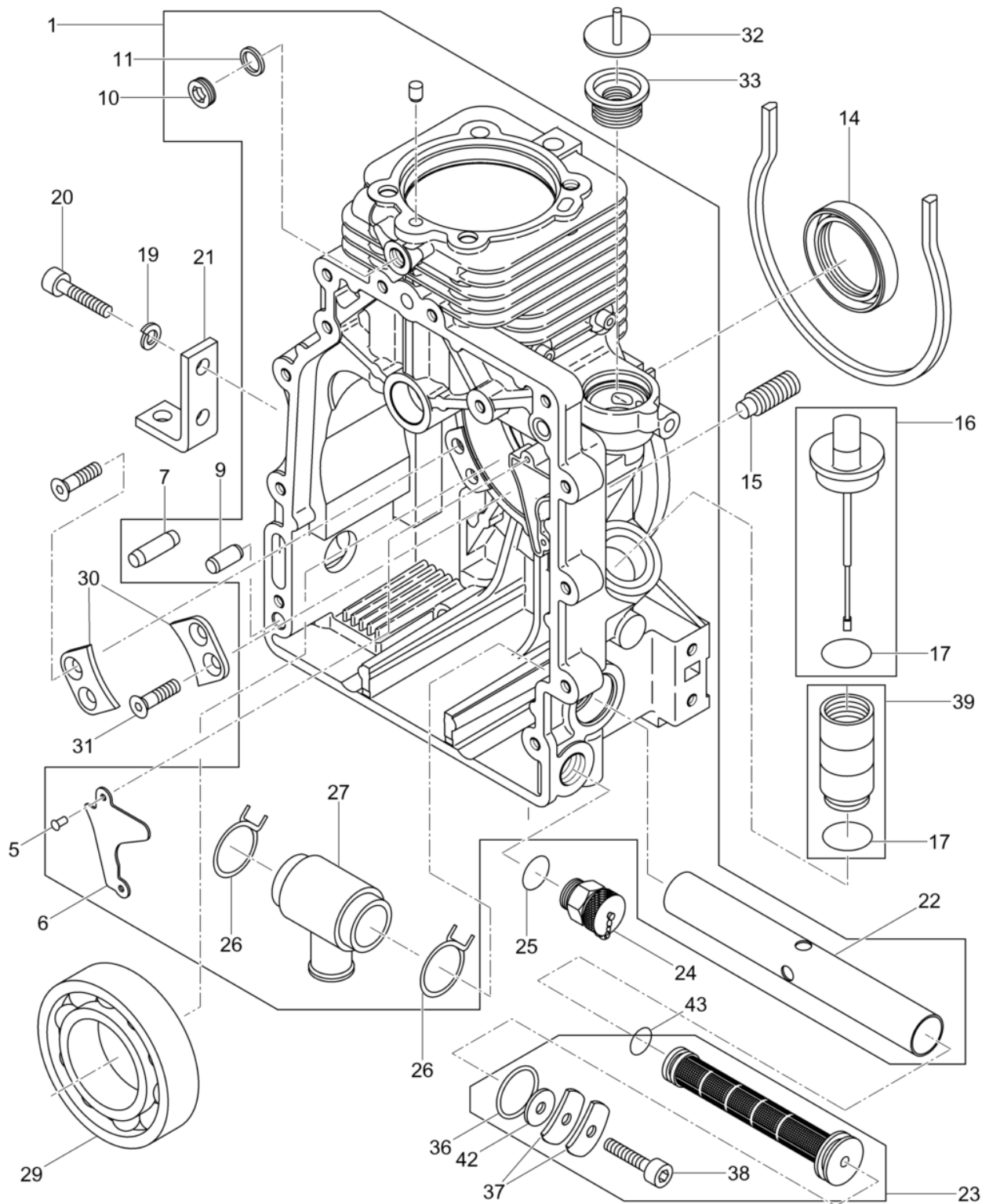

Pos. Item	Artikel Nr. Item no.	Pc.	Unit	Beschreibung Descripción	Description Description	Abm. Dim.	Norm Standard
						Drehmoment Torque	Schmierstoff Lubricant
39	5000129023	1	pc	Verlängerung Öleinfüllstutzen Extensión boca de llenado de aceite	Extension oil filler neck Extension tubulure de		
42	5000108851	1	pc	Scheibe Arandela	Washer Rondelle	6,5 x 22,5 x 1	
43	5100053372	1	pc	O-Ring Anillo-o	O-ring Bague-o		

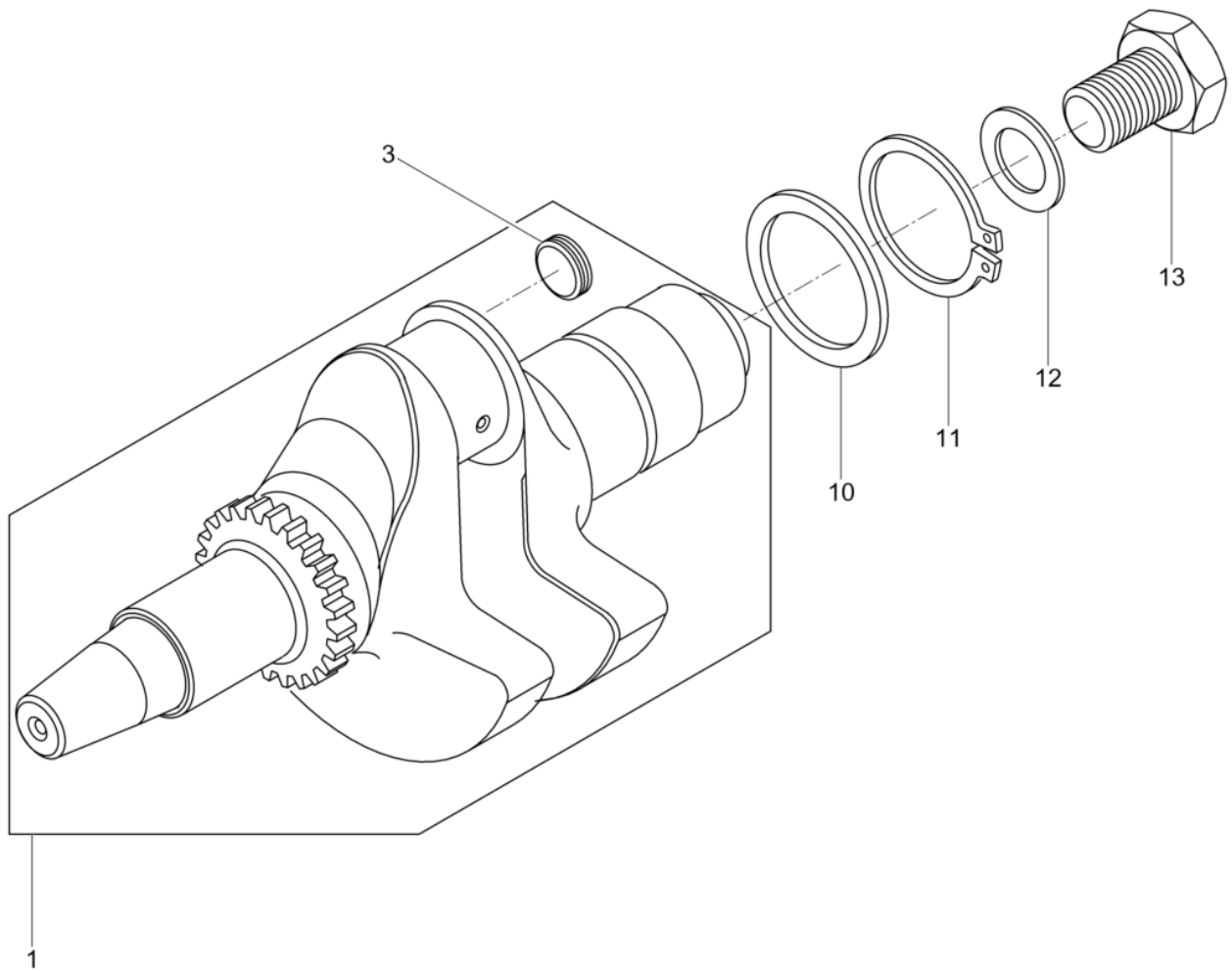

DPS1850H BASIC**Kurbelwelle
Crankshaft
Cigüeñal
Vilebrequin**

Pos. Item	Artikel Nr. Item no.	Pc.	Unit	Beschreibung Descripción	Description Description	Abm. Dim.	Norm Standard
						Drehmoment Torque	Schmierstoff Lubricant
1	5000215771	1	pc	Kurbelwelle Cigüeñal	Crankshaft Vilebrequin		
3	5100016524	1	pc	Deckel Tapa	Cover Couvercle		
10	5000108714	1	pc	Stützscheibe Arandela de soporte	Supporting washer Disque d'appui		
11	5000129514	1	pc	Sicherungsring Anillo de retención	Retaining ring Bague d'arrêt	40 x 1,75	
12	5000108715	1	pc	Scheibe Disco	Disc Disque	18,5 x 37 x 5	
13	5100051911	1	pc	Sechskantschraube Tornillo hexagonal	Hexagonal head cap screw Vis à tête hexagonale		



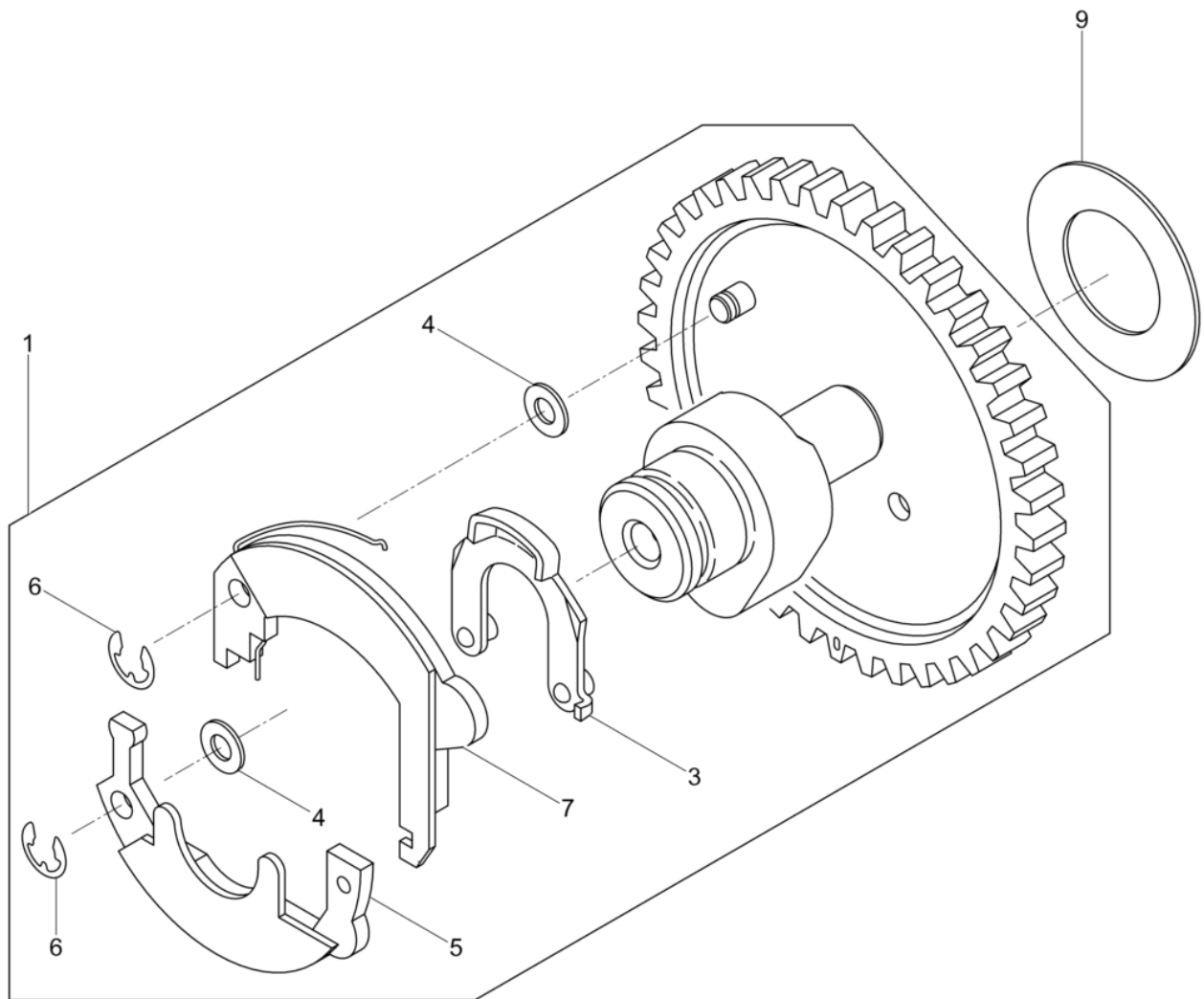

Pos. Item	Artikel Nr. Item no.	Pc.	Unit	Beschreibung Descripción	Description Description	Abm. Dim.	Norm Standard
						Drehmoment Torque	Schmierstoff Lubricant
1	5000151248	1	pc	Nockenwelle Arbol de levas	Camshaft Arbre à cames		
3	5000108707	1	pc	Bügel Palanca	Lever Levier		
4	5000108700	2	pc	Passscheibe Arandela de ajuste	Shim ring Disque d'ajustage	5 x 10 x 0,5	DIN988
5	5000108709	1	pc	Fliehgewicht Peso	Weight Poids		
6	5000151253	2	pc	Sicherungsscheibe Arandela de seguridad	Lock washer Rondelle d'arrêt	3,2	DIN6799
7	5000108708	1	pc	Fliehgewicht Peso centrifugo	Centrifugal weight Poids centrifuge		
9	5000108701	1	pc	Passscheibe Arandela de ajuste	Shim ring Disque dajustage	0,9	
9	5000108702	1	pc	Ausgleichsscheibe Laminilla	Shim Cale	1,0	
9	5000108703	1	pc	Ausgleichsscheibe Laminilla	Shim Cale	1,1	
9	5000108704	1	pc	Ausgleichsscheibe Laminilla	Shim Cale	1,2	
9	5000108705	1	pc	Passscheibe Arandela de ajuste	Shim ring Disque dajustage	1,3	
9	5000108706	1	pc	Passscheibe Arandela de ajuste	Shim ring Disque dajustage	1,4	

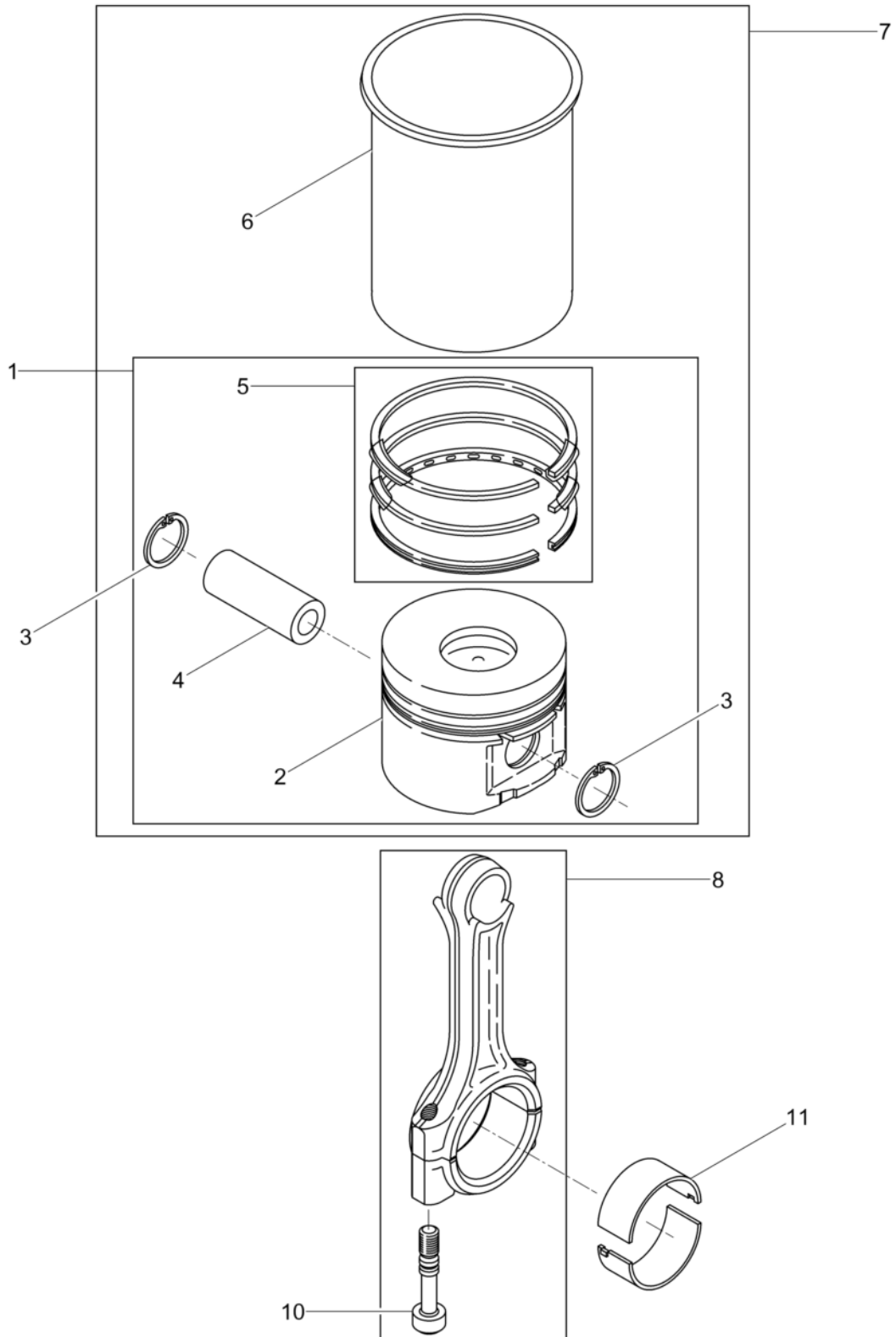

DPS1850H BASIC**Kolben, Pleuel, Zylinder
Piston, connecting rod, cylind
Pistón, biela, cilindro
Piston, bielle, cylindre**

Pos. Item	Artikel Nr. Item no.	Pc.	Unit	Beschreibung Descripción	Description Description	Abm. Dim.	Norm Standard
						Drehmoment Torque	Schmierstoff Lubricant
1	5000215769	1	pc	Kolben Kpl. Pistón cpl.	Piston cpl. Piston cpl.		
3	5000108722	2	pc	Sicherungsring Anillo de retención	Retaining ring Bague d'arrêt	18 x 1	DIN472
5	5000129030	1	pc	Kolbenringsatz Juego de aros de pistón	Set of piston rings Jeu de segments de piston	ø69 x 1,5	
7	5000215772	1	pc	Zylinder Mit Kolben Cilindro con pistón	Cylinder with piston Cylindre avec piston		
8	5100051953	1	pc	Pleuelstange Kpl. Biela cpl.	Connecting rod cpl. Bielle cpl.		
10	5000108720	2	pc	Pleuelschraube Tornillo	Screw Vis		
11	5000108717	1	pc	Pleuellager Rodamiento	Bearing Roulement		
11	5000108718	1	pc	Pleuellager Rodamiento	Bearing Roulement	-0,5	



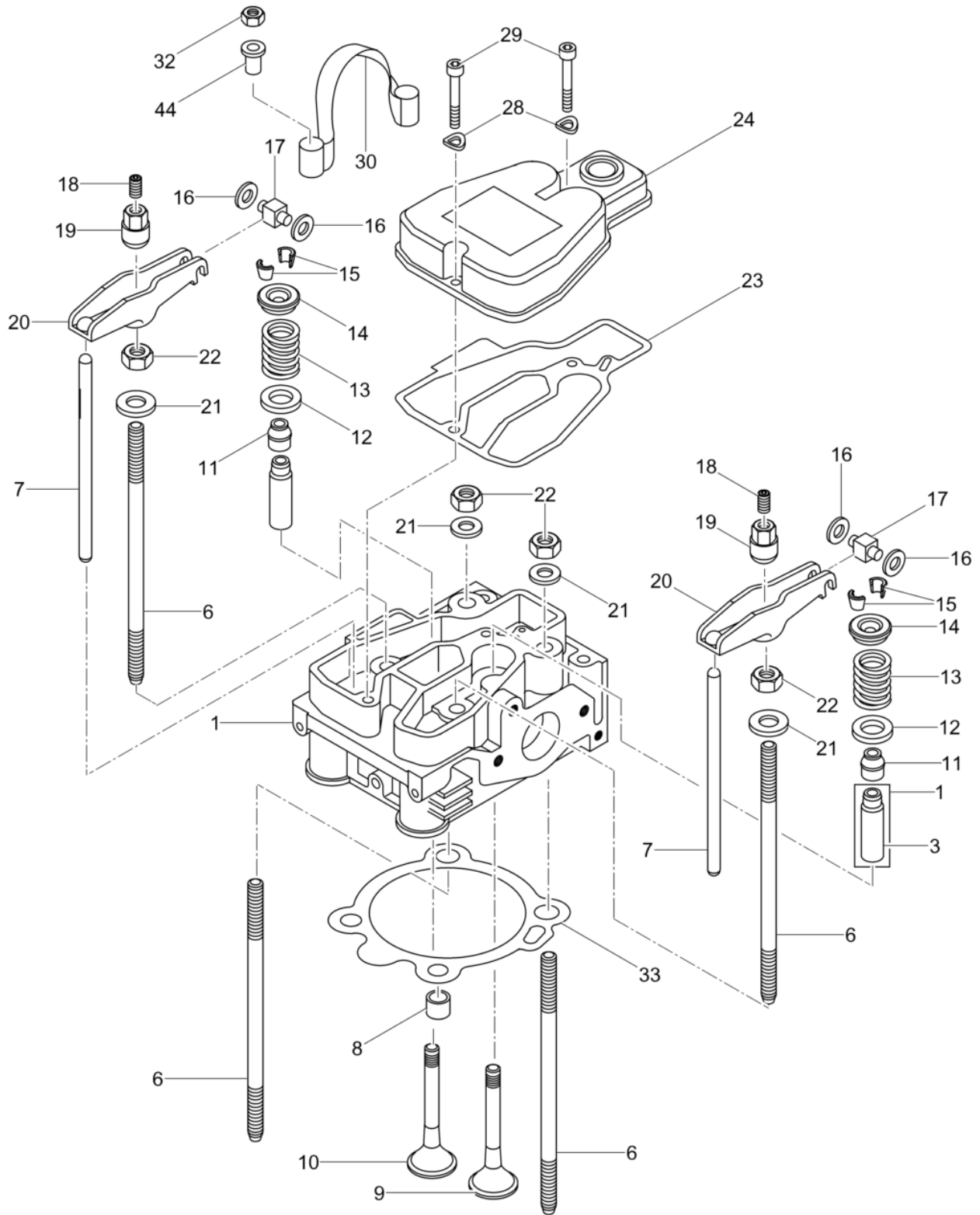

Pos. Item	Artikel Nr. Item no.	Pc.	Unit	Beschreibung Descripción	Description Description	Abm. Dim.	Norm Standard
						Drehmoment Torque	Schmierstoff Lubricant
1	5100051960	1	pc	Zylinderkopf Culata	Cylinder head Culasse		
3	5000129000	2	pc	Ventilführung Guía de válvula	Valve guide Guide de soupape		
6	5000108740	4	pc	Stiftschraube Perno prisionero	Stud Boulon	128M	
7	5000108741	2	pc	Stoßstange Levantaválvula	Push rod (valve lifter) Poussoir de soupape		
8	5000108752	2	pc	Dichtring Anillo de junta	Gasket Bague détanchéité		
9	5000108750	1	pc	Einlassventil Válvula de admisión	Intake valve Soupape d'admission		
10	5000108751	1	pc	Auslaßventil Válvula de escape	Exhaust valve Soupape d'échappement		
11	5100013781	2	pc	Dichtung Junta	Gasket Joint		
12	5100038980	2	pc	Scheibe Arandela	Washer Rondelle		
13	5000108736	2	pc	Ventilfeder Resorte	Spring Ressort		
14	5000108735	2	pc	Federteller Placa	Plate Plaque		
15	5000108734	2	pc	Ventilkonussatz Soporte	Spring holder Support		
16	5000108730	1	pc	Scheibe Disco	Disc Disque	6 x 12 x 1,2	
16	5000202301	1	pc	Scheibe Arandela	Washer Rondelle	6 x 12 x 1,35	
17	5000108731	2	pc	Rolle Manguito	Slider Douille		
18	5000129001	2	pc	Gewindestift Varilla roscada	Threaded pin Goupille fileté	M8 x 10	DIN916
19	5000108732	2	pc	Einstellmutter Tuerca	Nut Ecrou		
20	5000108733	2	pc	Kipphebel Balancín	Rocker arm Culbuteur		
21	5000108739	4	pc	Scheibe Arandela	Washer Rondelle	8,1 x 20 x 3	
22	5000094876	4	pc	Sechskantmutter Tuerca hexagonal	Hexagon nut Écrou hexagonal	M8	ISO4032
23	5000108729	1	pc	Dichtung Junta	Seal Joint		
24	5100051927	1	pc	Deckel Tapa	Cover Couvercle		
28	5000151290	2	pc	Federscheibe Arandela elástica	Spring washer Rondelle à ressort	A6	DIN137
29	5000129002	2	pc	Zylinderschraube Tornillo cilíndricoatado	Cheese head screw Vis à tête cylindrique	M6 x 35	ISO4762
30	5000209694	1	pc	Motoraufhängung Montaje del motor	Engine mount Montage du moteur		
32	5000129516	2	pc	Mutter Tuerca	Nut Ecrou	M8	
33	5000108742	1	pc	Dichtung Junta	Gasket Joint	0,3	
33	5000108743	1	pc	Dichtung Junta	Gasket Joint	0,4	

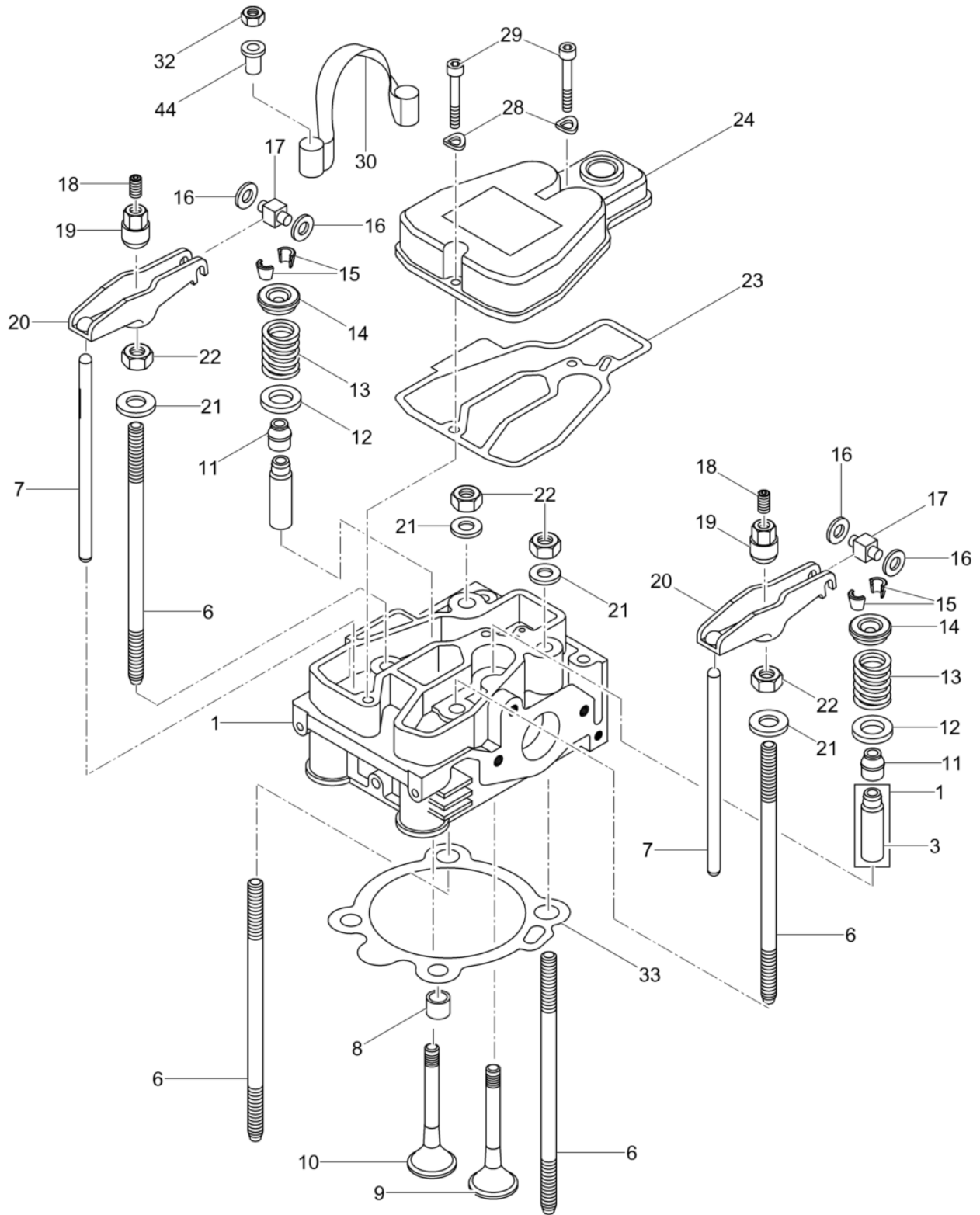

Pos. Item	Artikel Nr. Item no.	Pc.	Unit	Beschreibung Descripción	Description Description	Abm. Dim.	Norm Standard
						Drehmoment Torque	Schmierstoff Lubricant
33	5000108744	1	pc	Dichtung Junta	Gasket Joint	0,5	
33	5000108745	1	pc	Dichtung Junta	Gasket Joint	0,6	
33	5000108746	1	pc	Dichtung Junta	Gasket Joint	0,7	
33	5000108747	1	pc	Dichtung Junta	Gasket Joint	0,8	
33	5000108748	1	pc	Dichtung Junta	Gasket Joint	0,9	
33	5000108749	1	pc	Dichtung Junta	Gasket Joint	1,0	
33	5000209700	1	pc	Zylinderkopfdichtung Junta de culata del cilindro	Cylinder head gasket Joint de culasse de cylindre	0,35	
33	5000209701	1	pc	Zylinderkopfdichtung Junta de culata del cilindro	Cylinder head gasket Joint de culasse de cylindre	0,45	
33	5000209702	1	pc	Zylinderkopfdichtung Junta de culata del cilindro	Cylinder head gasket Joint de culasse de cylindre	0,55	
33	5000209703	1	pc	Zylinderkopfdichtung Junta de culata del cilindro	Cylinder head gasket Joint de culasse de cylindre	0,65	
33	5000209704	1	pc	Zylinderkopfdichtung Junta de culata del cilindro	Cylinder head gasket Joint de culasse de cylindre	0,75	
33	5000209705	1	pc	Zylinderkopfdichtung Junta de culata del cilindro	Cylinder head gasket Joint de culasse de cylindre	0,85	
33	5000209706	1	pc	Zylinderkopfdichtung Junta de culata del cilindro	Cylinder head gasket Joint de culasse de cylindre	0,95	
44	5000209736	2	pc	Rohrniet Inserto	Insert Insertion	A10x0,75x10	

Ölpumpe, Regler, Drehzahlverstellung
 Oil pump, governor, adjustment r.p.m.
 Bomba de aceite, regulador, ajuste del no de r.p.m.
 Pompe à huile, régulateur,

DPS185OH BASIC

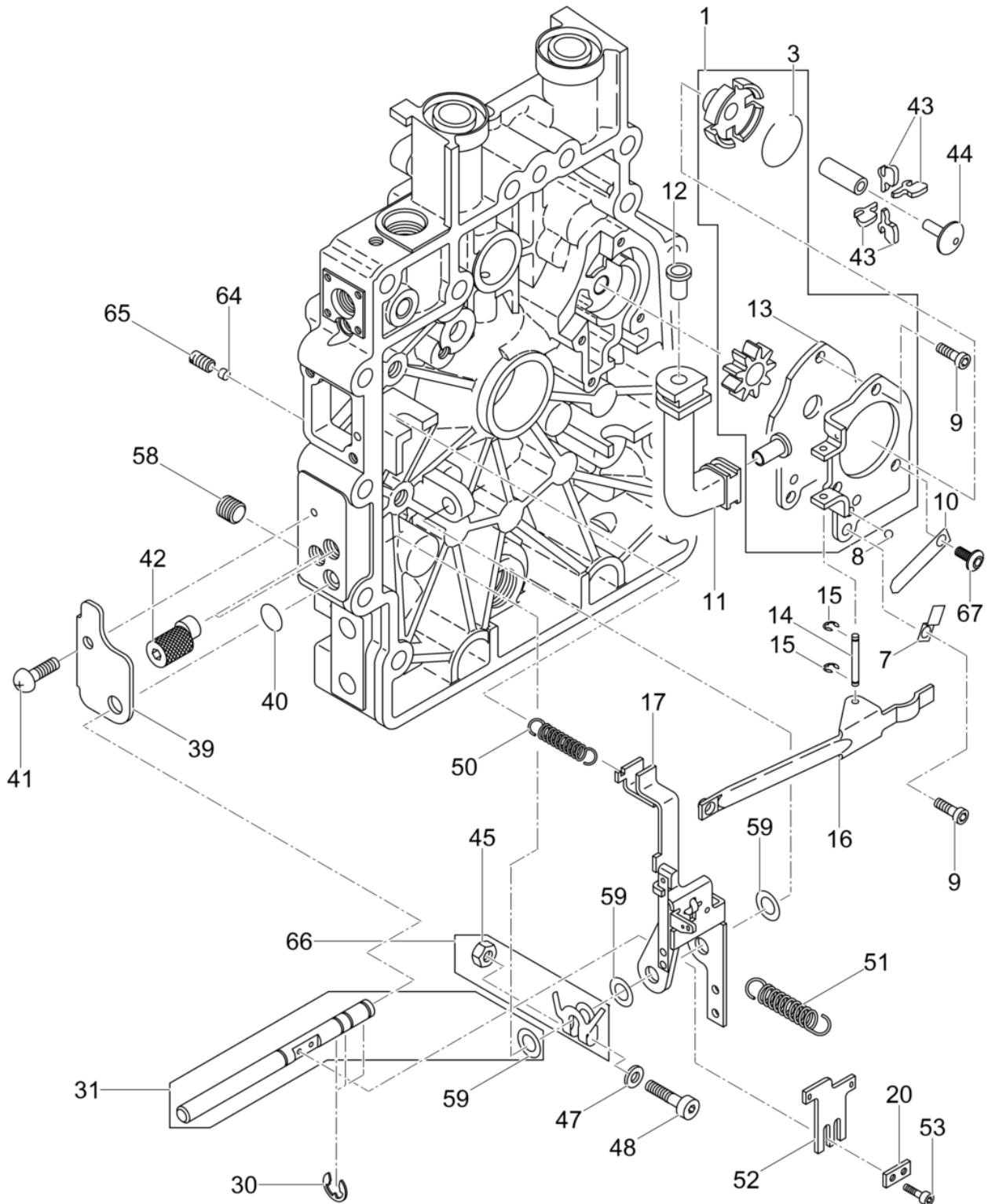

DPS1850H BASIC

Ölpumpe, Regler, Drehzahlverstellung
 Oil pump, governor, adjustment r.p.m.
 Bomba de aceite, regulador, ajuste del no de r.p.m.
 Pompe à huile, régulateur,

Pos. Item	Artikel Nr. Item no.	Pc.	Unit	Beschreibung Descripción	Description Description	Abm. Dim.	Norm Standard
						Drehmoment Torque	Schmierstoff Lubricant
1	5000207031	1	pc	Ölpumpe Bomba de aceite	Oil pump Pompe à huile		
3	5000207032	1	pc	Sprengring Anillo de retención	Snap ring Circlip		
7	5000108778	1	pc	Winkel Banda de retención	Retaining strap Sangle de fixation		
8	5000108779	1	pc	Kugel Bola	Ball Bille	3.5	
9	5000151308	3	pc	Zylinderschraube Tornillo cilíndrico	Cheese head screw Vis à tête cylindrique	M5 x 12	DIN6912
10	5000108777	1	pc	Feder Resorte	Spring Ressort	0.4	
11	5000108775	1	pc	Ölleitung Tubo	Tube Tube		
12	5000108774	1	pc	Rohrriete Remache de tubo	Pipe rivet Rivet de tube		
13	5000108776	1	pc	Rohrriete Remache de tubo	Pipe rivet Rivet de tube		
14	5000108781	1	pc	Stift Eje	Shaft Arbre		
15	5000108780	2	pc	Sicherungsscheibe Arandela de seguridad	Lock washer Rondelle d'arrêt	1.9	DIN6799
16	5000108785	1	pc	Hebel Palanca	Lever Levier		
17	5000151316	1	pc	Reglerhebel Palanca del gobernador	Governor lever Levier régulateur		
20	5000108789	1	pc	Zwischenplatte Placa intermedia	Intermediate plate Plaque intermediaire		
30	5000151327	3	pc	Sicherungsscheibe Arandela de seguridad	Lock washer Rondelle d'arrêt	7	DIN6799
31	5000217601	1	pc	Welle Árbol	Shaft Arbre		
39	5000151330	1	pc	Platte Drehzahlverstellung Ajuste del no de r.p.m. placa	Adjustment r.p.m. plate Réglage du régime moteur		
40	5000108801	1	pc	O-Ring Anillo-o	O-ring Bague-o	8 x 2	
41	5000151328	1	pc	Flachkopfschraube Tornillo de cabeza plana	Pan head screw Vis lentiforme	M5 x 12	DIN7380
42	5000129004	2	pc	Exzentrerschraube Tornillo excéntrico	Eccentric screw Vis excentrique		
43	5000207034	4	pc	Reglergewichte Contrapeso del regulador	Governor weight Masselotte		
44	5000108773	1	pc	Druckstück Manguito	Sleeve Douille		
45	5100051902	1	pc	Sechskantmutter Tuerca hexagonal	Hexagon nut Écrou hexagonal		
47	5000129517	1	pc	Scheibe Arandela	Washer Rondelle	A5,3	ISO7089
48	5100051906	1	pc	Zylinderschraube Tornillo cilíndrico	Cheese head screw Vis à tête cylindrique		
50	5000209739	1	pc	Zugfeder Resorte de tracción	Tension spring Ressort de traction		
51	5200022006	1	pc	Reglerfeder Resorte del regulador	Governor spring Ressort régulateur		
52	5000108787	1	pc	Blech Regulador	Control Commande		



Ölpumpe, Regler, Drehzahlverstellung
 Oil pump, governor, adjustment r.p.m.
 Bomba de aceite, regulador, ajuste del no de r.p.m.
 Pompe à huile, régulateur,

DPS185OH BASIC

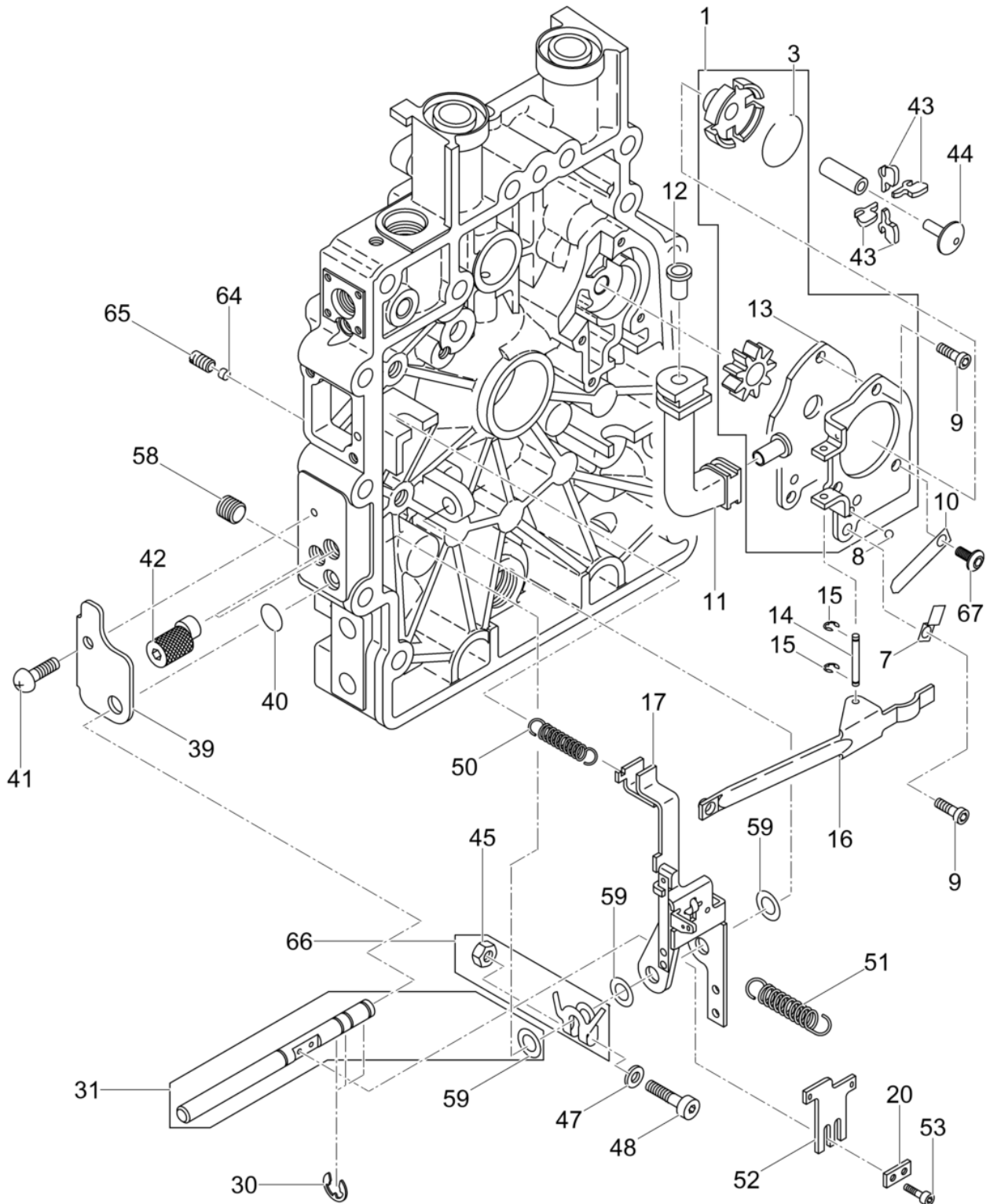

DPS1850H BASIC

Ölpumpe, Regler, Drehzahlverstellung
 Oil pump, governor, adjustment r.p.m.
 Bomba de aceite, regulador, ajuste del no de r.p.m.
 Pompe à huile, régulateur,

Pos. Item	Artikel Nr. Item no.	Pc.	Unit	Beschreibung Descripción	Description Description	Abm. Dim.	Norm Standard
						Drehmoment Torque	Schmierstoff Lubricant
53	5000108788	2	pc	Zylinderschraube Tornillo cilíndrico	Cheese head screw Vis à tête cylindrique	M3 x 8	
58	5000151353	1	pc	Gewindestift Varilla roscada	Threaded pin Goupille fileté	M10 x 10	
59	5000151354	3	pc	Passscheibe Arandela de ajuste	Shim ring Disque dajustage	8 x 14 x 1	DIN988
64	5000226321	1	pc	Stopfen Enchufe	Plug Prise	4,5x3	
65	5000226322	1	pc	Gewindestift Varilla roscada	Threaded pin Goupille fileté	M6x10	
66	5100038981	1	pc	Anschlag Kpl. Tope cpl.	Stop cpl. Butée cpl.		
67	5100013784	1	pc	Linsenschraube Tornillo gota de sebo	Countersunk screw Vis à tête bombée	M5x12	



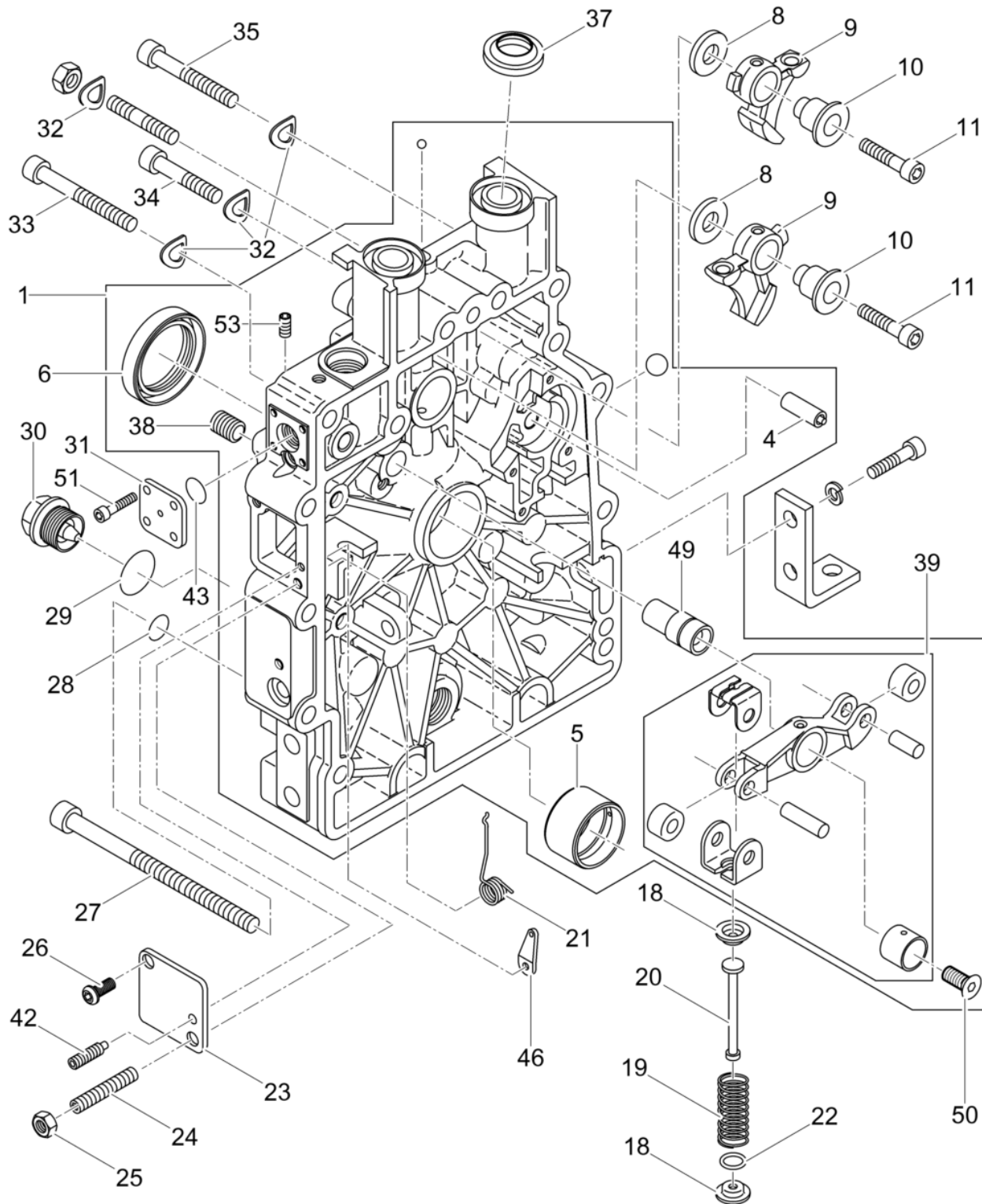

DPS1850H BASIC

Steuerdeckel Command cover Tapa del mando Couvercle de commande

Pos. Item	Artikel Nr. Item no.	Pc.	Unit	Beschreibung Descripción	Description Description	Abm. Dim.	Norm Standard
						Drehmoment Torque	Schmierstoff Lubricant
1	5200007455	1	pc	Steuerdeckel Tapa de mando	Timing cover Couvercle de distribution		
4	5000151356	1	pc	Bolzen Perno	Bolt Boulon		
5	5000108763	1	pc	Lagerbüchse Rodamiento	Bearing Roulement		
5	5000129006	1	pc	Lagerbüchse Caja del cojinete	Bearing bushing Douille de roulement	0,5	
6	5000014458	1	pc	Wellendichtring Empaque	Seal Joint		
8	5000104365	2	pc	Scheibe Arandela	Washer Rondelle	10.1 x 22 x 3	
9	5000108755	2	pc	Schlepphebel Leva	Cam Came		
10	5000094936	2	pc	Buchse Rodillo de leva	Cam follower spindle shaft Contre-came		
11	5000151361	2	pc	Zylinderschraube Tornillo cilíndrico	Cheese head screw Vis à tête cylindrique	M6 x 25	ISO4762
18	5000108760	2	pc	Federteller Taza	Cup Ecuelle		
19	5000108762	1	pc	Feder Resorte de presión	Pressure spring Ressort de pression		
20	5000108761	1	pc	Zugstange Varilla	Rod Tringle		
21	5000108764	1	pc	Rückholfeder Resorte del regulador	Governor spring Ressort régulateur		
22	5000151366	1	pc	Scheibe Arandela	Washer Rondelle	10.7 x 19 x 0.5	
23	5000108766	1	pc	Deckel Tapa	Cover Couvercle		
24	5000151368	1	pc	Gewindestift Varilla roscada	Threaded pin Goupille fileté	M6 x 30	DIN913
25	5000151323	1	pc	Sechskantmutter Contratuerca	Locknut Contre-écrou	M6	ISO4032
26	5100038983	1	pc	Linsenschraube 6X14 Tornillo gota de sebo	Countersunk screw Vis à tête bombée		
27	5000129519	2	pc	Zylinderschraube Tornillo cilíndrico	Cheese head screw Vis à tête cylindrique	M8 x 120	
28	5000107556	2	pc	Dichtring Anillo de junta	Gasket Bague d'étanchéité	A8 x 14	DIN7603
29	5000202416	1	pc	Öldichtung Junta de aceite	Oil seal Joint d'huile	52 x 80 x 10	
30	5000202314	1	pc	Verschlusschraube Tapón roscado	Oil plug Bouchon	AM 22x 1,5	DIN7604
31	5000151372	1	pc	Deckel Tapa	Cover Couvercle		
32	5200022048	13	pc	Tellerfeder Arandela de resorte	Spring washer Ressort belleville	A8	
33	5000126979	1	pc	Zylinderschraube Tornillo cilíndrico	Cheese head screw Vis à tête cylindrique	M8 x 60	DIN912
34	5000151375	2	pc	Zylinderschraube Tornillo cilíndrico	Cheese head screw Vis à tête cylindrique	M8 x 45	ISO4762
35	5000151376	10	pc	Zylinderschraube Tornillo cilíndrico	Cheese head screw Vis à tête cylindrique	M8 x 50	ISO4762
37	5000108770	2	pc	Dichtring Anillo sellante	Seal ring Bague d'étanchéité		



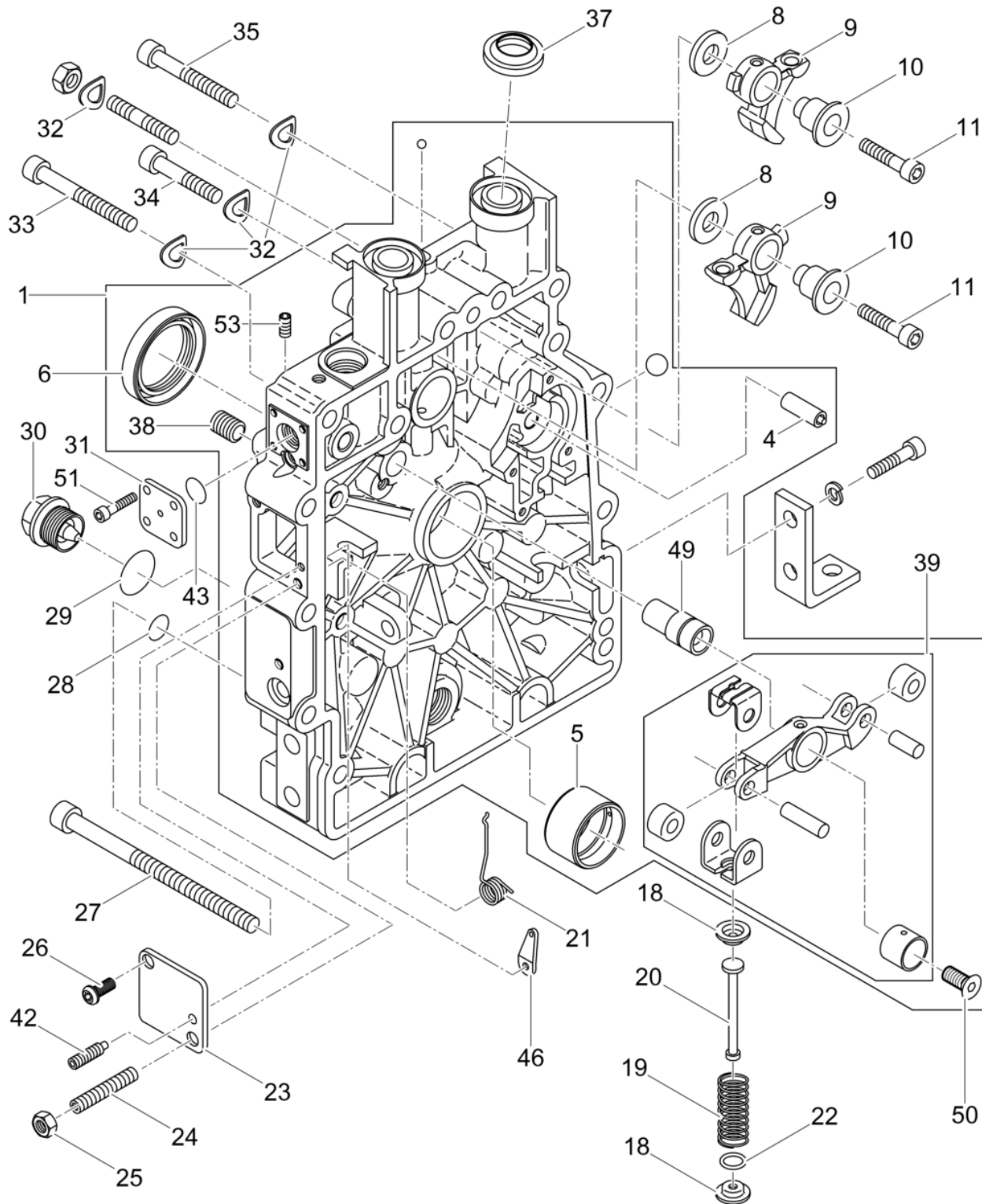

DPS1850H BASIC**Steuerdeckel
Command cover
Tapa del mando
Couvercle de commande**

Pos. Item	Artikel Nr. Item no.	Pc.	Unit	Beschreibung Descripción	Description Description	Abm. Dim.	Norm Standard
						Drehmoment Torque	Schmierstoff Lubricant
38	5000202302	5	pc	Gewindestift Varilla roscada	Threaded pin Goupille fileté	M8 x 10	DIN913
39	5000207037	1	pc	Kipphebel Balancín de escapebalancín	Exhaust rocker arm Culbuteurculbuteur		
42	5000108765	1	pc	Gewindestift Tornillo	Screw Vis	M4 x 20	DIN915
43	5000094934	1	pc	O-Ring Anillo-o	O-ring Joint torique	9,5 x 2,5	
46	5000151383	1	pc	Hebel Palanca	Lever Levier		
49	5000215778	1	pc	Kipphebelachse Seguro	Lock Verrou		
50	5000108929	4	pc	Senkschraube Tornillo	Screw Vis	M6 x 35	DIN7991
51	5000151341	1	pc	Zylinderschraube Tornillo cilíndrico	Cheese head screw Vis à tête cylindrique	M4 x 10	ISO4762
53	5000107715	1	pc	Stift Pasador	Pin Goupille	M6 x 10	



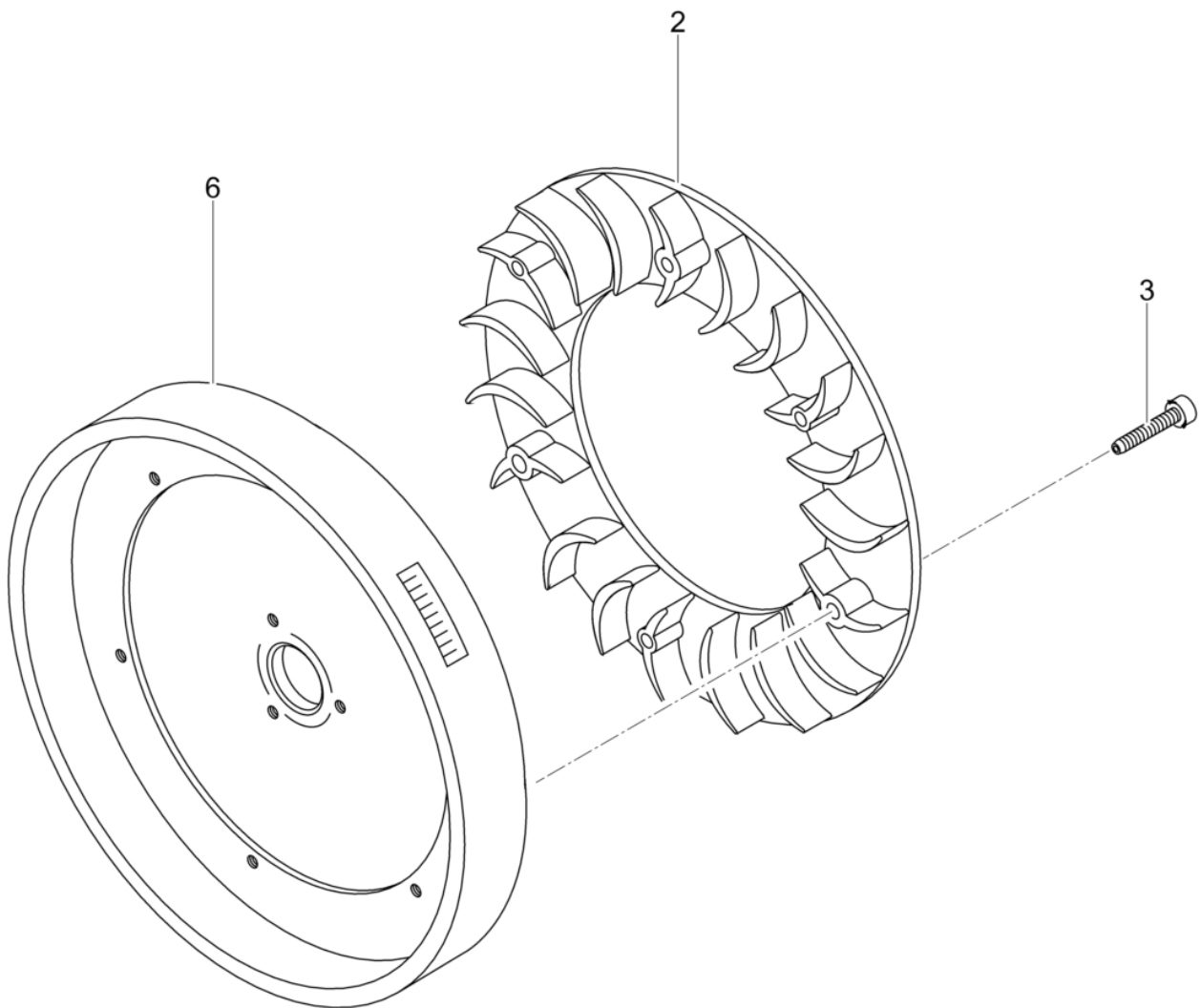

DPS1850H BASIC**Gebläse, Schwungrad
Blower, fly wheel
Ventilador, volante
Ventilateur, volant**

Pos. Item	Artikel Nr. Item no.	Pc.	Unit	Beschreibung Descripción	Description Description	Abm. Dim.	Norm Standard
						Drehmoment Torque	Schmierstoff Lubricant
2	5000108711	1	pc	Lüfterrad Anillo	Ring Anneau		
3	5100051904	6	pc	Zylinderschraube Tornillo cilíndrico	Cheese head screw Vis à tête cylindrique		
6	5000129509	1	pc	Schwungrad Volante	Flywheel Volant		



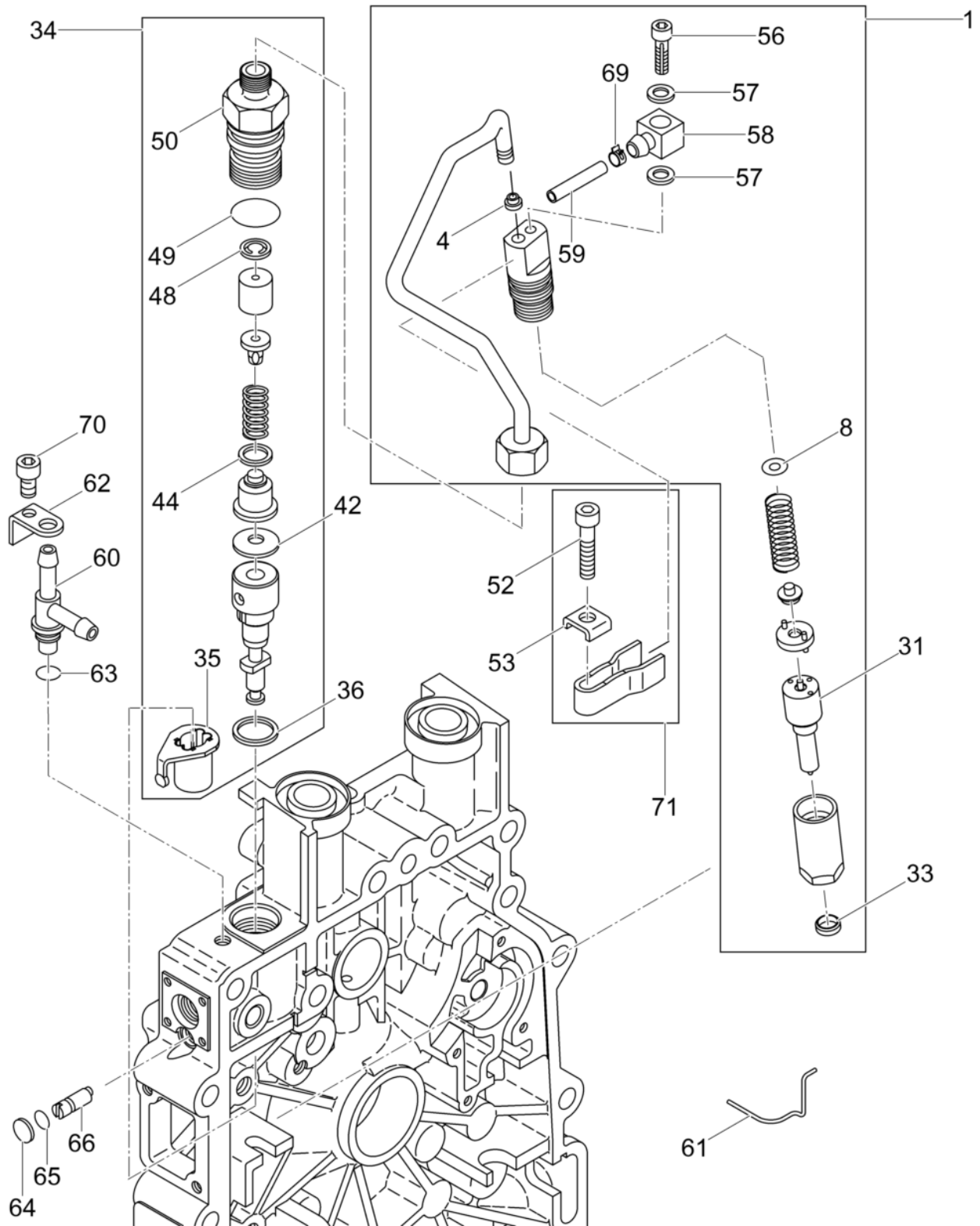

Pos. Item	Artikel Nr. Item no.	Pc.	Unit	Beschreibung Descripción	Description Description	Abm. Dim.	Norm Standard
						Drehmoment Torque	Schmierstoff Lubricant
1	5100051959	1	pc	Einspritzventil Kpl. Válvula de inyección cpl.	Injection valve cpl. Soupape de injection cpl.		
4	5000151396	1	pc	Dichtkonus Cono de obturación	Sealing cone Cône d'étanchéité	5,3 LG	
8	5000151417	1	pc	Einstellscheibe Arandela de ajuste	Adjusting washer Rondelle de réglage	1,94	
8	5000151416	1	pc	Einstellscheibe Arandela de ajuste	Adjusting washer Rondelle de réglage	1,90	
8	5000151415	1	pc	Einstellscheibe Arandela de ajuste	Adjusting washer Rondelle de réglage	1,84	
8	5000151414	1	pc	Einstellscheibe Arandela de ajuste	Adjusting washer Rondelle de réglage	1,80	
8	5000151413	1	pc	Einstellscheibe Arandela de ajuste	Adjusting washer Rondelle de réglage	1,74	
8	5000151412	1	pc	Einstellscheibe Arandela de ajuste	Adjusting washer Rondelle de réglage	1,70	
8	5000151411	1	pc	Einstellscheibe Arandela de ajuste	Adjusting washer Rondelle de réglage	1,64	
8	5000151410	1	pc	Einstellscheibe Arandela de ajuste	Adjusting washer Rondelle de réglage	1,60	
8	5000151409	1	pc	Einstellscheibe Arandela de ajuste	Adjusting washer Rondelle de réglage	1,54	
8	5000151408	1	pc	Einstellscheibe Arandela de ajuste	Adjusting washer Rondelle de réglage	1,50	
8	5000151407	1	pc	Einstellscheibe Arandela de ajuste	Adjusting washer Rondelle de réglage	1,44	
8	5000151406	1	pc	Einstellscheibe Arandela de ajuste	Adjusting washer Rondelle de réglage	1,40	
8	5000151405	1	pc	Einstellscheibe Arandela de ajuste	Adjusting washer Rondelle de réglage	1,34	
8	5000151404	1	pc	Einstellscheibe Arandela de ajuste	Adjusting washer Rondelle de réglage	1,30	
8	5000151403	1	pc	Einstellscheibe Arandela de ajuste	Adjusting washer Rondelle de réglage	1,24	
8	5000151402	1	pc	Einstellscheibe Arandela de ajuste	Adjusting washer Rondelle de réglage	1,20	
8	5000151401	1	pc	Einstellscheibe Arandela de ajuste	Adjusting washer Rondelle de réglage	1,14	
8	5000151400	1	pc	Einstellscheibe Arandela de ajuste	Adjusting washer Rondelle de réglage	1,10	
8	5000151399	1	pc	Einstellscheibe Arandela de ajuste	Adjusting washer Rondelle de réglage	1,04	
8	5000151398	1	pc	Einstellscheibe Arandela de ajuste	Adjusting washer Rondelle de réglage	1,00	
31	5000226323	1	pc	Einspritzdüse Inyector	Injection nozzle Injecteur		
33	5000108805	1	pc	Dichtscheibe Empaque	Seal Joint		
34	5000226317	1	pc	Einspritzpumpe Kpl. Bomba de inyección cpl.	Injection pump cpl. Pompe à injection cpl.		
35	5000108806	1	pc	Reglerbuchse Manguito	Sleeve Douille		
36	5000108809	1	pc	Ausgleichsscheibe Laminilla	Shim Cale	0,2	
36	5000108810	1	pc	Ausgleichsscheibe Laminilla	Shim Cale	0,3	

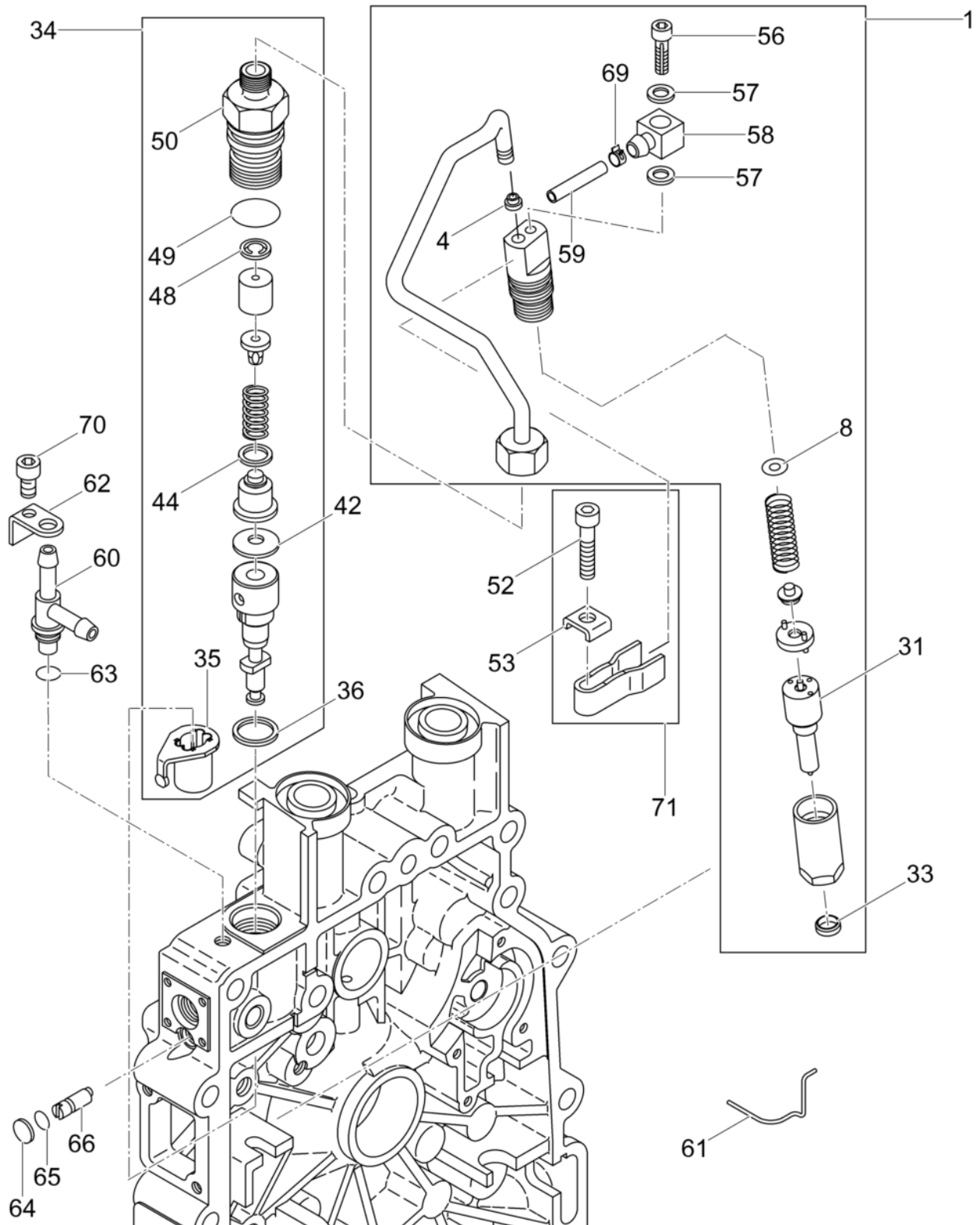

Pos. Item	Artikel Nr. Item no.	Pc.	Unit	Beschreibung Descripción	Description Description	Abm. Dim.	Norm Standard
						Drehmoment Torque	Schmierstoff Lubricant
36	5000108811	1	pc	Ausgleichsscheibe Laminilla	Shim Cale	0,4	
36	5000108812	1	pc	Ausgleichsscheibe Laminilla	Shim Cale	0,5	
36	5000108813	1	pc	Ausgleichsscheibe Laminilla	Shim Cale	0,6	
42	5000151427	1	pc	Spannscheibe Arandela elástica	Spring washer Disque de serrage		
44	5000151428	1	pc	Scheibe Arandela	Washer Rondelle		
48	5000205822	1	pc	Ventilplatte Tapa	Cover Couvercle		
49	5000151429	1	pc	O-Ring Anillo-o	O-ring Joint torique	17 x 2	
50	5100038985	1	pc	Druckventilhalter Válvula presión soporte	Pressure valve holder Pressostat attache		
52	5000129007	1	pc	Zylinderschraube Tornillo cilíndrico	Cheese head screw Vis à tête cylindrique	M6 x 30	ISO4762
53	5000108808	1	pc	Scheibe Arandela	Washer Rondelle		
56	5000227674	1	pc	Zylinderschraube Tornillo cilíndrico	Cheese head screw Vis à tête cylindrique		
57	5000151439	2	pc	Dichtring Anillo de junta	Gasket Bague détanchéité	A4 x 8	DIN7603
58	5000108803	1	pc	Anschlußstück Conector	Connector Connexion		
59	5000128968	1	pc	Kraftstoffleitung Tubería de combustible	Fuel pipe Tuyau à combustible	2,5 x 195	
60	5000209682	1	pc	T-Stück Pieza t	T-piece T-pièce		
61	5000151369	1	pc	Haltefeder Resorte de sujeción	Retaining spring Ressort de retenue		
62	5200022043	1	pc	Konsole Soporte	Bracket Support		
63	5000071130	1	pc	O-Ring Anillo-o	O-ring Bague-o	7,5 x 10,5 x 1,5	
64	5000108816	1	pc	Verschlusscheibe Arandela de cierre	Plug washer Rondelle de fermeture	8	DIN470
65	5000094905	1	pc	O-Ring Anillo-o	O-ring Joint torique		
66	5000151433	1	pc	Exzenterbolzen Perno excéntrico	Eccentric pin Boulon d'excentrage		
69	5000215785	1	pc	Schlauchklemme Abrazadera	Clamp Collier de serrage	6	
70	5000217620	1	pc	Zylinderschraube Tornillo cilíndrico	Cheese head screw Vis à tête cylindrique	M5x25	
71	5100051943	1	pc	Düsenhalter Portainyector	Injector holder Porte-injecteur		

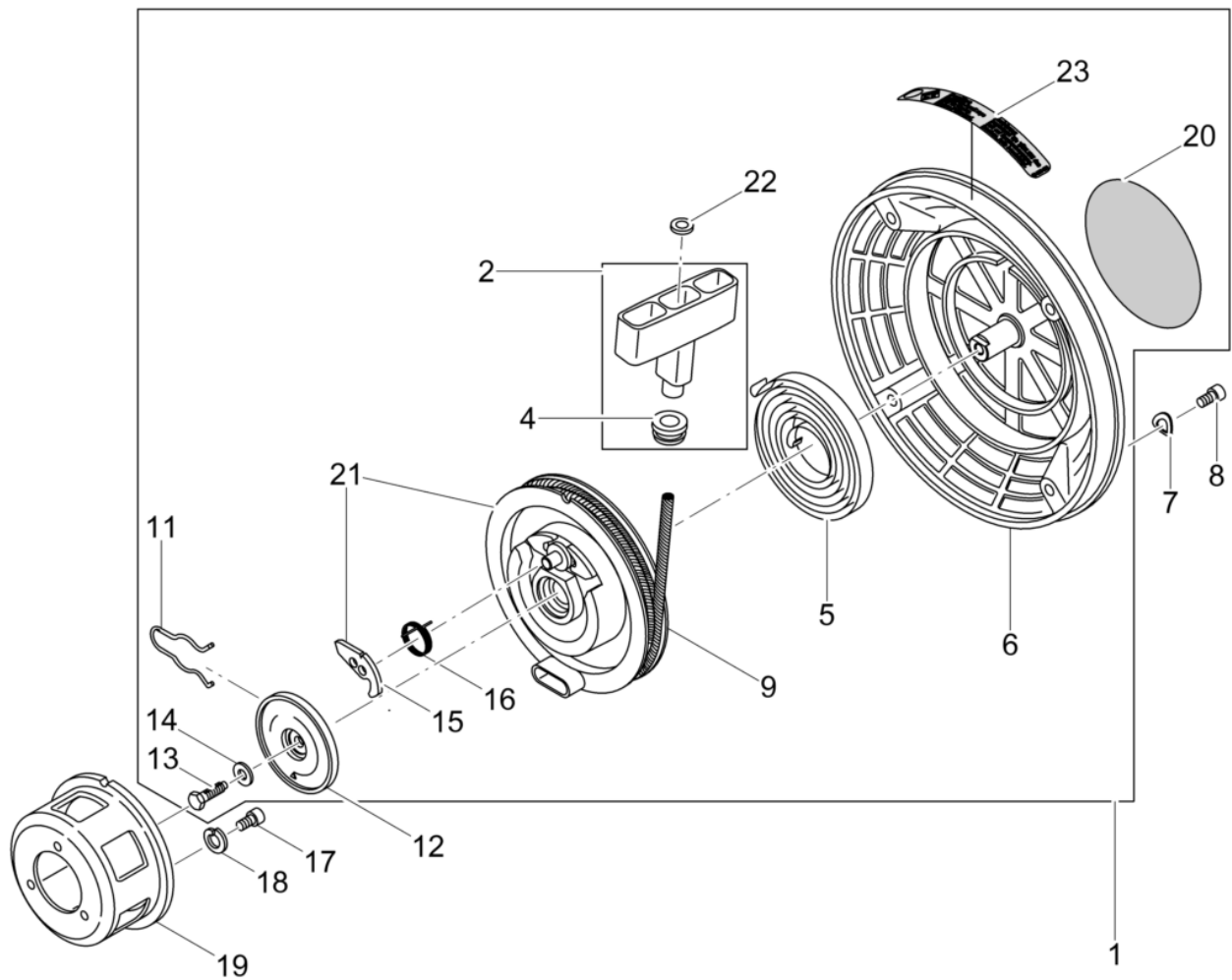

DPS1850H BASIC

Reversierstarter Recoil starter Starter reversible Démarrreur réversible

Pos. Item	Artikel Nr. Item no.	Pc.	Unit	Beschreibung Descripción	Description Description	Abm. Dim.	Norm Standard
						Drehmoment Torque	Schmierstoff Lubricant
1	5100051946	1	pc	Rversierstarter Starter reversible	Recoil starter Démarrreur réversible		
2	5000108830	1	pc	Griff Kpl. Empuñadura del arranque	Starter handle Poignée du lanceur		
4	5000058711	1	pc	Gummitülle Casquillo de goma	Rubber funnel Passe fil en caoutchouc	0,390in	
5	5000108827	1	pc	Rückholfeder Resorte	Spring Ressort		
6	5000108826	1	pc	Startergehäuse Caja del arrancador	Starter housing Carter de démarrage		
7	5000151290	4	pc	Federscheibe Arandela elástica	Spring washer Rondelle à ressort	A6	DIN137
8	5000129016	4	pc	Zylinderschraube Tornillo cilíndrico	Cheese head screw Vis à tête cylindrique	M6 x 12	ISO4762
9	5000205791	1	pc	Starterseil Cuerda	Rope Corde		
11	5000108831	1	pc	Bremsfeder Resorte de freno	Brake spring Ressort de décélération		
12	5000108834	1	pc	Bremsscheibe Arandela	Washer Rondelle		
13	5000151452	1	pc	Sechskantschraube Tornillo hexagonal	Hexagonal head cap screw Vis à tête hexagonale	M6 x 18	DIN933
14	5000207593	1	pc	Spannscheibe Arandela elástica	Spring washer Disque de serrage		
15	5000108833	1	pc	Klinke Trinquete	Ratchet (pawl) Cliquet		
16	5000108832	1	pc	Drehfeder Resorte	Torsion spring Ressort		
17	5000151448	3	pc	Zylinderschraube Tornillo cilíndrico	Cheese head screw Vis à tête cylindrique	M6 x 10	ISO4762
18	5000151456	3	pc	Federring Arandela elástica	Lock washer Rondelle de ressort	6	DIN128
19	5000108835	1	pc	Mitnehmertopf Manguito	Sleeve Douille		
20	5000227678	1	pc	Aufkleber Calcomanias	Labels Autocollants		
21	5000069666	1	pc	Seilscheibe Und Klinke Polea para cuerda y trinquete	Rope disc and ratchet Poulie de démarrage et cliquet		
22	5000129008	1	pc	Scheibe Arandela	Washer Rondelle	5,3	DIN9021
23	5000215784	1	pc	Aufkleber Calcomania	Label Autocollant		



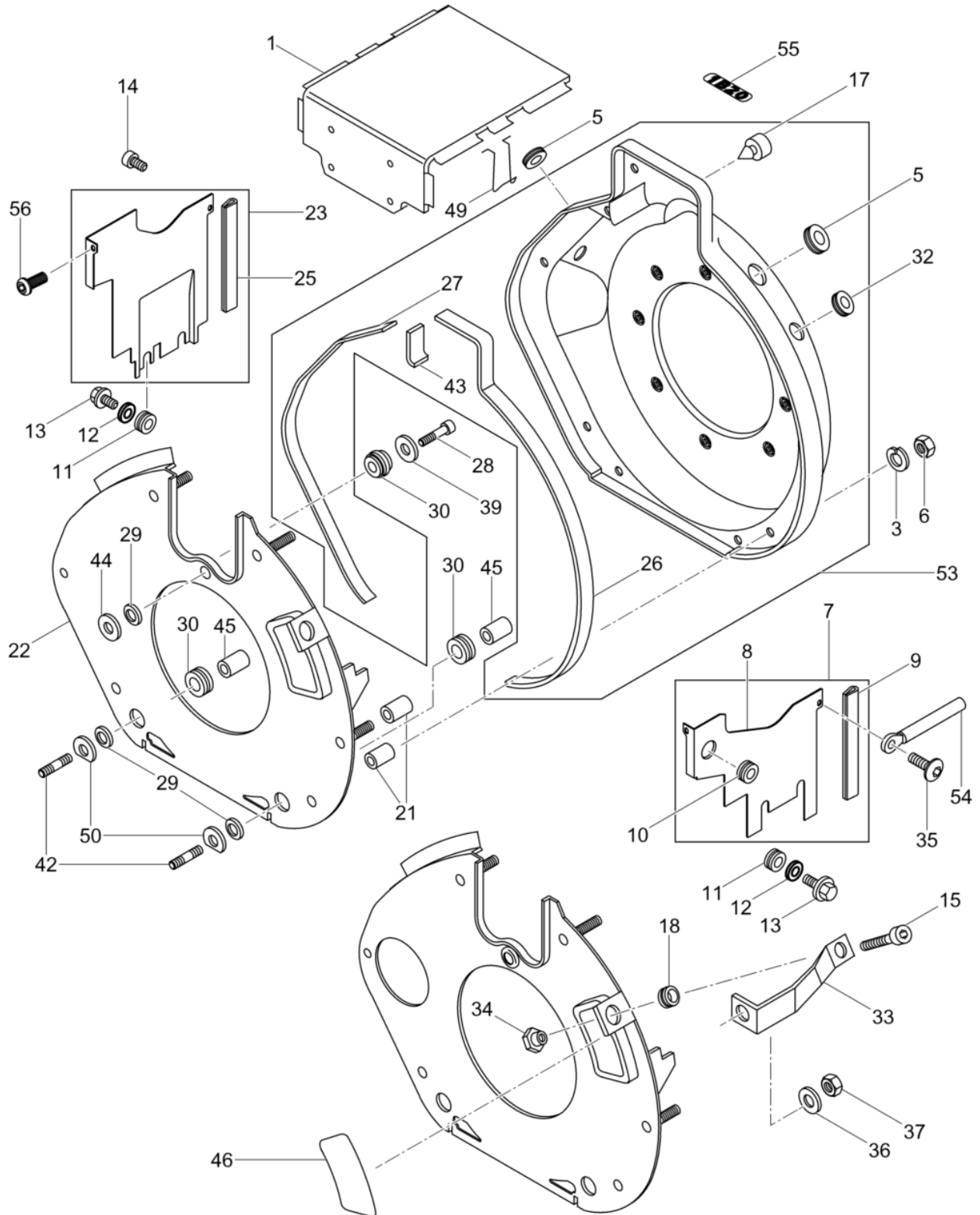

Pos. Item	Artikel Nr. Item no.	Pc.	Unit	Beschreibung Descripción	Description Description	Abm. Dim.	Norm Standard
						Drehmoment Torque	Schmierstoff Lubricant
1	5000108836	1	pc	Abdeckblech Cubierta de chapa	Cover plate Tôle de recouvrement		
3	5000151456	6	pc	Federring Arandela elástica	Lock washer Rondelle de ressort	6	DIN128
5	5000129520	2	pc	Gummitülle Casquillo de goma	Rubber funnel Passe fil en caoutchouc		
6	5000151323	6	pc	Sechskantmutter Contratuerca	Locknut Contre-écrou	M6	ISO4032
7	5000108839	1	pc	Blech Kpl. Cubierta	Duct Canal d'air		
9	5000108841	1	pc	Dichtleiste Empaque	Seal Joint		
10	5000107379	1	pc	Gummitülle Ojal	Grommet Passe-fil		
11	5000108842	4	pc	Gummitülle Manguito	Sleeve Douille		
13	5000108844	3	pc	Schraube Tornillo	Screw Vis	DE M4 x 10	DIN7500
14	5100038983	1	pc	Linsenschraube 6X14 Tornillo gota de sebo	Countersunk screw Vis à tôle bombée		
15	5000151231	1	pc	Zylinderschraube Tornillo cilíndrico	Cheese head screw Vis à tête cylindrique	M6 x 16	ISO4762
17	5100038989	1	pc	Gummitülle Ojal	Grommet Passe-fil		
18	5000108845	1	pc	Gummitülle Casquillo de goma	Rubber funnel Passe fil en caoutchouc		
21	5000108852	5	pc	Hülse Tubo	Spacer tube Tube	6,5 x 12 x 18	
22	5000129502	1	pc	Trennblech Placa separadora	Baffle plate Separateur		
23	5000129491	1	pc	Blech Chapa	Plate Tôle		
25	5000108841	1	pc	Dichtleiste Empaque	Seal Joint		
26	5200022031	1	pc	Dichtung Empaque	Seal Joint	520	
27	5100051921	1	pc	Dichtleiste Regleta sellante	Sealing rail Baguette d'étanchéité		
28	5000129010	1	pc	Zylinderschraube Tornillo cilíndrico	Cheese head screw Vis à tête cylindrique	M6 x 25	DIN912
29	5000107800	3	pc	Dichtungsring Anillo sellante	Sealing ring Bague d'étanchéité		
30	5000209664	3	pc	Distanzhülse Manguito distanciador	Spacer sleeve Douille d'écartement		
32	5000108838	1	pc	Gummitülle Manguito	Sleeve Douille		
33	5000108847	1	pc	Abstützung Soporte	Bracket Support		
34	5000108846	1	pc	Schraube Tornillo	Screw Vis		
35	5100038983	1	pc	Linsenschraube 6X14 Tornillo gota de sebo	Countersunk screw Vis à tôle bombée		
36	5200022048	1	pc	Tellerfeder Arandela de resorte	Spring washer Ressort belleville	A8	
37	5000151379	1	pc	Sechskantmutter Contratuerca	Locknut Contre-écrou	M8	ISO4032

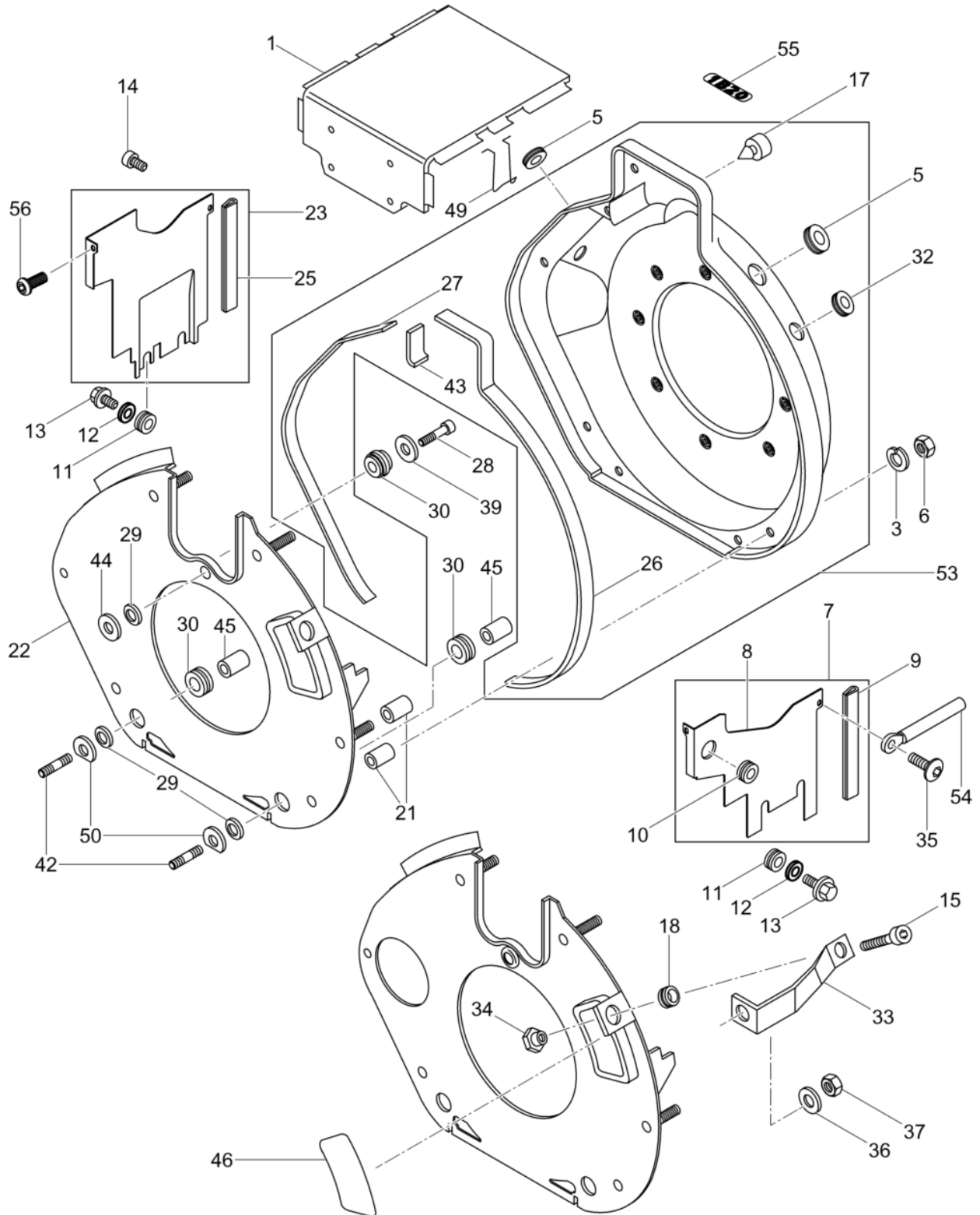

Pos. Item	Artikel Nr. Item no.	Pc.	Unit	Beschreibung Descripción	Description Description	Abm. Dim.	Norm Standard
						Drehmoment Torque	Schmierstoff Lubricant
39	5000151456	1	pc	Federring Arandela elástica	Lock washer Rondelle de ressort	6	DIN128
42	5000108850	2	pc	Stiftschraube Tornillo espárrago	Stud bolt Goupille fileté	M6 x 45	DIN835
43	5000108856	1	pc	Dichtungsprofil Empaque	Seal Joint	48	
44	5000108851	1	pc	Scheibe Arandela	Washer Rondelle	6,5 x 22,5 x 1	
45	5000108852	2	pc	Hülse Tubo	Spacer tube Tube	6,5 x 12 x 18	
46	5000202307	1	pc	Verschlußdeckel Tapa del tanque de combustible	Fuel tank cap Chapeau de réservoir à essence		
49	5000129513	1	pc	Feder Resorte	Spring Ressort		
50	5000151482	2	pc	Scheibe Arandela	Washer Rondelle		
53	5100051950	1	pc	Gehäuse Carcasa	Housing Carter		
54	5000097590	1	pc	Schelle Abrazadera	Clamp Agrafe		
55	5000215783	1	pc	Aufkleber Calcomania	Label Autocollant		
56	5100038983	2	pc	Linsenschraube 6X14 Tornillo gota de sebo	Countersunk screw Vis à tôle bombée		

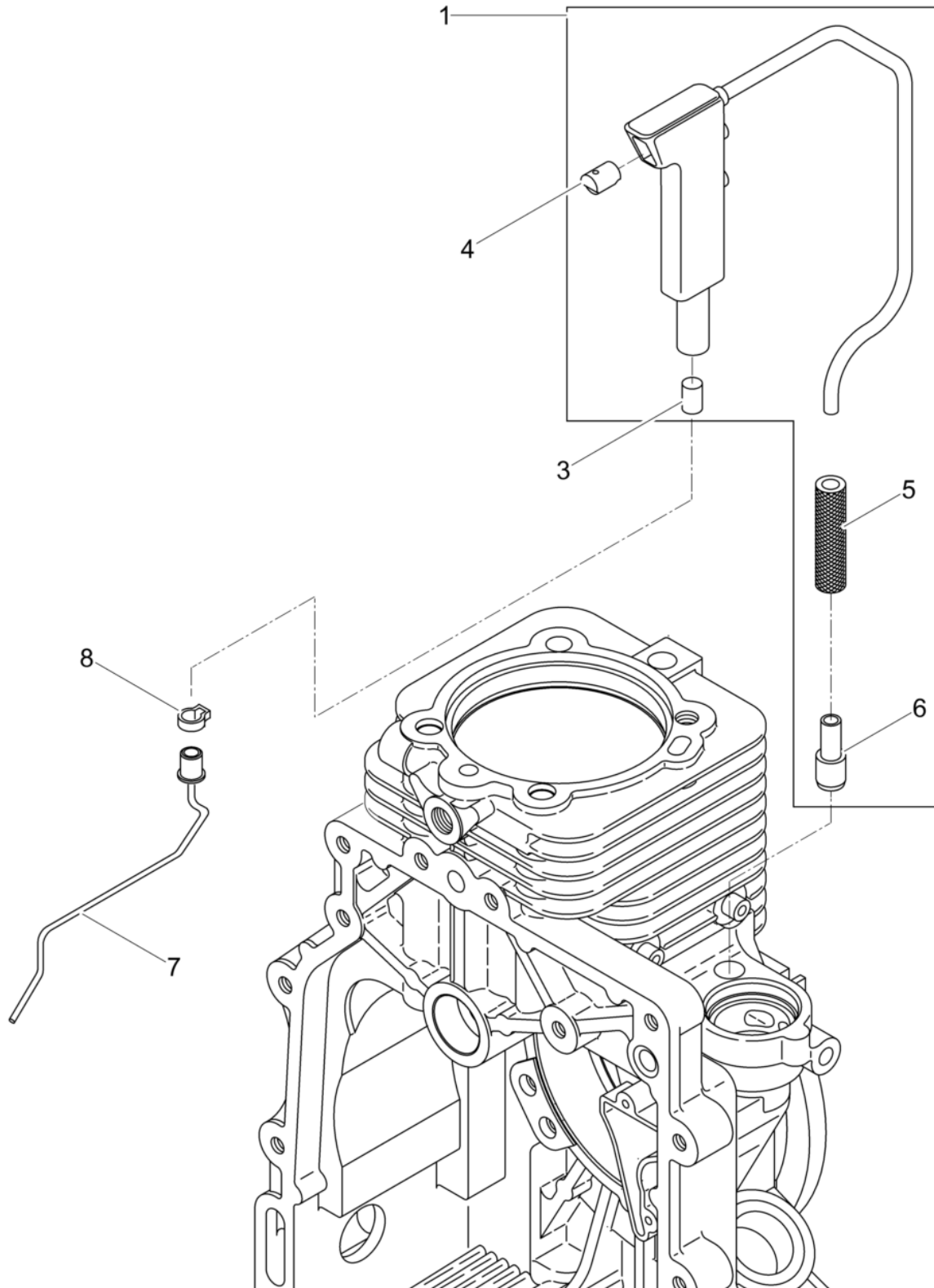

DPS1850H BASIC**Kurbelgehäuseentlüftung
Crankcase breathing system
Purgado de cárter
Raccord fileté de purge**

Pos. Item	Artikel Nr. Item no.	Pc.	Unit	Beschreibung Descripción	Description Description	Abm. Dim.	Norm Standard
						Drehmoment Torque	Schmierstoff Lubricant
1	5000209691	1	pc	Ölabscheider Separador de aceite	Oil separator Séparateur d'huile		
3	5000108822	1	pc	Filtereinsatz Cartucho filtrante	Filter insert Element filtrant		
4	5000108899	1	pc	Stopfen Tapón	Push-in plug Bouchon		
5	5000209712	1	pc	Kraftstoffleitung Manguera de combustible	Fuel hose Tuyau à essence	6x35	
6	5000209730	1	pc	Nippel Boquilla roscada	Nipple Raccord fileté		
7	5000108820	1	pc	Saugrohr Tubo aspirante	Suction pipe Tuyau d'aspiration		
8	5000202305	1	pc	Schlauchklemme Abrazadera	Clamp Collier de serrage		



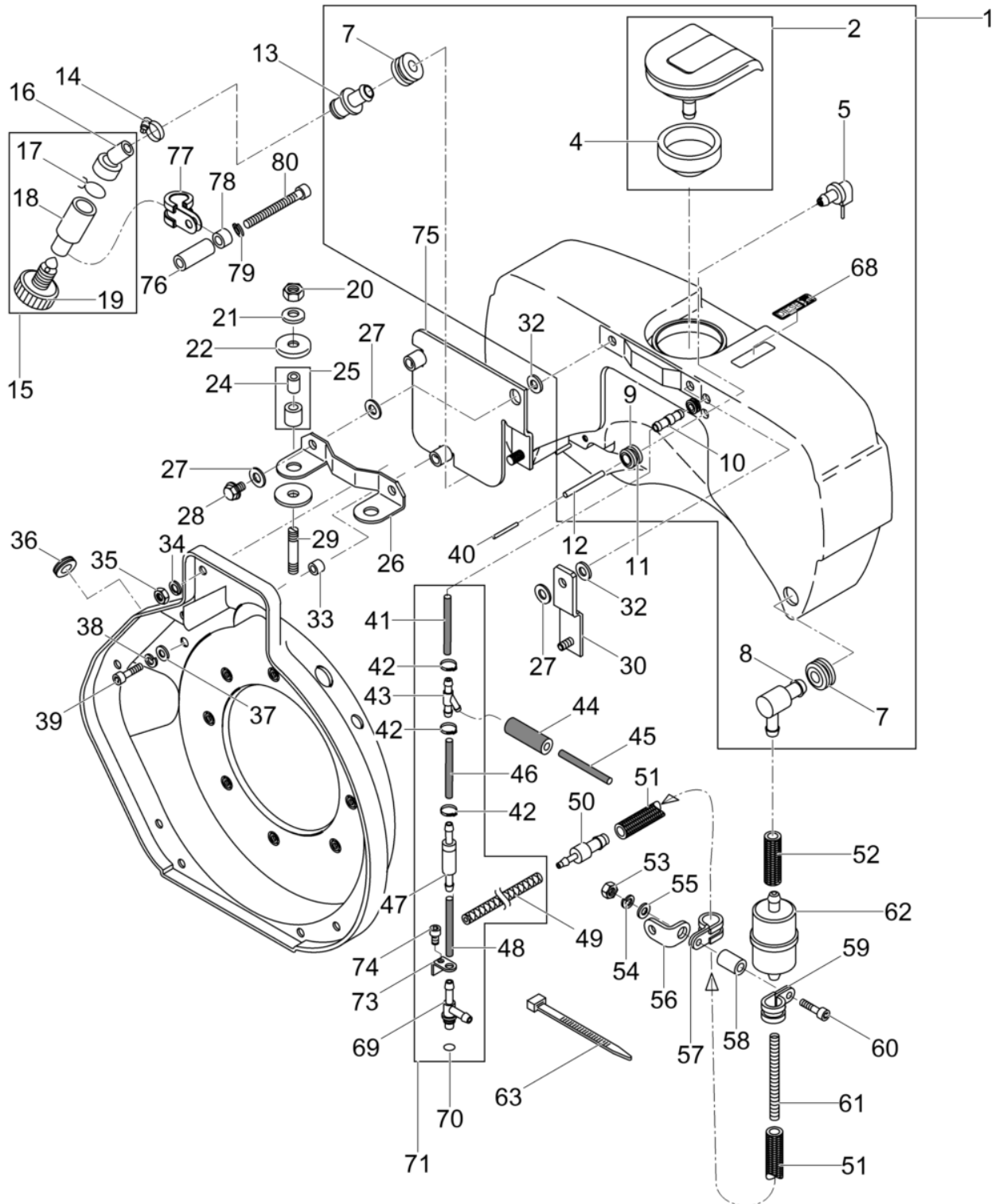

Pos. Item	Artikel Nr. Item no.	Pc.	Unit	Beschreibung Descripción	Description Description	Abm. Dim.	Norm Standard
						Drehmoment Torque	Schmierstoff Lubricant
1	5100051947	1	pc	Kraftstofftank Depósito de combustible	Fuel tank Réservoir à essence		
2	5000108861	1	pc	Tankverschluß Tapa	Cap Couvercle		
4	5000108864	1	pc	Formstück Junta	Gasket Joint		
5	5000108870	1	pc	Ventil Válvula	Valve Soupape		
7	5000108874	2	pc	Gummitülle Manguito	Sleeve Douille		
8	5000209869	1	pc	Anschlussnippel Boquilla de conexión	Connecting nipple Raccord fileté		
9	5000108885	1	pc	Gummitülle Manguito	Sleeve Douille		
10	5000128962	1	pc	Nippel Boquilla roscada	Nipple Raccord fileté		
11	5100038991	1	pc	Gummitülle Ojal	Grommet Passe-fil		
12	5100051926	1	pc	Entlüftungsschlauch Línea de purgado	Breather tube Tuyau d'évacuation purge		
13	5000209719	1	pc	Anschlußnippel Boquilla de conexión	Connecting nipple Raccord fileté		
14	5000202465	1	pc	Schelle Abrazadera	Clamp Collier		
15	5000209871	1	pc	Wasserabscheider Kpl Separador de agua cpl.ua	Water separator cpl. Separateur d'eau cpl.		
16	5000202412	1	pc	Schlauch 20X12mm Manguera de combustible	Fuel hose Tuyau à essence	20 x 12	
17	5000108688	1	pc	Schlauchklemme Sujetador	Clip Agrafe		
18	5000209707	1	pc	Wasserabscheider Dispositivo para separar el agua	Water separator Purgeur de diesel-oil		
19	5000202461	1	pc	Schraube M10 Tornillo	Screw Vis	M10	
20	5000151530	2	pc	Sechskantmutter Contratuercas	Locknut Contre-écrou	M8	
21	5000151553	2	pc	Scheibe Arandela	Washer Rondelle	B8,4	ISO7089
22	5000108892	4	pc	Scheibe Disco	Disc Disque	8,2 x 22 x 2	
24	5000108895	2	pc	Hülse Manguito	Sleeve Douille		
25	5000151489	2	pc	Isolierrohr Kpl. Cuerda cpl.	Insulating pipe cpl. Tube isolant cpl.		
26	5000108893	1	pc	Halter Apoyo	Brace Ventrière		
27	5000108791	4	pc	Scheibe Disco	Disc Disque	7,1 x 17,9 x 2	
28	5000202347	2	pc	Sechskantschraube Tornillo hexagonal	Hexagonal head cap screw Vis à tête hexagonale	M6 x 20	
29	5000151526	2	pc	Stiftschraube Perno prisionero	Stud Boulon	M8 x 25	DIN825
30	5000108896	2	pc	Bügel Apoyo	Brace Ventrière		
32	5000151540	2	pc	Scheibe Arandela	Washer Rondelle	A6,4	DIN9021

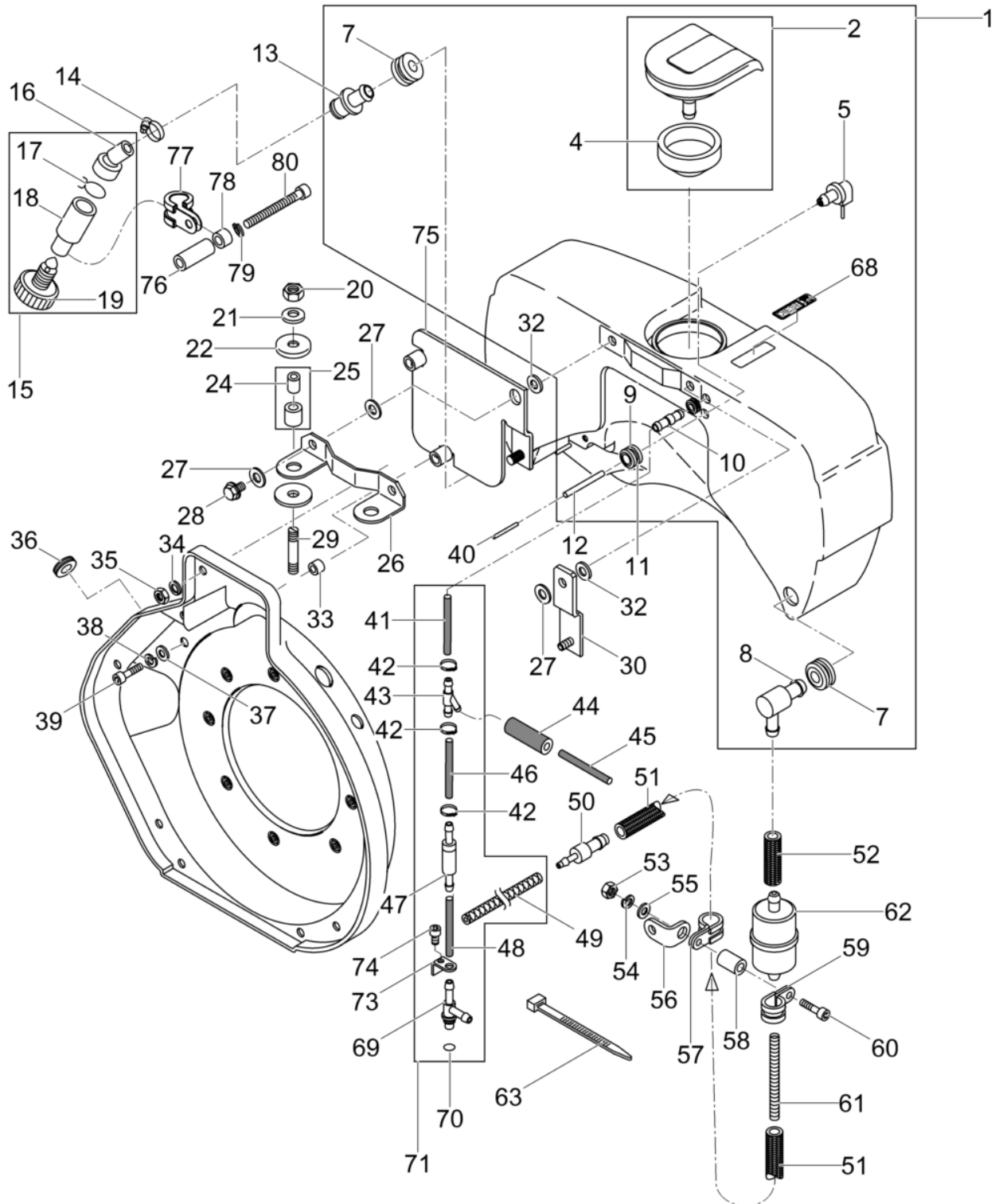

Pos. Item	Artikel Nr. Item no.	Pc.	Unit	Beschreibung Descripción	Description Description	Abm. Dim.	Norm Standard
						Drehmoment Torque	Schmierstoff Lubricant
33	5000108890	2	pc	Scheibe Arandela	Washer Rondelle	6,5 x 13 x 4,8	
34	5000151456	2	pc	Federring Arandela elástica	Lock washer Rondelle de ressort	6	DIN128
35	5000151323	2	pc	Sechskantmutter Contratuerca	Locknut Contre-écrou	M6	ISO4032
36	5000108889	2	pc	Gummitülle Casquillo de goma	Rubber funnel Passe fil en caoutchouc		
37	5000151324	2	pc	Scheibe Arandela	Washer Rondelle	6.4	
38	5000151456	2	pc	Federring Arandela elástica	Lock washer Rondelle de ressort	6	DIN128
39	5000151231	2	pc	Zylinderschraube Tornillo cilíndrico	Cheese head screw Vis à tête cylindrique	M6 x 16	ISO4762
40	5000108888	1	pc	Rohr Tubo	Pipe Tube	1,4 x 2 x 16	
41	5000209966	1	pc	Kraftstoffleitung Manguera de combustible	Fuel hose Tuyau à essence		
42	5000207586	2	pc	Schlauchklemme Abrazadera	Clamp Collier de serrage		
43	5000128959	1	pc	T-Schlauchnippel Boquilla para manguera en t	Tee-stem for hose Raccord de flexible t		
44	5000209716	1	pc	Schlauch Manguera de combustible	Fuel hose Tuyau à essence	7x25	
45	5000128968	1	pc	Kraftstoffleitung Tubería de combustible	Fuel pipe Tuyau à combustible	2,5 x 195	
46	5000207528	1	pc	Kraftstoffleitung Tubería de combustible	Fuel pipe Tuyau à combustible		
47	5000047977	1	pc	Ventil Unión	Hose fitting Raccord		
48	5100003877	1	pc	Kraftstoffleitung Tubería de combustible	Fuel pipe Tuyau à combustible		
49	5000095018	1	pc	Leitung Manguera	Hose Tuyau	160	
50	5000209876	1	pc	Nippel Boquilla roscada	Nipple Raccord fileté		
51	5100051925	1	pc	Kraftstoffschlauch Manguera de combustible	Fuel hose Tuyau à essence		
52	5100051924	1	pc	Kraftstoffschlauch Manguera de combustible	Fuel hose Tuyau à essence		
53	5000151323	1	pc	Sechskantmutter Contratuerca	Locknut Contre-écrou	M6	ISO4032
54	5000151456	1	pc	Federring Arandela elástica	Lock washer Rondelle de ressort	6	DIN128
55	5000151324	1	pc	Scheibe Arandela	Washer Rondelle	6.4	
56	5000209879	1	pc	Winkel Banda de retención	Retaining strap Sangle de fixation		
57	5000107451	1	pc	Schelle Abrazadera	Clamp Agrafe		
58	5000108852	1	pc	Hülse Tubo	Spacer tube Tube	6,5 x 12 x 18	
59	5000107451	1	pc	Schelle Abrazadera	Clamp Agrafe		
60	5000209880	1	pc	Zylinderschraube Tornillo cilíndrico	Cheese head screw Vis à tête cylindrique	M 6x40	

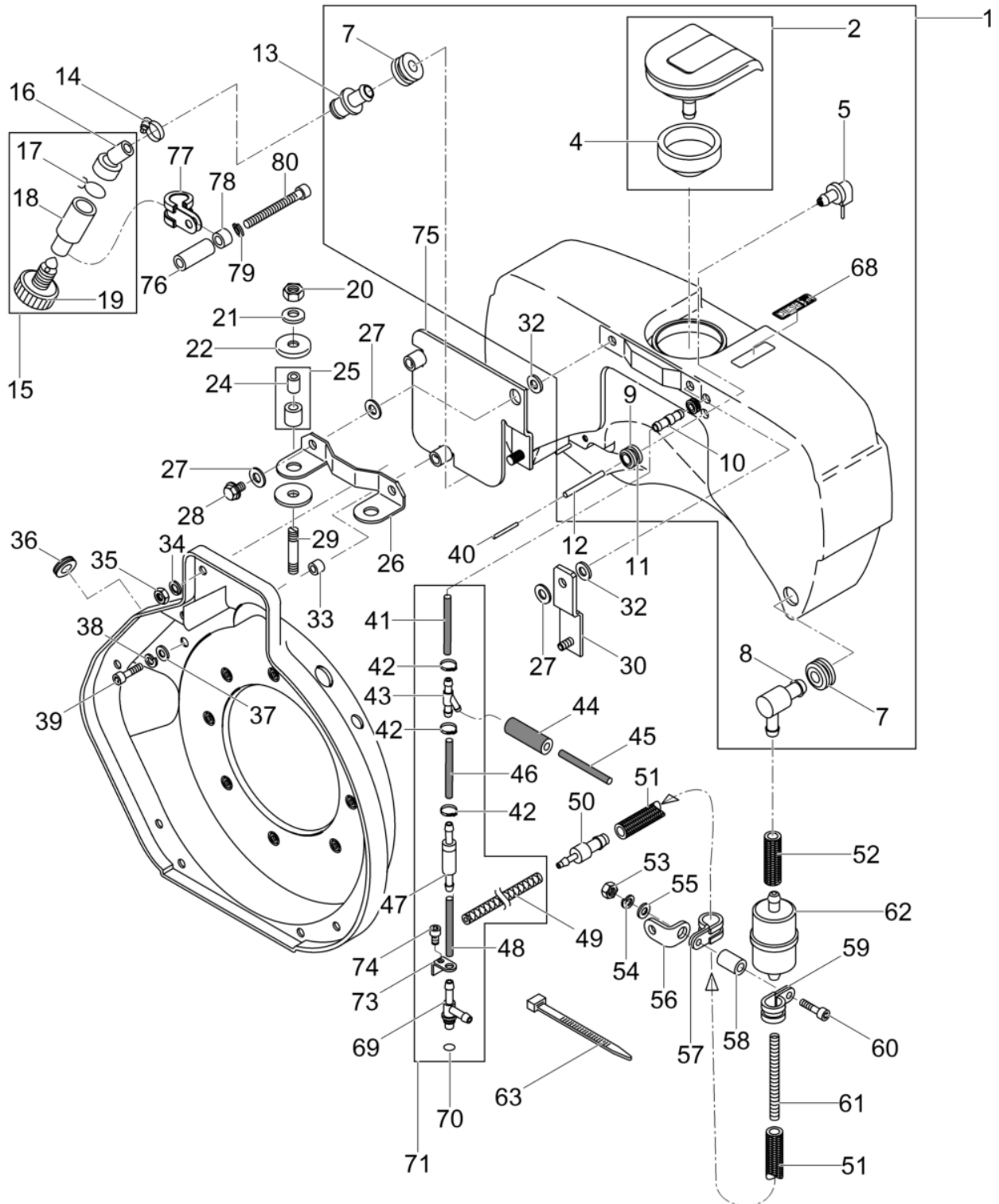

Pos. Item	Artikel Nr. Item no.	Pc.	Unit	Beschreibung Descripción	Description Description	Abm. Dim.	Norm Standard
						Drehmoment Torque	Schmierstoff Lubricant
61	5000106564	1	pc	Feder Resorte	Spring Ressort		
62	5100046186	1	pc	Dieselfilter-Einsatz Diesel cartucho filtrante	Diesel filter insert Diesel element filtrant		
63	5000109710	2	pc	Kabelbinder Fijación	Tie cable Attache		
68	5000129791	1	pc	Aufkleber-Diesel Calcomanía-diesel	Decal-diesel Autocollant-diesel		
69	5000209682	1	pc	T-Stück Pieza t	T-piece T-pièce		
70	5000071130	1	pc	O-Ring Anillo-o	O-ring Bague-o	7,5 x 10,5 x 1,5	
71	5000209968	1	pc	Kraftstoffleitung Kpl. Pipa del combustible cpl.	Fuel pipe cpl. Pipe du combustible cpl.		
73	5200022043	1	pc	Konsole Soporte	Bracket Support		
74	5000217620	1	pc	Zylinderschraube Tornillo cilíndrico	Cheese head screw Vis à tête cylindrique	M5x25	
75	5100051944	1	pc	Blech Kpl. Chapa cpl.	Plate cpl. Tôle cpl.		
76	5000054291	1	pc	Abstandsstück Espaciador	Spacer Entretoise		
77	5200022037	1	pc	Befestigung Clip	Clip Clip		
78	5100039000	1	pc	Buchse Buje	Bush Boîte		
79	5000151456	1	pc	Federring Arandela elástica	Lock washer Rondelle de ressort	6	DIN128
80	5100037722	1	pc	Zylinderschraube Tornillo cilíndrico	Cheese head screw Vis à tête cylindrique		

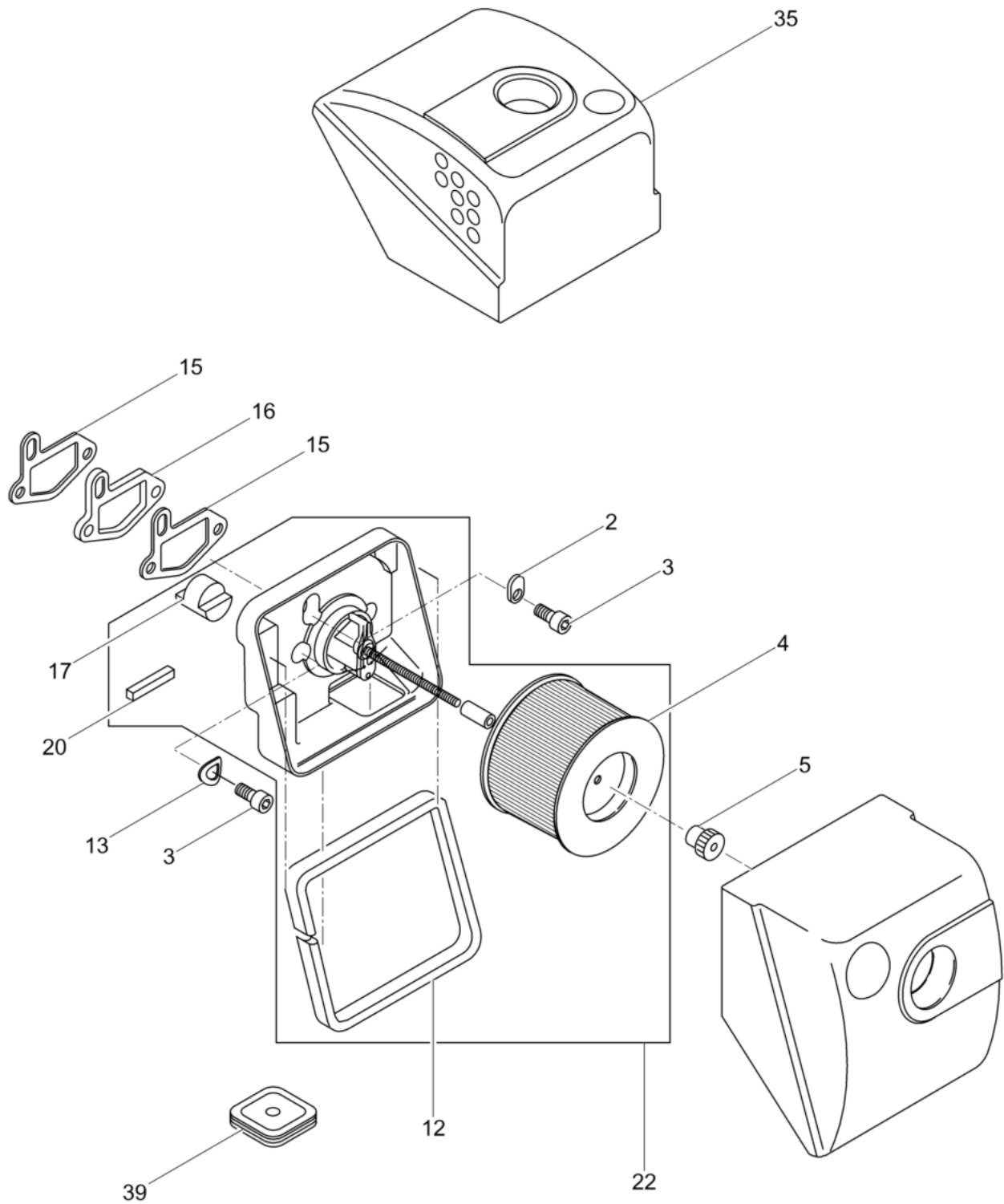

DPS1850H BASIC

Luffilter
Air cleaner
Filtro del aire
Filtre à air

Pos. Item	Artikel Nr. Item no.	Pc.	Unit	Beschreibung Descripción	Description Description	Abm. Dim.	Norm Standard
						Drehmoment Torque	Schmierstoff Lubricant
2	5000108902	1	pc	Scheibe Arandela	Washer Rondelle		
3	5000151559	3	pc	Zylinderschraube Tornillo cilíndrico	Cheese head screw Vis à tête cylindrique	M8 x 25	ISO4762
4	5000150924	1	pc	Filter Filtro	Filter Filtre		
5	5000108904	1	pc	Rändelmutter Tuerca	Nut Ecrou	M6	
12	5000129013	1	pc	Dichtleiste Empaque	Seal Joint		
13	5200022048	2	pc	Tellerfeder Arandela de resorte	Spring washer Ressort belleville	A8	
15	5000108897	2	pc	Dichtung Junta	Gasket Joint		
16	5000108898	1	pc	Isolierflansch Brida	Flange Collerette		
17	5000108899	1	pc	Stopfen Tapón	Push-in plug Bouchon		
20	5000151532	1	pc	Dichtleiste Empaque	Seal Joint	14 x 9 x 30	
22	5100016574	1	pc	Filtergehäuse Kpl. Caja del filtro compl.	Air filter housing cpl. Boîtier de filtre compl.		
35	5000209970	1	pc	Luffilterdeckel Tapa filtro de aire	Air filter cover Couvercle filtre à air		
39	5000202308	1	pc	Verschlussdeckel Tapa del tanque de combustible	Fuel tank cap Chapeau de réservoir à essence		



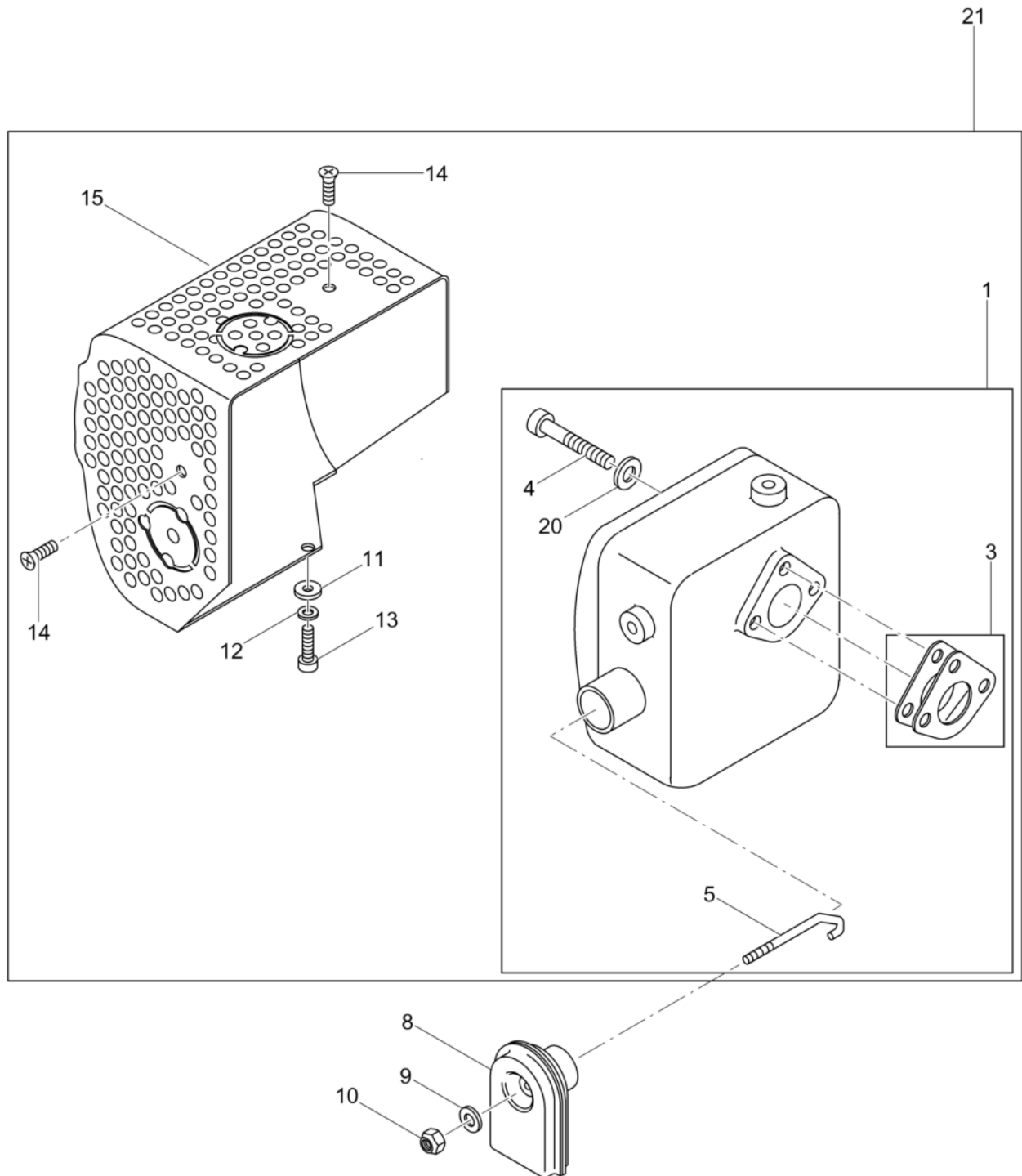

DPS1850H BASIC

Abgasdämpfer Exhaust silencer Silenciador Silencieux

Pos. Item	Artikel Nr. Item no.	Pc.	Unit	Beschreibung Descripción	Description Description	Abm. Dim.	Norm Standard
						Drehmoment Torque	Schmierstoff Lubricant
1	5000214968	1	pc	Abgasdämpfer Silenciador	Exhaust silencer Silencieux		
3	5000215773	1	pc	Dichtungspaket Junta	Gasket Joint		
4	5000202457	3	pc	Innensechskantschraube Tornillo a seis lados huecos	Hexagon socket head screw Vis à six pans creux	M8 x 25	
5	5000206629	1	pc	Gewindebolzen Perno roscado	Threaded bolt Boulon fileté	M6	
8	5000129032	1	pc	Auspuffkrümmer Mit Sieb Codo de escape con filtro	Exhaust manifold with screen Collecteur d'échappement avec		
9	5000151324	1	pc	Scheibe Arandela	Washer Rondelle	6,4	
10	5100038999	1	pc	Sechskantmutter M6 Tuerca hexagonal	Hexagon nut Écrou hexagonal		
11	5000107401	1	pc	Scheibe Arandela	Washer Rondelle	6,4	
12	5000151456	1	pc	Federring Arandela elástica	Lock washer Rondelle de ressort	6	DIN128
13	5000202338	1	pc	Sechskantschraube Tornillo hexagonal	Hexagonal head cap screw Vis à tête hexagonale	M6 x 16	DIN933
14	5000151387	2	pc	Senkschraube Tornillo avellanado	Countersunk screw Vis noyée	M6 x 12 14Nm/10ft.lbs	ISO10642
15	5000214969	1	pc	Berührungsschutz Dispositivo de protección	Contact safety device Grille de protection		
20	5000151218	3	pc	Federring Arandela elástica	Lock washer Rondelle de ressort	8	
21	5000214967	1	pc	Abgasdämpfer Satz Silenciador juego	Exhaust silencer kit Silencieux jeu		



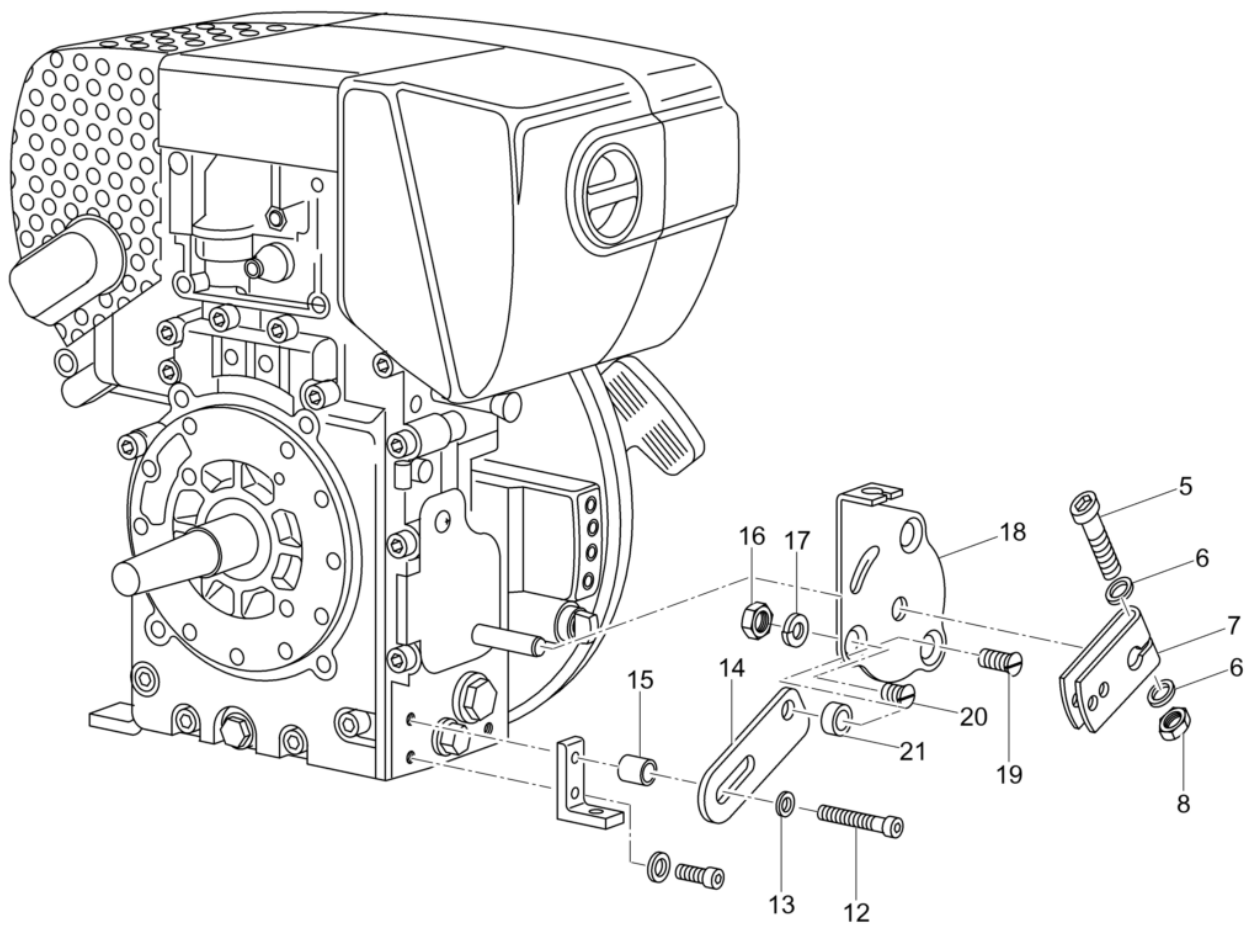

Pos. Item	Artikel Nr. Item no.	Pc.	Unit	Beschreibung Descripción	Description Description	Abm. Dim.	Norm Standard
						Drehmoment Torque	Schmierstoff Lubricant
5	5000209886	1	pc	Zylinderschraube Tornillo cilíndrico	Cheese head screw Vis à tête cylindrique	M 5x30	
6	5000129517	2	pc	Scheibe Arandela	Washer Rondelle	A5,3	ISO7089
7	5000109717	1	pc	Hebel Palanca	Lever Levier		
8	5000129020	1	pc	Sechskantmutter Contratuerca	Locknut Contre-écrou	M5	ISO4032
12	5000126979	1	pc	Zylinderschraube Tornillo cilíndrico	Cheese head screw Vis à tête cylindrique	M8 x 60	DIN912
13	5000151553	1	pc	Scheibe Arandela	Washer Rondelle	B8,4	ISO7089
14	5000126980	1	pc	Lasche Eclisa	Plate Attache		
15	5000107843	1	pc	Hülse Manguito	Sleeve Douille		
16	5000129021	1	pc	Sechskantmutter Contratuerca	Locknut Contre-écrou	VM6	
17	5000151218	1	pc	Federring Arandela elástica	Lock washer Rondelle de ressort	8	
18	5000209887	1	pc	Konsole Consola	Console Console		
19	5000126982	1	pc	Senkschraube Tornillo avellanado	Countersunk screw Vis noyée	M6 x 20 14Nm/10ft.lbs	ISO10642
20	5000129022	1	pc	Senkschraube Tornillo avellanado	Countersunk screw Vis noyée	M6 x 16 14Nm/10ft.lbs	ISO10642
21	5000063384	1	pc	Zwischenstück Pieza intermedia	Adaptor Pièce intermédiaire		

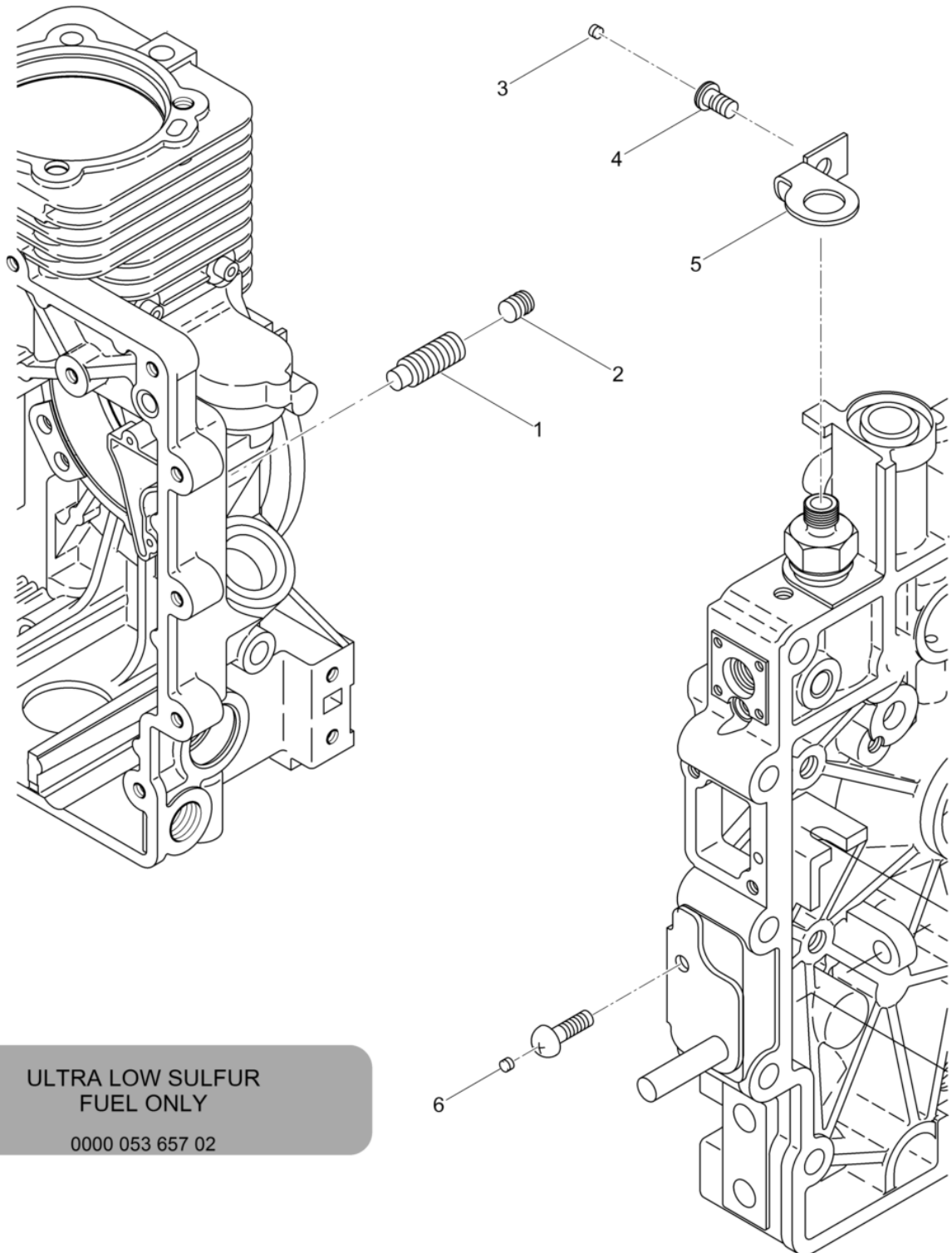

ULTRA LOW SULFUR
FUEL ONLY

0000 053 657 02

7

DPS1850H BASIC**Motorausrüstung EPA
Engine equipment epa
Equipamiento de motor epa
Equipement moteur epa**

Pos. Item	Artikel Nr. Item no.	Pc.	Unit	Beschreibung Descripción	Description Description	Abm. Dim.	Norm Standard
						Drehmoment Torque	Schmierstoff Lubricant
1	5100051930	1	pc	Gewindestift Varilla roscada	Threaded pin Goupille fileté		
2	5100051928	1	pc	Stopfen Tapón	Plug Bouchon		
3	5000151513	1	pc	Stopfen Tapón	Push-in plug Bouchon		
4	5000126983	1	pc	Flachkopfschraube Tornillo de cabeza plana	Pan head screw Vis lentiforme	M6 x 12 14Nm/10ft.lbs	DIN7380
5	5000209695	1	pc	Deckel Tapa	Cover Couvercle		
6	5000151522	1	pc	Verschlussstopfen Tapón	Push-in plug Bouchon		
7	5100051922	1	pc	Aufkleber Calcomania	Label Autocollant		



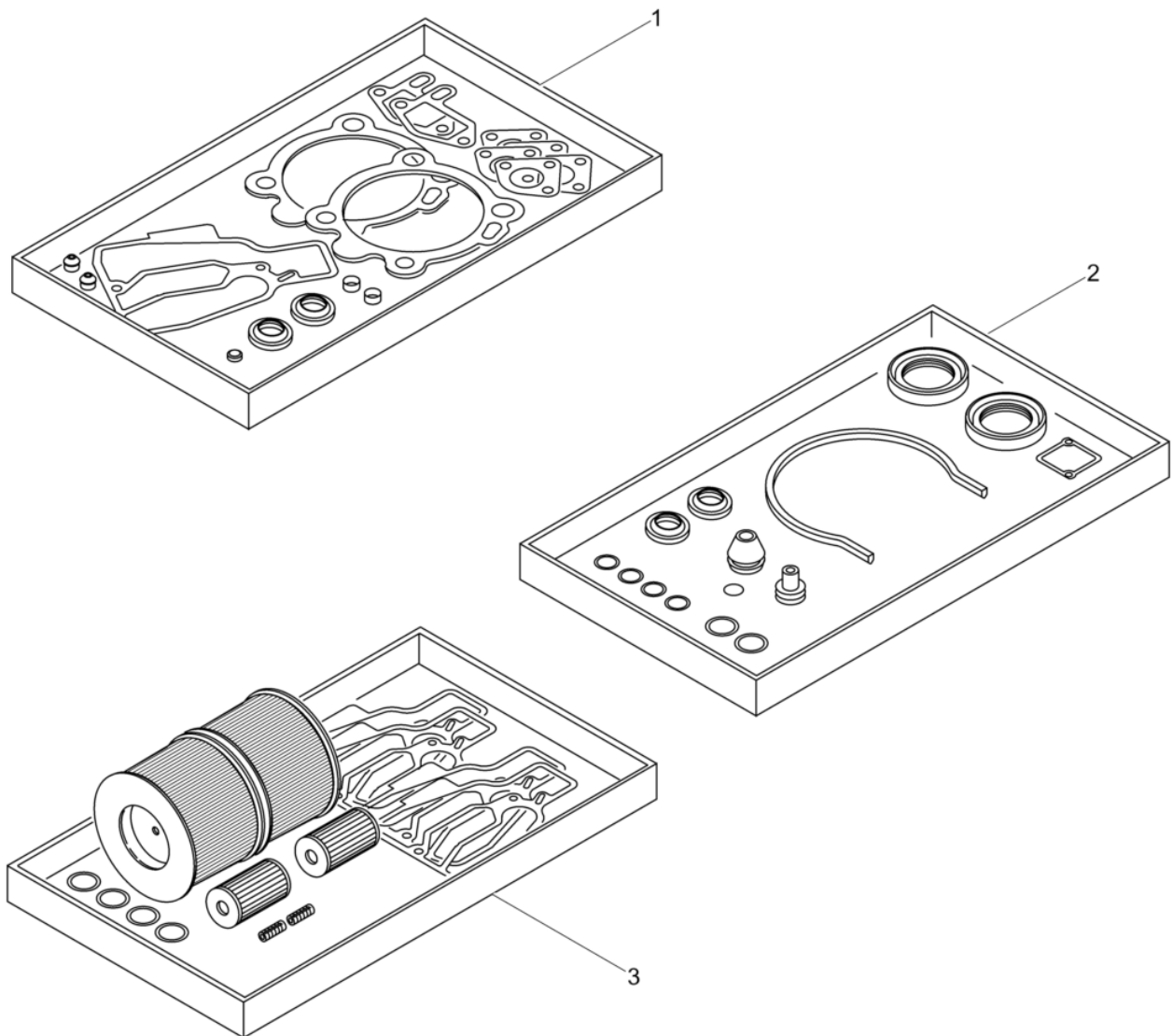

DPS1850H BASIC**Ersatzteilsätze
Spare parts kits
Juegos de repuestos
Jeu de pièces de rechange**

Pos. Item	Artikel Nr. Item no.	Pc.	Unit	Beschreibung Descripción	Description Description	Abm. Dim.	Norm Standard
						Drehmoment Torque	Schmierstoff Lubricant
1	5000108697	1	pc	Dichtungssatz-Zylinderkopf Juego de juntas-culata de cilindro	Set-gasket, cylinder head Jeu de joints-culasse de		
2	5000108698	1	pc	Dichtungssatz Juego de juntas	Gasket set Jeu de joints		
3	5100051951	1	pc	Wartungssatz Juego para mantenimiento	Maintenance set Jeu d'entretien		



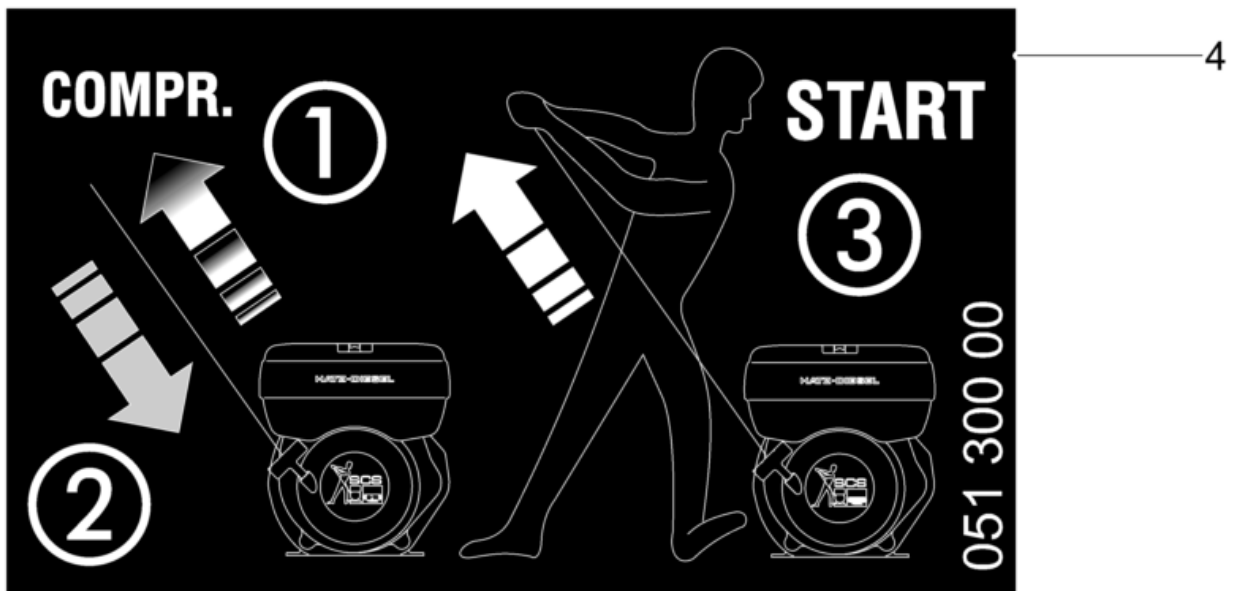

DPS1850H BASIC**Zubehör
Accessories
Accesorios
Accessoires**

Pos. Item	Artikel Nr. Item no.	Pc.	Unit	Beschreibung Descripción	Description Description	Abm. Dim.	Norm Standard
						Drehmoment Torque	Schmierstoff Lubricant
4	5100001086	1	pc	Aufkleber-Hinweis Starten Autoadhesivo nota de arranque	Starting note decal Autocollants appliquer consign		



Gleitvorrichtung Kpl. PGV 1850
Urethane pad kit cpl. pgv 1850
Placa de deslizamiento cpl. pgv 1850
Jeu de tapis en polyuréthane

DPS1850H BASIC

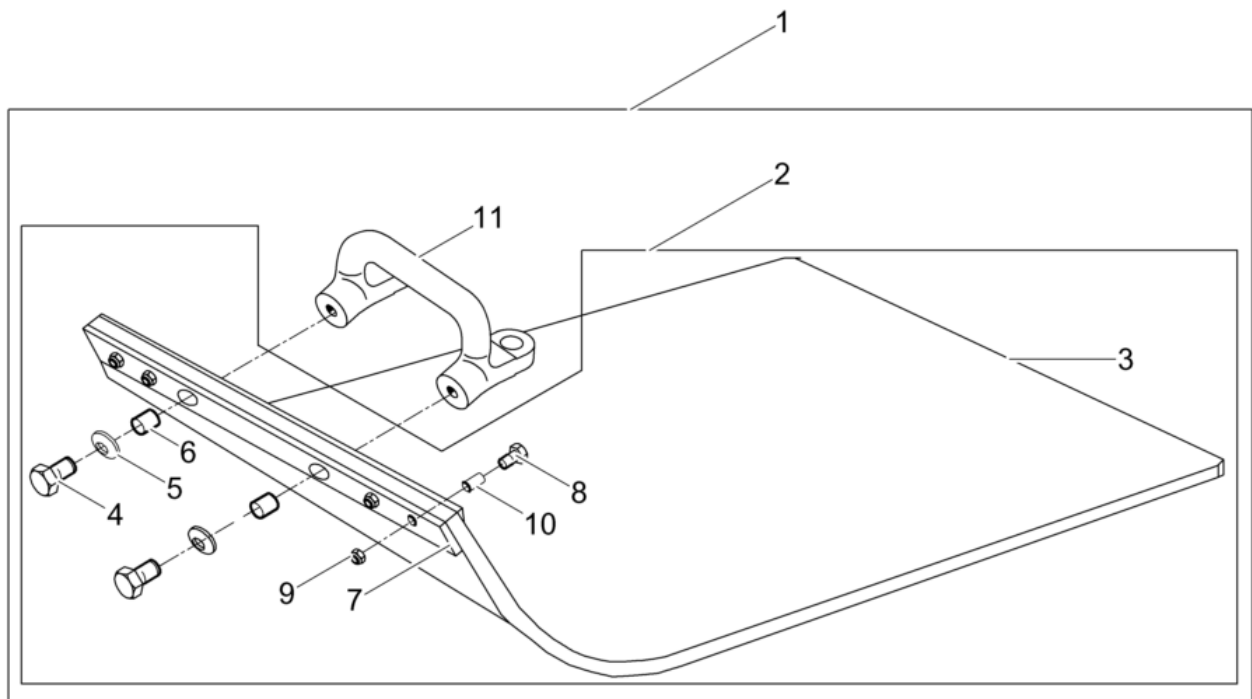

DPS1850H BASIC
**Gleitvorrichtung Kpl. PGV 1850
Urethane pad kit cpl. pgv 1850
Placa de deslizamiento cpl. pgv 1850
Jeu de tapis en polyuréthane**

Pos. Item	Artikel Nr. Item no.	Pc.	Unit	Beschreibung Descripción	Description Description	Abm. Dim.	Norm Standard
						Drehmoment Torque	Schmierstoff Lubricant
1	5000201905	1	pc	Gleitvorrichtung Placa de deslizamiento pgv 1850	Urethane pad kit pgv 1850 Jeu de tapis en polyuréthane		
2	5000069095	1	pc	Gleitvorrichtung Placa de deslizamiento pgv 50	Urethane pad kit pgv 50 Jeu de tapis en polyuréthane		
3	5000047584	1	pc	Kunststoffplatte Juego de lamina de uretano	Urethane plate Dispositif de glissement		
4	5000011421	2	pc	Sechskantschraube Tornillo hexagonal	Hexagonal head cap screw Vis à tête hexagonale	M12 x 40 86Nm/63ft.lbs	DIN933
5	5000031565	2	pc	Spannscheibe Arandela elástica	Lockwasher Rondelle de ressort	12	DIN6796
6	5000047578	2	pc	Buchse Buje	Bushing Douille		
7	5000047574	2	pc	Befestigungsleiste Listón de sujeción	Fitting Listeau de fixation		
8	5000011456	4	pc	Sechskantschraube Tornillo hexagonal	Hexagonal head cap screw Vis à tête hexagonale	25Nm/18ft.lbs	
9	5000033356	4	pc	Sechskantmutter Tuerca hexagonal	Hexagon nut Écrou hexagonal		
10	5000047577	4	pc	Buchse Buje	Bushing Douille		
11	5000069893	1	pc	Handgriff Empuñadura	Handle Poignée		



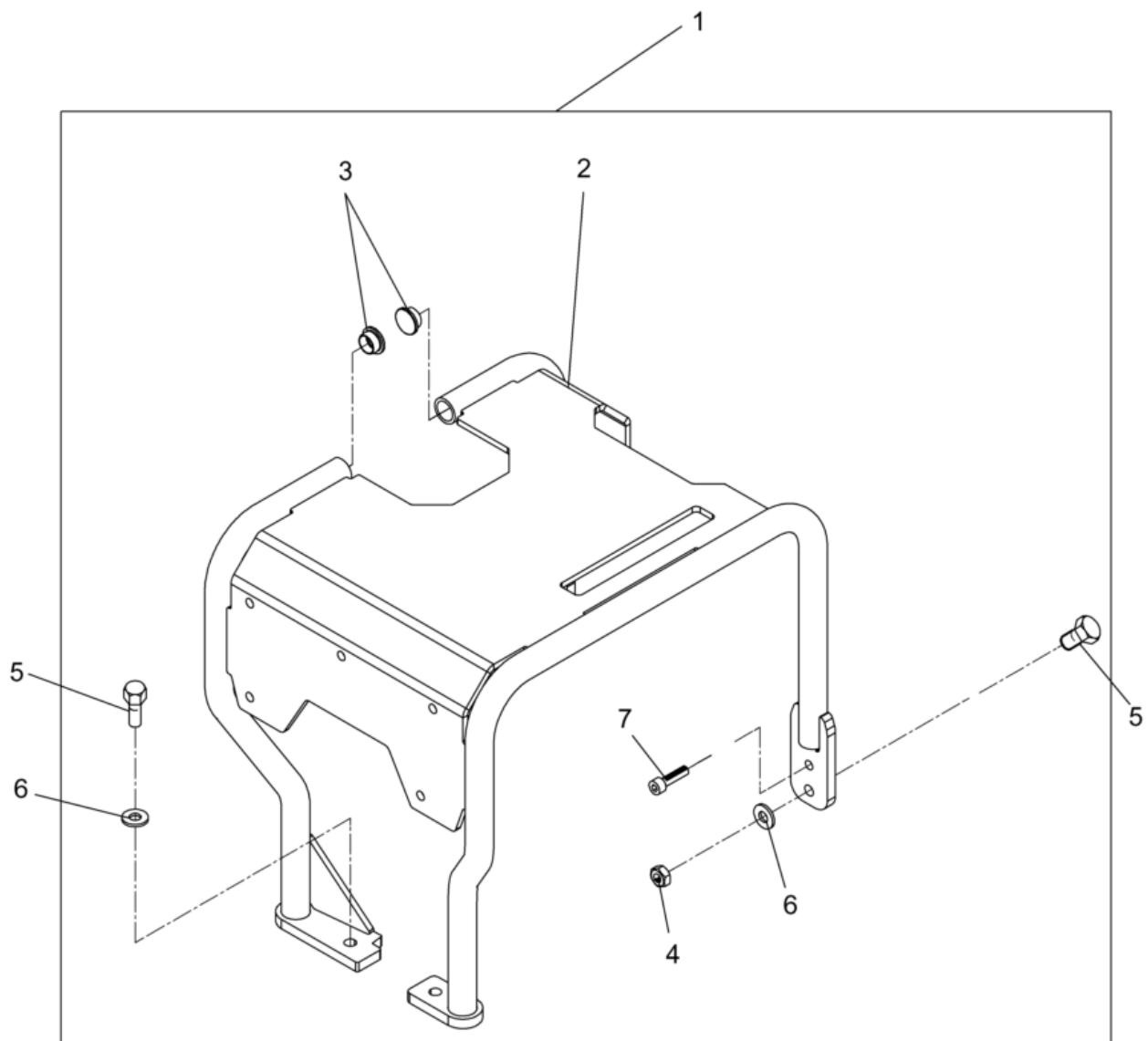

DPS1850H BASIC**Schutzrahmen Kpl.
Protective frame cpl.
Placca de proteccón cpl.
Cadre protection cpl.**

Pos. Item	Artikel Nr. Item no.	Pc.	Unit	Beschreibung Descripción	Description Description	Abm. Dim.	Norm Standard
						Drehmoment Torque	Schmierstoff Lubricant
1	5000201978	1	pc	Schutzrahmen Kpl. Placca de proteccón cpl.	Protective frame cpl. Cadre protection cpl.		
2	5000201594	1	pc	Schutzrahmen Armazón de proteccón	Protective frame Cadre protection		
3	5000201891	2	pc	Verschlussstopfen Tapón de cierre	Locking plug Bouchon de fermeture		
4	5000010883	2	pc	Sechskantmutter Tuerca hexagonal	Hexagon nut Écrou hexagonal		
5	5000011439	4	pc	Sechskantschraube Tornillo hexagonal	Hexagonal head cap screw Vis à tête hexagonale	49Nm/36ft.lbs	
6	5000033988	4	pc	Spannscheibe Arandela elástica	Lockwasher Rondelle de ressort	10	DIN6796
7	5000011542	2	pc	Zylinderschraube Tornillo cilíndrico	Cheese head screw Vis à tête cylindrique	25Nm/18ft.lbs	



Fahrgestell Kpl.
Trolley cpl.
Dispositivo de transporte cpl.
Chassis cpl.

DPS1850H BASIC

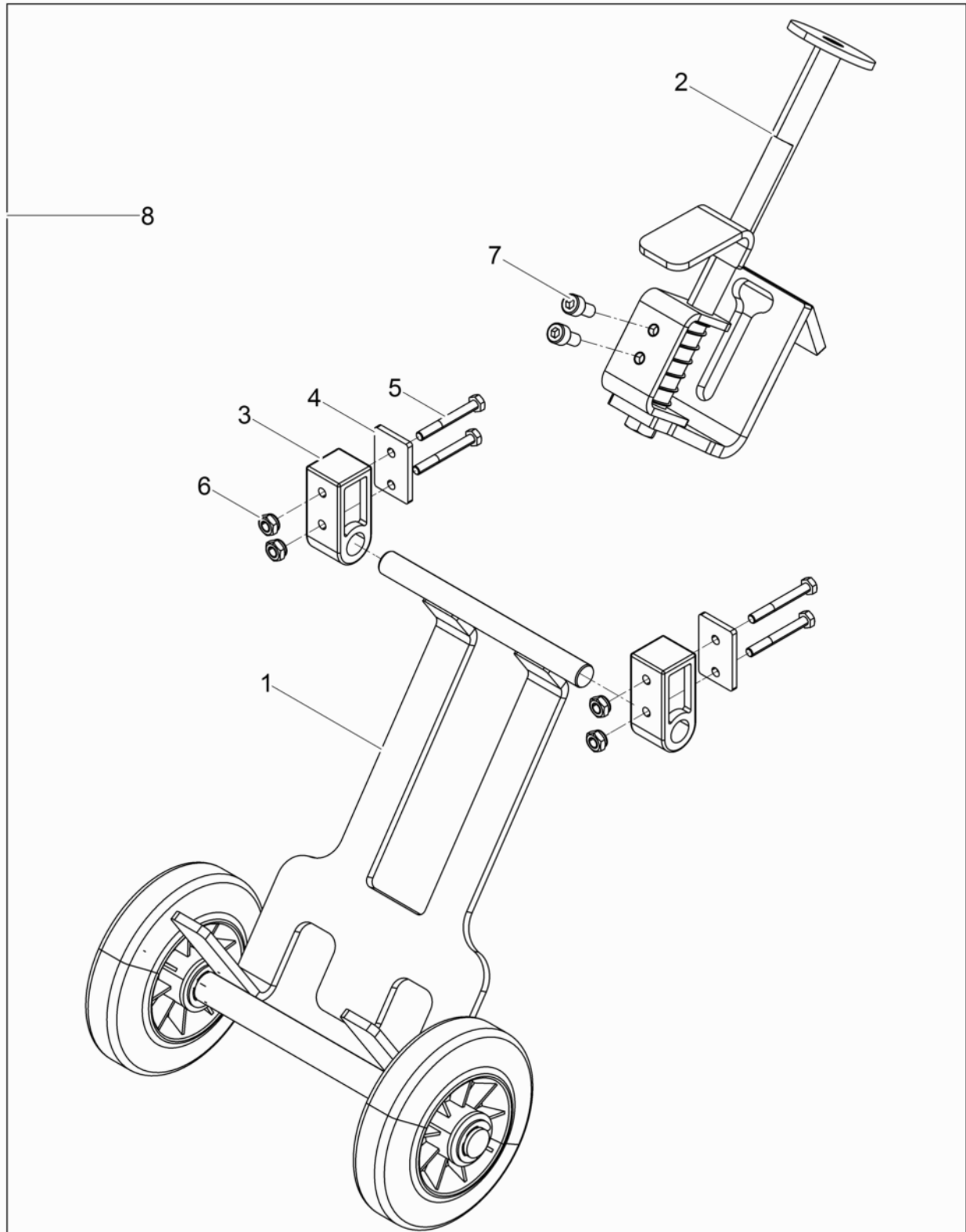

DPS1850H BASIC

Fahrgestell Kpl.
Trolley cpl.
Dispositivo de transporte cpl.
Chassis cpl.

Pos. Item	Artikel Nr. Item no.	Pc.	Unit	Beschreibung Descripción	Description Description	Abm. Dim.	Norm Standard
						Drehmoment Torque	Schmierstoff Lubricant
1	5000108248	1	pc	Fahrgestell Dispositivo de transporte	Trolley Chassis		
2	5000108249	1	pc	Arretierung Kpl. Dispositivo de retención cpl.	Lock cpl. Dispositif d'arrêt cpl.		
3	5000108286	2	pc	Halterung Soporte	Fixing device Bague de retenue		
4	5000108256	2	pc	Leiste Listón	Bar Listeau		
5	5000011331	4	pc	Sechskantschraube Tornillo hexagonal	Hexagonal head cap screw Vis à tête hexagonale	M6 x 50 10Nm/7ft.lbs	DIN931
6	5000010368	5	pc	Sechskantmutter Tuerca hexagonal	Hexagon nut Écrou hexagonal	M6	DIN985
7	5000011544	2	pc	Zylinderschraube Tornillo cilíndrico	Cheese head screw Vis à tête cylindrique	M8 x 16 25Nm/18ft.lbs	ISO4762
8	5000201979	1	pc	Fahrgestell Kpl. Dispositivo de transporte cpl.	Trolley cpl. Chassis cpl.		



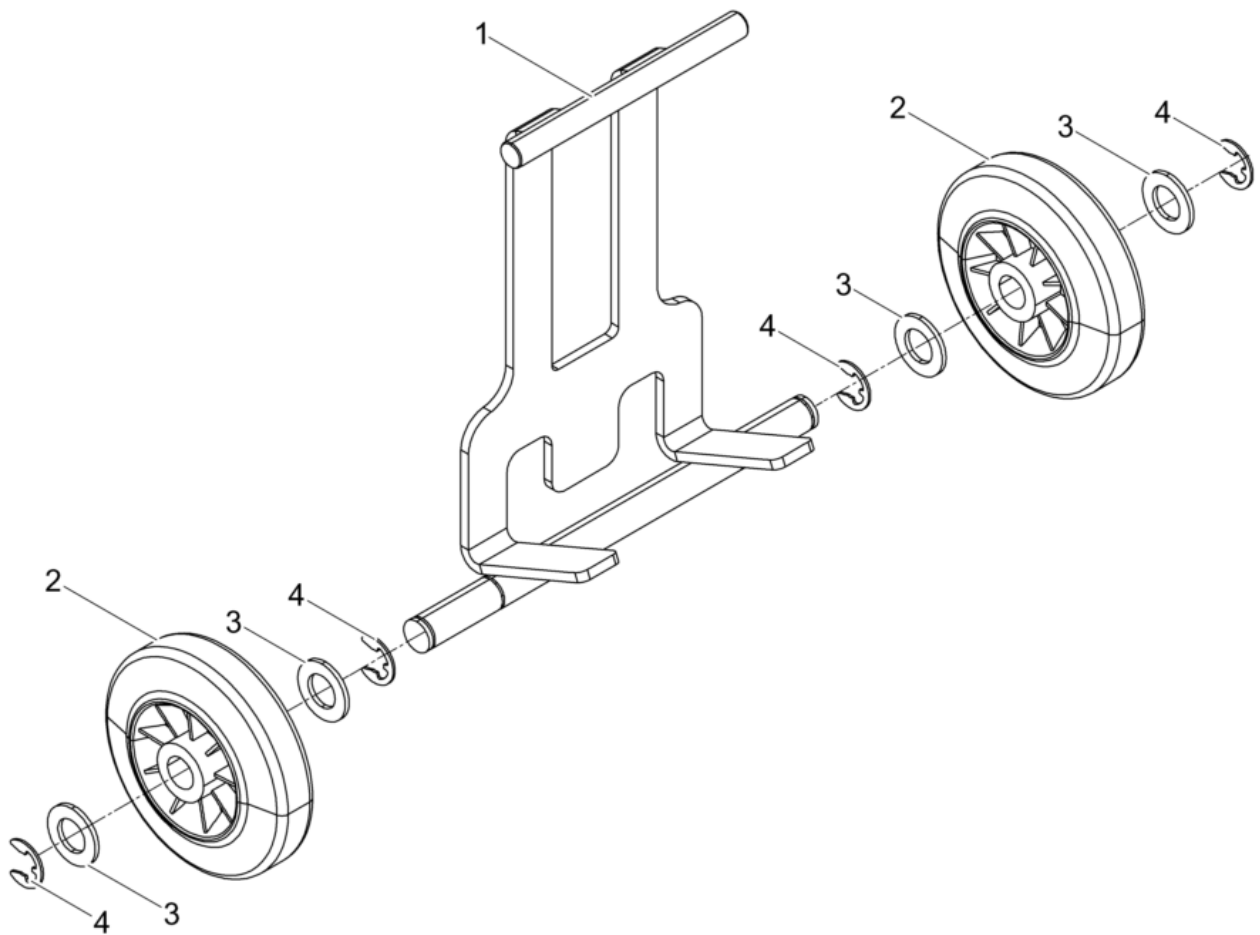

Pos. Item	Artikel Nr. Item no.	Pc.	Unit	Beschreibung Descripción	Description Description	Abm. Dim.	Norm Standard
						Drehmoment Torque	Schmierstoff Lubricant
1	5000108259	1	pc	Fahrgestell Dispositivo de transporte	Trolley Chassis		
2	5000021466	2	pc	Rad Rueda	Tire Roue	140 x 37,5	
3	5000010616	4	pc	Scheibe Arandela	Flat washer Rondelle		
4	5000103834	4	pc	Sicherungsscheibe Arandela de seguridad	Lock washer Rondelle d'arrêt	15	DIN6799

Arretierung Kpl.
Lock cpl.
Dispositivo de retención cpl.
Dispositif d'arrêt cpl.

DPS1850H BASIC

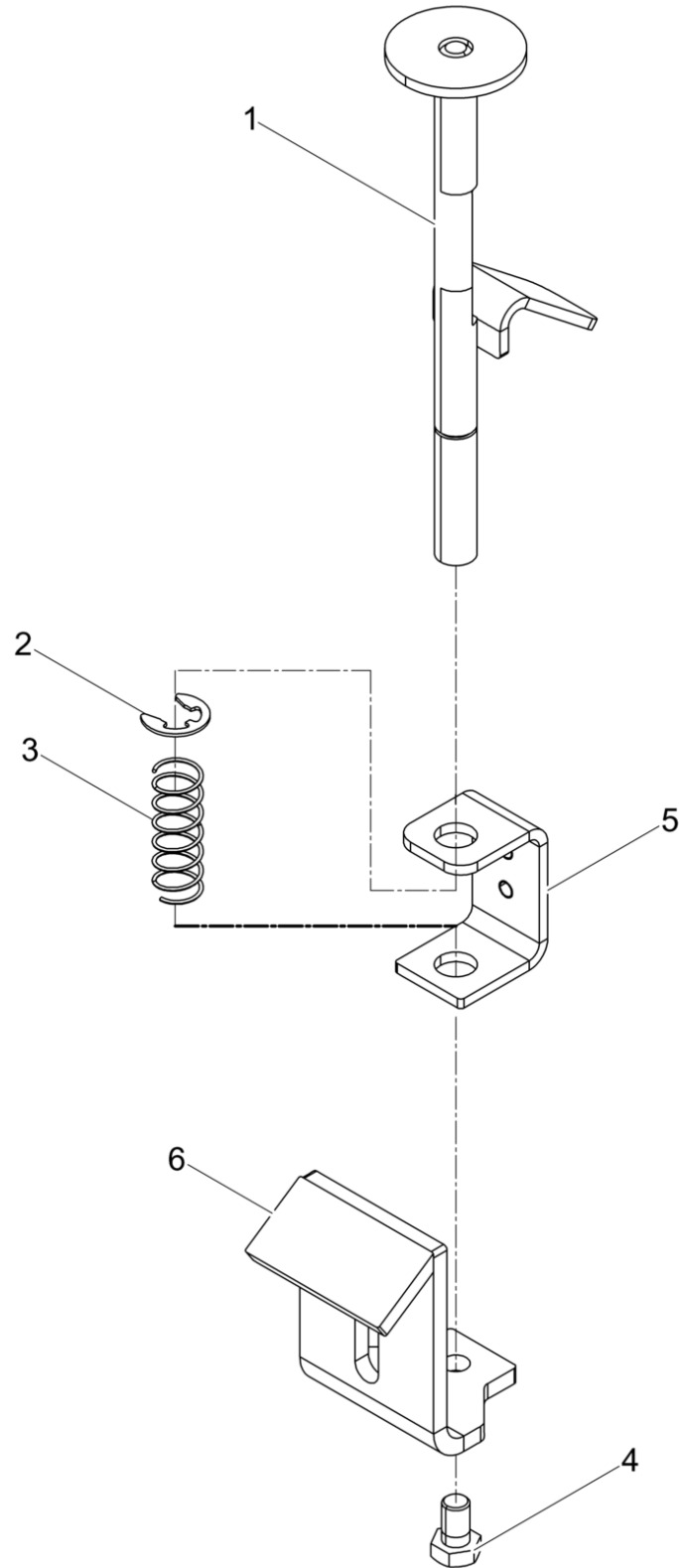

DPS1850H BASIC

Arretierung Kpl.
Lock cpl.
Dispositivo de retención cpl.
Dispositif d'arrêt cpl.

Pos. Item	Artikel Nr. Item no.	Pc.	Unit	Beschreibung Descripción	Description Description	Abm. Dim.	Norm Standard
						Drehmoment Torque	Schmierstoff Lubricant
1	5000208263	1	pc	Arretierung Dispositivo de retención	Lock Dispositif d'arrêt		
2	5000103834	1	pc	Sicherungsscheibe Arandela de seguridad	Lock washer Rondelle d'arrêt	15	DIN6799
3	5000033477	1	pc	Druckfeder Resorte de compresión	Compression spring Ressort de pression	D-210	DIN2098
4	5000012368	1	pc	Sechskantschraube Tornillo hexagonal	Hexagonal head cap screw Vis à tête hexagonale	M12 x 20 86Nm/63ft.lbs	DIN933
5	5000208264	1	pc	Halterung Soporte	Fixing device Bague de retenue		
6	5000108312	1	pc	Winkel Ángulo	Angle Coude		



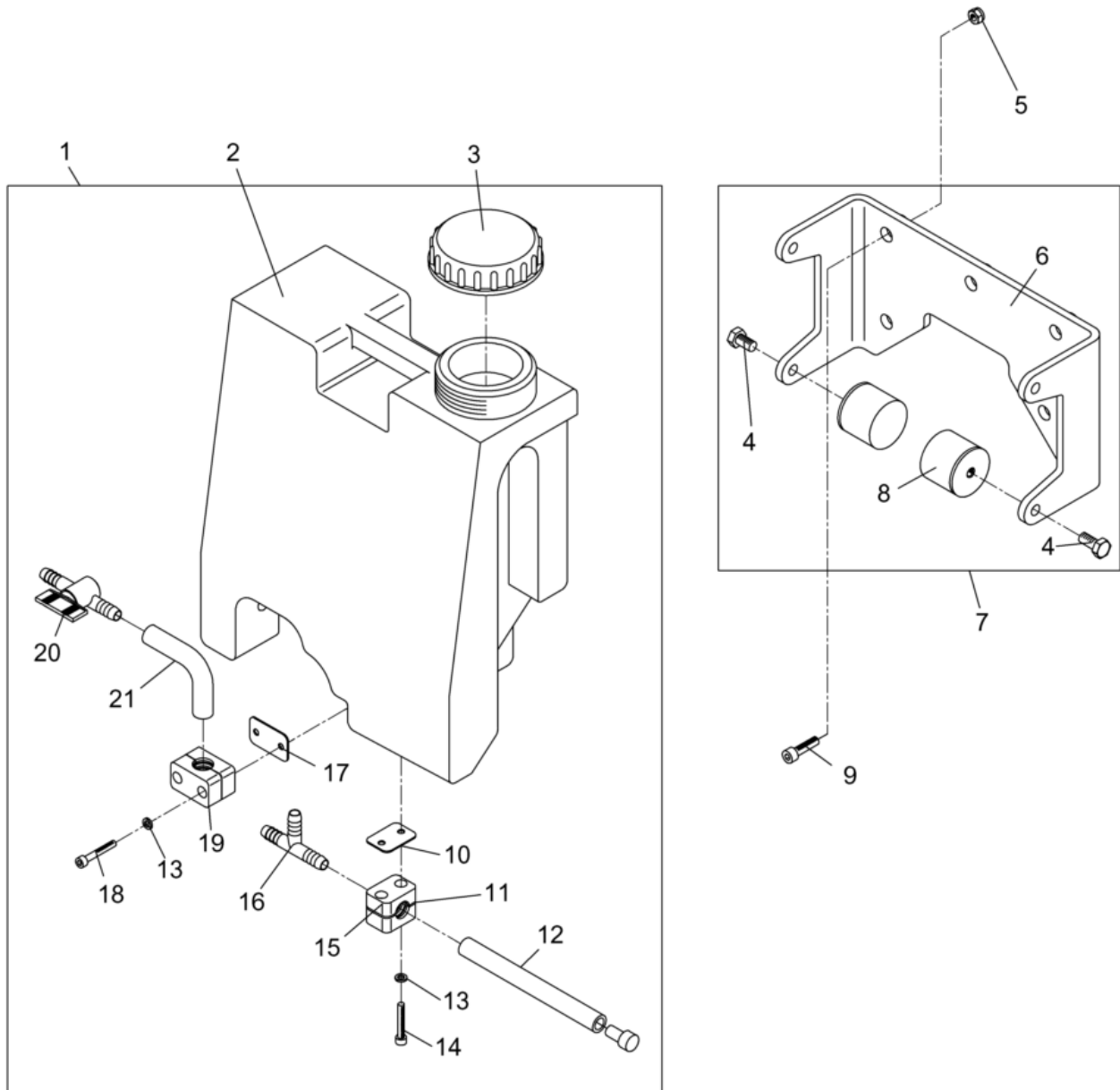

Pos. Item	Artikel Nr. Item no.	Pc.	Unit	Beschreibung Descripción	Description Description	Abm. Dim.	Norm Standard
						Drehmoment Torque	Schmierstoff Lubricant
1	5000104044	1	pc	Wassertank Kpl. Tanque de agua cpl.	Watertank cpl. Reservoir à eaú cpl.		
2	5000102864	1	pc	Wassertank Tanque de agua	Watertank Reservoir à eaú		
3	5000068351	1	pc	Schraubdeckel Tapa roscable	Screwed cover Couvercle fileté		
4	5000032175	4	pc	Sechskantschraube Tornillo hexagonal	Hexagonal head cap screw Vis à tête hexagonale	M10 x 18 49Nm/36ft.lbs	DIN933
5	5000010367	5	pc	Sechskantmutter Tuerca hexagonal	Hexagon nut Écrou hexagonal	M8	DIN985
6	5000201821	1	pc	Halterung Soporte	Fixing device Bague de retenue		
7	5000106066	1	pc	Halterung Kpl. Soporte cpl.	Fixing device cpl. Bague de retenue cpl.		
8	5000105969	4	pc	Anschlagpuffer Amortiguador	Shockmount Silentbloc		
9	5000011541	5	pc	Zylinderschraube Tornillo cilíndrico	Cheese head screw Vis à tête cylindrique	25Nm/18ft.lbs	
10	5000103546	2	pc	Leiste Listón	Bar Listeau		
11	5000103548	4	pc	Distanzplatte Placa distanciador	Distance plate Plaque d'écartement		
12	5000104043	2	pc	Düsenrohr Tubo a gicleur	Jet tube Tube à gicleur		
13	5000010744	6	pc	Scheibe Arandela	Washer Rondelle	6,4	DIN433
14	5000011548	4	pc	Zylinderschraube Tornillo cilíndrico	Cheese head screw Vis à tête cylindrique	10Nm/7ft.lbs	
15	5000103551	2	pc	Stauff-Standardschelle Abrazadera standard	Standard clamp Collier standard		
16	5000104041	1	pc	T-Stück Pieza t	T-piece T-pièce		
17	5000103545	1	pc	Leiste Listón	Bar Listeau		
18	5000011547	2	pc	Zylinderschraube Tornillo cilíndrico	Cheese head screw Vis à tête cylindrique	10Nm/7ft.lbs	
19	5000103552	1	pc	Stauff-Standardschelle Abrazadera standard	Standard clamp Collier standard		
20	5000103550	1	pc	Durchlaufhahn Grifo angular	Angular tap Robinet angulaire		
21	5000103986	1	pc	Schlauch Manguera	Hose Tuyau		
22	5000103553	2	pc	Verschlussstopfen Tapón de cierre	Locking plug Bouchon de fermeture		

Handgriff Kpl.
Handle complete
Manija compl.
Poignée compl.

DPS1850H BASIC

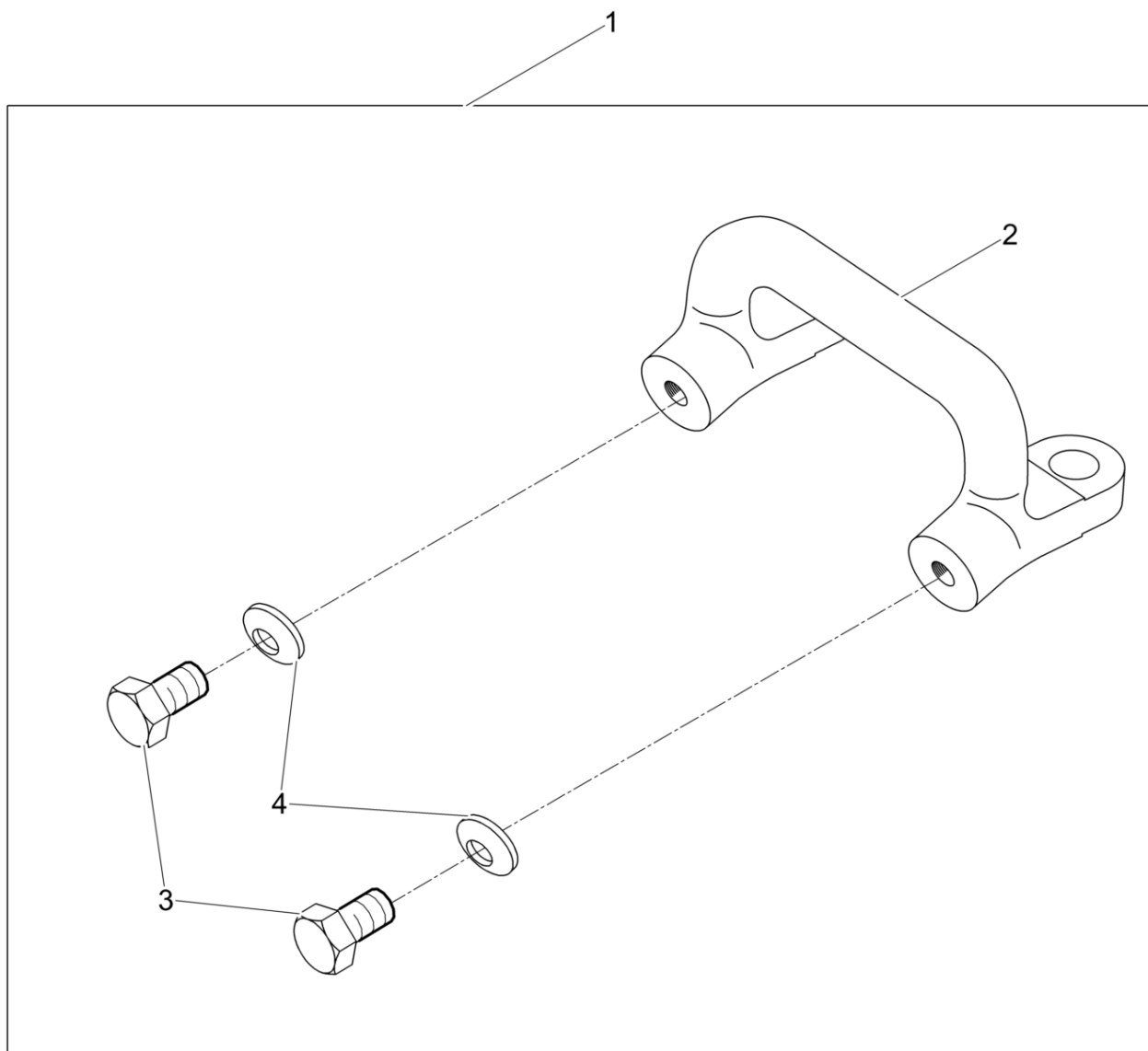

DPS1850H BASIC**Handgriff Kpl.
Handle complete
Manija compl.
Poignée compl.**

Pos. Item	Artikel Nr. Item no.	Pc.	Unit	Beschreibung Descripción	Description Description	Abm. Dim.	Norm Standard
						Drehmoment Torque	Schmierstoff Lubricant
1	5000204531	1	pc	Handgriff Kpl. Manija compl.	Handle complete Poignée compl.		
2	5000069893	1	pc	Handgriff Empuñadura	Handle Poignée		
3	5000011421	2	pc	Sechskantschraube Tornillo hexagonal	Hexagonal head cap screw Vis à tête hexagonale	M12 x 40 86Nm/63ft.lbs	DIN933
4	5000031565	2	pc	Spannscheibe Arandela elástica	Lockwasher Rondelle de ressort	12	DIN6796





**WACKER
NEUSON**

