



MASALTA[®]



OPERATION MANUAL RIDE-ON POWER TROWEL MRT364



WARNING

To reduce the risk of injury, all operators and maintenance personnel must read and understand these instructions before operating, changing accessories, or performing maintenance on Masalta power equipment. All possible situations cannot be covered in these instructions. Care must be exercised by everyone using, Maintaining or working near this equipment.

Table of Contents

1. SAFETY INFORMATION	2
1.1 Operating Safety.....	2
1.2 Operator Safety while using Internal Combustion Engines.....	2
1.3 Label Locations.....	3
1.4 Safety and Operating Labels.....	4-5
2. OPERATION	6
2.1 Control.....	6
2.2 Operating Principle	6
2.3 Delivery Checks	7
2.4 Before Starting.....	7
2.5 To Start	7
2.6 To Stop	8
2.7 Operation.....	8
2.8 Steering.....	8
2.9 Pitch Adjustment.....	8
3. MAINTENANCE	9
3.1 Periodic Maintenance Schedule.....	9
3.2 Trowel Gearbox.....	9
3.3 Lubrication.....	10
3.4 Transporting Trowels.....	10
3.5 Spark Plug.....	10
3.6 Air Filter.....	11
3.7 Trouble Shooting.....	11
4. TECHNICAL DATA	12
WARRANTY	13
MAINTENANCE RECORD	14
EC DECLARATION	15

SAFETY INFORMATION

1.1 Operating Safety

- NEVER operate this machine in application for which it is not intended.
- NEVER allow anyone to operate this equipment without proper training. People operating this equipment must be familiar with the risks and hazards associated with it.
- NEVER operate this unit without all guards in place. Keep hands, feet, clothing and jewelry away from the unit blades and all moving parts. Rotating and moving parts will cause serious injury if contacted during operation.
- DO NOT allow anyone to stank or lean on the unit during operation.
- ALWAYS Keep the safety stop switch system in adjustment and good operating condition at all times. Do not operate the trowel if it does not work properly. Out of control Trowels can cause serious personal injury and damage to fresh concrete surfaces. This system will automatically stop the unit if the operator loses control of it during operation.
- ALWAYS make sure the safety stop switch is disengaged (lever in the down position) before starting the unit. Keep one hand firmly on the handle while starting and do not let go of the handle during operation.
- ALWAYS wear protective clothing appropriate to the job site when operating the machine.
- ALWAYS close fuel valve on engines equipped with one when machine is not being operated.
- ALWAYS store the machine properly when it is not being used. The machine should be stored in a clean, dry location out of the reach of children.







1.2 Operator Safety while using Internal Combustion Engines

- DO NOT smoke when refueling the engine or during any other fuel handling operation.
- DO NOT refuel a hot or running engine.
- DO NOT refuel the engine near an open flame.
- DO NOT spill fuel when refueling the engine.
- If fuel is spilled during refueling, wipe it off from the engine immediately and discard the rag in a safe place. Do not operate the unit if fuel or oil leaks exist-repair immediately.
- NEVER operate this equipment in an explosive atmosphere.
- NEVER operate any gas powered equipment in a poorly ventilated or enclosed area.
- NEVER perform any work on the unit while it is running. Before working on it, stop the engine and disconnect the spark plug wire to prevent accidental starting.
- Avoid prolonged breathing of exhaust gases.
- Avoid contact with hot exhaust systems and engine parts.
- Allow engine to cool before performing any repairs or service.
- ALWAYS transport and handle fuel only when contained in approved safety containers.
- ALWAYS keep the area around the muffler free of debris such as leaves, paper, cartons, etc. A hot muffler could ignite the debris and start a fire.



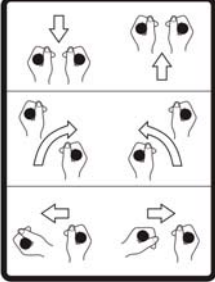



SAFETY INFORMATION

1.4 Safety and Operating Labels

Masalta machines use international pictorial labels where needed. These labels are described below:

Label	Meaning
	<p>DANGER! Engines emit carbon monoxide; operate only in well-ventilate area. Read the Operation Manual for machine information. No sparks, flames, or burning objects near the machine. Shut off the engine before refueling. Use only clean, filtered unleaded gasoline.</p>
	<p>WARNING! Cutting hazard. Always replace blade guard!</p>
	<p>Steering control. Refer to section Steering.</p>
	<p>WARNING! Always wear hearing and eye protection when operating this machine.</p>
	<p>Water tank fill. Use only clean water or water-based retardants.</p>
	<p>CAUTION! Check the fuel. Use only clean, filtered gasoline fuel.</p>

SAFETY INFORMATION

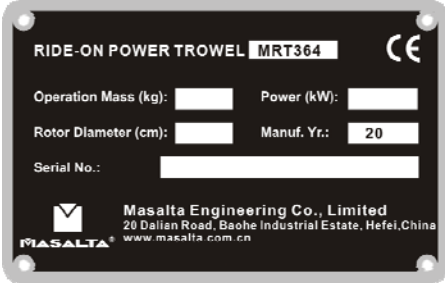
Label	Meaning
	<p>WARNING! Hand injury if caught in moving belt. Always replace belt guard.</p>
	<p>CAUTION! Tie-down point.</p>
	<p>Key switch, engine start: Off On Start</p>
	<p>WARNING! Hot surface!</p>
	<p>WARNING! Read and understand the supplied Operation Manual before operating the machine. Failure to do so increase the risk of injury to yourself or others.</p>
	<p>CAUTION! Read and understand the supplied Operator's Manual before operating the machine. Failure to do so increase the risk of injury to yourself or others.</p>
	<p>CAUTION! Lifting point.</p>
	<p>A nameplate listing the model number and serial number is attached to each unit. Please record the information found on this plate so it will be available if the nameplate lost or damaged. When requesting service information, the serial number should be specified of the unit.</p>

OPERATION

2.1 Controls

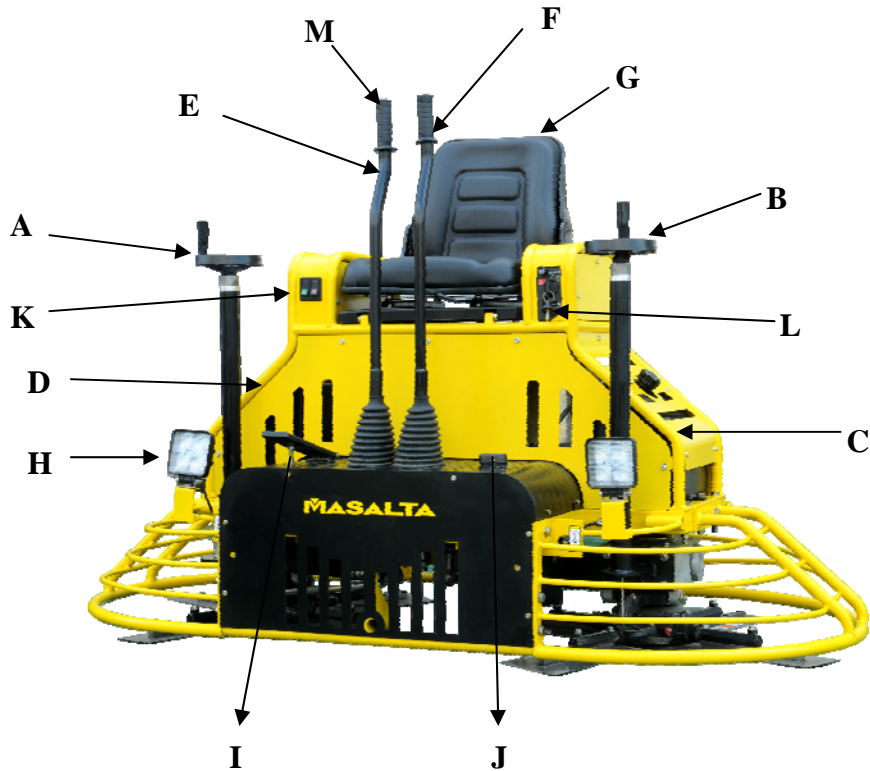

Ref.	Description	Ref.	Description
A	Right Pitch Control	H	Work Light (one each side)
B	Left Pitch Control	I	Right Foot Pedal (Safety Stop Switch)
C	Water Tank	J	Left Foot Pedal (Throttle Control)
D	Fuel Tank	K	Work Light Switch
E	Right Control Arm	L	Engine Keyswitch
F	Left Control Arm	M	Water Spray Control
G	Operator's Seat		

2.2 Operating Principle

The following instructions were compiled to provide you information on how to obtain long and trouble free use of the unit. Periodic maintenance of this unit is essential. Read the manual in its entirety and follow the instructions carefully. Failure to do so may injure yourself or a bystander.

OPERATION

2.3 Delivery Checks

Immediately on taking delivery of your new equipment and before putting it into service.

- Read the operation manual completely—it could save a great deal of unnecessary expense.
- Read the engine manual supplied.
- Check the general condition of the equipment –has it been damaged during delivery?
- Check engine oil level.
- Check fuel levels.

Recommended lubricants are detailed in the Care and Maintenance section.

2.4 Before Starting

New Ride-on Power Trowel has been assembled and tested at the factory. However, before starting the trowel, the following items should be checked:

- Fuel level
- Water level
- Water level
- Oil level in the engine
- Condition of the air filter
- Condition of trowel arms and blades
- Grease the trowel arms daily.

NOTICE: Check the oil level in the engine and gearbox. Engine and trowel warranties are VOID if this unit is run without oil.

2.5 To Start

Before starting the operator must know the location and function of all controls.

1. Adjust the chair to the comfortable position for the operator.
2. Push down on the left safety stop pedal, turn the engine keyswitch, and hold it until the engine starts.

NOTICE: If the engine is cold, pull out the choke control knob fully. The choke may need to be opened even when starting a warm engine.

NOTICE: Cranking the engine for more than 5 seconds can cause starter damage. If the engine fails to start, release the keyswitch and wait 10 seconds before operating the starter again.

3. Allow the engine to warm up before operating the trowel.
4. Push down on the throttle foot pedal to start the trowel

2.6 To Stop

1. Return the control levers to their neutral position and release pressure on the throttle foot pedal.
2. Release pressure on the safety stop switch.
3. To stop the engine, turn the keyswitch to “O” (off).

NOTICE: Release the safety stop switch for emergency stop.

OPERATION

2.7 Operation

To utilize your Ride-On Trowel to its fullest capacity, the machine should be driven in the direction that the operator is facing. This will finish the widest possible area, while giving the operator and excellent view of the slab surface about to be troweled. When the machine reaches the end of the slab, make a 180° U-turn, and repeat the straight line of direction to the other end of the slab.

NOTICE: DO NOT use excessive pressure on the control levers. Excessive pressure does not increase the reaction time of the machine and can damage the steering controls.

NOTICE: Attempting to use the trowel too early in the curing stage of the concrete may result in an undesirable finish. Only experienced concrete finishers should operate the trowel.

2.8 Steering

Refer to the illustration for the necessary hand motions to move the trowel in the desired direction, described below:

1. reverse
2. forward
3. rotate clockwise
4. rotate counter-clockwise
5. left sideways
6. right sideways

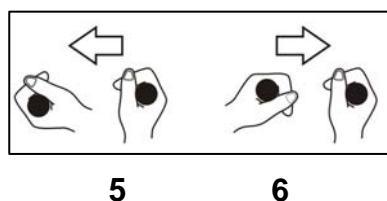
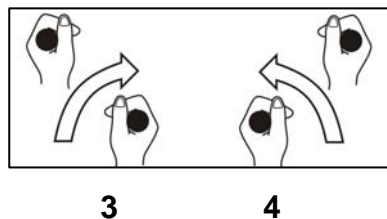
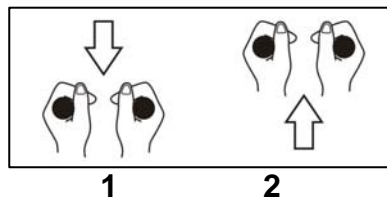

2.9 Pitch Adjustment

When changing or setting the pitch (angle) of the trowel blades, slow the machine, set the desired pitch on the left side of the machine, then adjust the right side to match.

To increase the pitch, turn the pitch control inward.

MAINTENANCE

3 MAINTENANCE

3.1 Periodic Maintenance Schedule

The chart below lists basic trowel and engine maintenance. Refer to engine manufacturer's Operation Manual for additional information on engine maintenance. A copy of the engine Operation Manual was supplied with the machine when it was shipped. To service the engine, tilt the seat forward.

	Daily	Every 20 hours	Every 50 hours	Every 100 hours	Every 200 hours	Every 300 hours
Grease trowel arms.	●					
Check fuel level.	●					
Check engine oil level.	●					
Inspect air filter. Replace as needed.	●					
Check external hardware.	●					
Pressure wash all surfaces until free of concrete.	●					
Check oil level in gearboxes.		●				
Grease gearbox, drive system and pitch posts fittings.		●				
Grease control linkage.		●				
Check drive belt for wear.			●			
Change engine oil.				●		
Check fuel filter.				●		
Clean and check spark plug.					●	
Replace oil filter.					●	
Replace spark plug.						●
Replace fuel filter.						●
Replace gearbox pressure relief valve.						●
Replace oil in gearboxes.						●

3.2 Trowel Gearbox

Check the gearboxes for the correct oil level after every 20 hours of operation. Change the gearbox oil every 300 hours.

NOTICE: DO NOT mix types of gear oil. DO NOT overfill the gearbox with oil. Damage to the gearbox may occur if oils are mixed, or if the gearbox is overfilled. See Technical Data for oil quantity and type.

MAINTENANCE

3.3 Lubrication

1. Engine oil

The long life and successful operation of any piece of machinery is dependent on frequent and thorough lubrication

Before using the trowel, always check your engine for oil. Use proper engine oil as recommended in the engine manufacturer's manual. Fill crankcase to levels as recommended.

2. Trowel

The drive system, gearbox and pitch posts are equipped with several grease fittings. Grease these fittings once a week, or every 20 hours, to prevent wear.

Use a general purpose grease and add one to two shots of grease at each fitting.

3.4 Transporting Trowels

ALWAYS turn the engine off and remove the key from the machine before moving or transporting machine.

To hoist the trowel:

1. Attach a sling or chains through the tie-down point (a) on each side of the guard ring.



NOTICE: Make sure lifting device has enough capacity to hold machine (see identification plate on machine for weight).

2. Put the lifting tube (b) into the tube on each side of the guard ring.

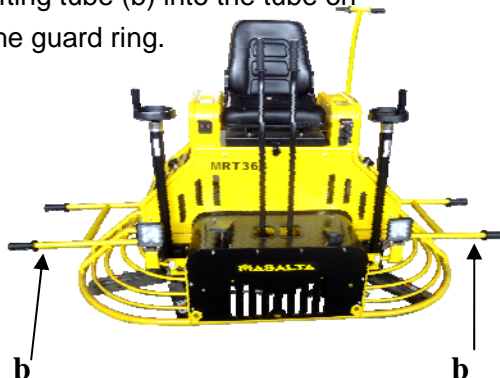

3.5 Spark Plug

Check and clean spark plugs regularly. A fouled, dirty spark plug may cause hard starting and poor engine performance. Set spark plug gap to recommended clearance. Refer to engine manual.



WARNING

The muffler and engine cylinder become very hot during operation and remain hot for a while after stopping the engine. Allow engine to cool before removing spark plug.

NOTICE: A loose spark plug can become very hot and may cause engine damage.

MAINTENANCE

3.6 Air Cleaner

Maintaining a clean engine will extend engine life. Keep air filter clean at all times. Clean air filter using the recommended solvent daily. See engine manual for proper cleaning procedure. Let the filter dry before reinstalling.



NEVER use gasoline or other types of low flash point solvents for cleaning the air cleaner. A fire or explosion could result.

WARNING

3.7 Troubleshooting

SYMPTOM	POSSIBLE CAUSES	SOLUTION
Engine does not start.	Engine problem.	Consult engine manufacturer's service manual.
Machine out of balance; wobbling excessively.	Operator is over-steering.	The movement of each gearbox is controlled by "stops" to provide the correct relationship of the control arm movement to machine movement. Excessive pressure on control arms in any direction will not increase reaction time and can damage steering controls causing machine to wobble.
	Trowel arm(s) bent.	Replace trowel arms(s).
	Trowel blade(s) bent.	Replace trowel blade(s).
	Main shaft(s) bent due to machine being dropped.	Replace main shaft(s).
Machine does not move.	Drive belt broken.	Replace drive belt.
	Vacuum between bottom of blades and surface of concrete.	Change pitch on blades to break suction.
	Key sheared in the main shaft.	Replace damaged key.
Trowel noisy.	Trowel blades have become misaligned and are contacting each other during rotation.	Replace damaged blades. Align blades so that one set represents a (+) and the other an (x) when viewed from above.
	Sheared key.	Check all keys in drive system.
	Loose clutch.	Tighten clutch.

TECHNICAL DATA

4. TECHNICAL DATA

Engine type		Honda GX690
Power	kw(hp)	18 (24)
Operating weight	kg(lb)	320 (705)
Blade speed	rpm	140
Blade pitch (range)	degree	0-30
Gearbox	type	Heavy duty
Gearbox lubrication	type	MOBIL 600XP320
	L(oz.)	0.78 (26) each
Working dia.	mm (in)	1890 (74)
Overlapping	type	Non-overlapping

Working Size (L x W x H): 1983x1006x1323mm (78 x 39 x 52 in)

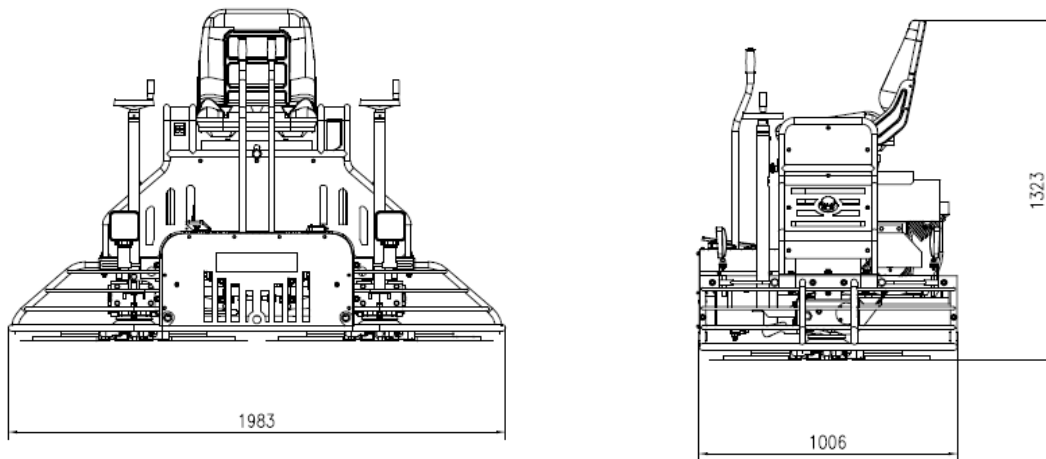

Sound Specification (According to 2000/14/EC)

Measured sound Power level	91.7dB(A)
Guaranteed sound power level	104.7dB(A)

Vibration Specification (According to ISO 2631 and EN 1033):

for **whole body**: 0.215m/s^2 for **hand arm**: 1.81m/s^2

The sound and vibration specifications were obtained with the unit operating on fully cured, water wetted concrete at nominal engine speed.

WARRANTY

MASALTA products are covered by warranty for a period of six (6) months from the date of purchase against defects in material or workmanship provided that:

- The product concerned has been operated and maintained in accordance with the operating instructions.
- Has not been damaged by accident, misuse or abuse.
- Has not been tampered with or repaired by any unauthorized person.

The owner is responsible for the cost of transportation to and from the authorized repairer and the unit is at the owners risk while in transit to and from the repairer.

Impact damage is not covered under warranty. Clutches are not covered under any warranty.

Engines are officially guaranteed by engine manufacturer. Please refer to the annex for engine warranty.

MAINTENANCE RECORD

PREVENTATIVE MAINTENANCE AND ROUTINE SERVICE PLAN

This Ride-on Power Trowel has been assembled with care and will provide years of service. Preventative maintenance and routine service are essential to the long life of your Ride-on Power Trowel. After reading through this manual thoroughly, you will find that you can do some of the regular maintenance yourself. However, when in need of parts or major service, be sure to see your dealer. For your convenience we have provided this space to record relevant data about your Ride-on Power Trowel.

Invoice Number:		Type of Machine:	
Date Purchased:		Dealer Name:	
Serial Number:		Dealer Phone:	

REPLACEMENT PARTS USED					MAINTENANCE LOG	
PART NO.	DESCRIPTION	QTY	COST	DATE	DATE	OPERATION

EC DECLARATION OF CONFORMITY
CE-KONFORMITÄTSERKLÄRUNG
DECLARACIÓN DE CONFORMIDAD DE LA CE
DÉCLARATION DE CONFORMITÉ C.E.

MASALTA ENGINEERING CO., LTD
Weisi Road, Baohe Industrial Estate, HeFei 230051, China

hereby certifies that the construction equipment specified hereunder / bescheinigt, da. das Baugerät / certifica que la máquina de construcción / atteste que le matériel :

1. Category / Art / Categoría / Catégorie:
Ride On Power Trowel

2. Type / Typ / Tipo / Type:
MRT364

has been produced in accordance with the following standards:/in übereinstimmung mit folgenden Richtlinien hergestellt worden ist:/ha sido fabricado en conformidad con las siguientes normas: / a été produit conformément aux dispositions des directives européennes ci-après :

2006/42/EC
2004/108/EC/EN55012:2007 (EMC)
EN12649



15.02.10

Date / Datum / Fecha / Date

Hermann Josef Lensing
Research and Development Manager



Distributed By

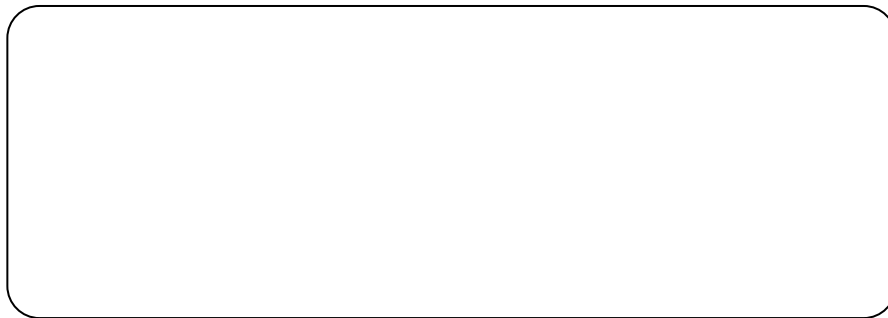

MASALTA ENGINEERING CO., LTD

Add: 20 Dalian Road, Baohe Industrial Estate, Hefei 230051, China

Tel: 86-551-64846601 Fax: 86-551-64846616

E-mail: sales@masalta.com.cn, masalta@mail.hf.ah.cn

[Http://www.masalta.com.cn](http://www.masalta.com.cn)