



Sales office and Warehouse:

Euro Shatal ApS
Murervej 5
DK-6710 Esbjerg V , DENMARK
Tel:(+45) 75168411
Fax: (+45)75168412
E-mail:euershatal@shatal.com
www.shatal.com

Euro Shatal Deutschland GmbH
Wernher von Braun Str.3
D-86368 Gersthofen ,GERMANY
Tel:(+49) 8214609580
Fax:(+49)8214609581
E-mail:info@euroshatal.biz
www.euroshatal.de

ST92



**OPERATING INSTRUCTIONS & SPARE PARTS LIST
POWER TROWELS**

**MANUAL & RESERVEDELSLISTE
GLITTEMASKINE**

**MANUAL & ERSATZTEILLISTE
FLÜGELGLITTER**

**MANUAL DE INSTRUCCIONES Y LISTA DE RECAMBIOS
FRATASADORA**



LIMITED WARRANTY

We warrant that this product is **free from defects in material or workmanship** under normal use and maintenance. Certain components, such as normal wear parts and engines are excluded from this warranty. We will, at our option, repair or replace any defective product or part covered by the Limited Warranty, free of charge at any authorized Servicing Dealer/Center using original replacement parts, subject to the limitations and exclusions described below.

Limited Warranty period: We will warrant the product to the original retail purchaser from the date of retail purchase for 12 month.

Battery: Lead Acid Batteries only: 180 days

This Limited Warranty does not cover:

- (a) Engines; a separate warranty provided with your product might apply.
Engines are warranted by the engine manufacture
- (b) Normal wear parts (parts and items that normally wear out with use), including without limitation spark plugs, bulbs, filters, lubricants, starter cords, belts, rubber parts, blades, and blade adapters are not covered, nor is damage due to normal wear, natural discoloration of materials, or dulling or damage to blades due to contact with abrasives, rocks, rods, or other foreign objects.
- (c) Damage related to abuse, misuse, neglect, modifications, alterations, use of unauthorized attachments, improper storage, or lack of lubrication or engine failure due to the use of oils that do not meet engine manufacturer's specifications, pressure cleaning or steam cleaning the product, excessive dirt, abrasives, salt water, moisture, corrosion, rust, or varnish.
- (d) Failure to perform required maintenance as described in the operator's manual will void this warranty.
- (e) Damage or failures due to improper set up, pre-delivery service or repair service by anyone other than an authorized servicing dealer during the warranty period.

To preserve your rights under this Limited Warranty, you must exercise reasonable care and use of the product, including following the preventive maintenance, storage, and fuel and oil usages as prescribed in the operator's manual.

In addition, you must cease using the product immediately upon any failure or damage, and take the product to an authorized servicing dealer prior to any further use.

WARRANTY EXCLUSIONS, DISCLAIMERS, AND LIMITED RIGHTS. WE WILL NOT BE LIABLE FOR ANY INCIDENTAL OR CONSEQUENTIAL DAMAGES. YOUR REMEDY IS LIMITED TO REPAIR OR REPLACEMENT OF THE PRODUCT OR PART, AT OUR DISCRETION. THERE ARE NO EXPRESS WARRANTIES OTHER THAN THOSE SET FORTH HEREIN. ANY WARRANTY IMPLIED BY STATE LAW (WHETHER OF MERCHANTABILITY OR FITNESS FOR A PARTICULAR USE OR OTHERWISE) IS HEREBY DISCLAIMED; WHERE SUCH A DISCLAIMER IS NOT PERMITTED BY LAW, THEN SUCH IMPLIED WARRANTY IS LIMITED FOR THE DURATION OF THE APPLICABLE LIMITED WARRANTY PERIOD. THIS LIMITED WARRANTY GIVES YOU SPECIFIC LEGAL RIGHTS, AND YOU MAY ALSO HAVE OTHER RIGHTS BASED ON YOUR LOCALITY.

How to obtain service. To obtain warranty service, you must take your product to an authorized Servicing Dealer/Center.

Any costs to transport or ship the product are your responsibility. You must present proof of purchase (including date, product model and serial number) to an authorized Servicing Dealer/Center for warranty service. Proof of purchase rests solely with you.

EURO SHATAL ApS

Head Office: Murervej 5, DK-6710 Esbjerg V, Denmark

Phone: (45) 75 168411 - Fax: (45) 75 168412 – E-Mail: euroshatal@shatal.com



GX models

GENERAL STORAGE INFORMATION

- If the engine has been running, allow it to cool for at least half an hour before cleaning. Clean all exterior surfaces, touch up any damaged paint, and coat other areas that may rust with a light film of oil.
- Select a well-ventilated storage area away from any appliance that operates with a flame, such as a furnace, water heater or clothes dryer.
- Avoid any area with a spark producing electric motor or where power tools are operated.
- If possible, avoid any area with high humidity. Humidity promotes rust and corrosion.
- Position the equipment so that the engine is level. Tilting the engine can cause fuel or oil leakage.
- If the engine is equipped with a battery, remove the battery and store it in a cool dry place. Recharge the battery once a month while the engine is in storage. This will help to extend the service life of the battery.

Draining the fuel tank and carburetor for seasonal or long term storage

You can either run your equipment until the fuel system (including the fuel tank) is completely empty or you can drain the fuel system as follows:

- Disconnect the fuel line to the engine, and drain the fuel tank into an approved gasoline container.
- If the fuel tank is equipped with a valve, turn the fuel valve to OPEN or ON position to enable draining.
- After draining is completed, reconnect the fuel line and turn the fuel valve to the OFF position.
- Loosen the carburetor drain screw, and drain the carburetor into an approved gasoline container. After draining is completed, tighten the carburetor drain screw.

EURO SHATAL ApS

Head Office: Murervej 5, DK-6710 Esbjerg V, Denmark

Phone: (45) 75 168411 - Fax: (45) 75 168412 – E-Mail: euroshatal@shatal.com



ENGLISH
CE DECLARATION OF CONFORMITY

We hereby declare that the equipment described below conforms to the relevant fundamental safety and health requirements of the appropriate CE Directives, both in its basic design and construction. This declaration will cease to be valid if any modifications are made to the machine without our expressed approval.

Product: Power Trowels Model : **ST92**

The said product has been sound tested per Directive 2000/14/EC

Conformity Assessment Procedure	Measured sound power level	Guaranteed sound power level
Annex VI	84 dB(A)	86 dB(A)

Relevant CE Machinery Safety Directives : **2006/42/EC, 2004/108/EC, pr EN 12649, 2000/14/EC**

Appropriate internal measures have been taken to ensure that series-production units conform at all times to the requirements of current CE Directives and relevant standards. The signatories are empowered to represent and act on behalf of the company's management.

DANSK
CE OVERENSTEMMELSEDEKLARATION

Vi erklærer hermed, at det nedenstående produkt er fremstillet i overensstemmelse med de tilhørende og fundamentale sikkerheds- og sundhedsbetingelser fra de behørlige CE direktiver, både i dets grundlæggende formgivning og konstruktion. Denne deklaration vil ophøre med være gyldig, hvis der bliver foretaget nogen som helst ændring på maskinen uden vores tydelige tilladelse.

Produkt: Glittermaskine Model : **ST92**

Dette produkt er blevet støjtestet jf. direktiv 2000/14/EC

I overensstemmelse med vurderingsprocedure	Målt lydstyrkeniveau	Garanteret lydstyrkeniveau
Annex VI	84 dB(A)	86 dB(A)

Relevant CE maskinsikkerhedsdirektiv : **2006/42/EC, 2004/108/EC, pr EN 12649, 2000/14/EC**

Der er foretaget interne forholdsregler for at sikre, at produkter, der er fremstillet i serieproduktion, altid efterlever foreskrifterne fra gældende CE direktiver og relevante standarder. Underskriverne har tilladelse til at representere og handle på vegne af firmaets ledelse.

DEUTSCH
CE BESTÄTIGUNG VON DEKLARATION

Wir erklären, dass das beschriebene Produkt sich an die relevante, fundamentale Sicher- und Gesundheits-behörden in die passende CE Direktiven richten, auch in seinem grundsätzlichen Design und Konstruktion. Diese Deklaration verliert seine Gültigkeit, falls irgend eine Modifikation auf der Maschine ohne unsere Zulassung gemacht wird.

Produkt: Flügelglitter - Modell : **ST92**

Das genannte Produkt ist von der Direktiv 2000/14/EC getestet worden

Gemäss Prozedure	Gemessen Lautstärke	Garantierte Lautstärke
Annex VI	84 dB(A)	86 dB(A)

Relevante CE Maschinesicherheitsdirektiven : **2006/42/EC, 2004/108/EC, pr EN 12649, 2000/14/EC**

Wir haben interne Vorsichtsmassnahmen genommen, die Einheiten der Serienproduktion immer laut die Verlangen der laufenden CE Direktiven zu sichen und die relevanten Standarden zu erfüllen.

Die Signaturen sind in Auftrag der Management der Firma representiert.

ESPAÑOL
DECLARACION DE CONFORMIDAD CE

Nosotros declaramos que el producto descrito a continuacion cumple con los requerimientos fundamentales de seguridad y salubridad relevantes de las Directivas CE correspondientes, tanto en su diseño basico como en su produccion. Esta declaracion sera anulada si se efectua cualquier cambio en la maquina sin nuestro expreso consentimiento.

Producto: fratasadora modelos : **ST92**

El producto ha sido controlado de acuerdo a la Directiva 2000/14/EC

Procedimiento de conformidad	Nivel de potencia de sonido medida	Nivel de potencia de sonido garantida
Annex VI	84 dB(A)	86 dB(A)

Directiva Relevante: CE Machinery Safety Directives : **2006/42/EC, 2004/108/EC, pr EN 12649, 2000/14/EC**

Fueron tomados los recaudos necesarios para asegurar que las unidades producidas en serie cumplan en todo momento con las Directivas CE vigentes y los standares relevantes. Los signatarios estan autorizados para representar y actuar en nombre de la Direccion de la Compania.

Murervej 5
DK-6710 Esbjerg V , Denmark
Tel:(+45) 75168411
Fax: (+45)75168412
E-mail:euroshatal@shatal.com

Josef Levy
GENERAL MANAGER



Esbjerg V, March 2021

ENGLISH

- Laws governing safety aspects on machinery may vary between countries but the following guides will be useful to all operators:
- Before starting, carefully read the machine maintenance and operating manual and follow all the instructions.
- Use unleaded fuel only, for gasoline engines.
- Never operate the machine without the belt guard.
- Keep hand and feet away from moving parts while the machine is running.
- Do not operate the machine in closed places and inflammable environment.
- Operating the machine is advisable only with good lighting conditions.
- Hearing protection must be worn.
- Foot protection must be worn.
- Do not touch hot surfaces.

DANSK

- Sikkerhedslovgivningen på maskiner kan være forskellige landene imellem, men de følgende retningslinier er nyttige for alle operatører.
- Før start, venligst læs maskinens service og brugsanvisning, følg alle instruktioner nøje.
- Brug kun blyfri bensin, til alle bensin motorer.
- Brug aldrig maskinen uden remskive beskyttelse.
- Hænder og fødder skal holdes væk fra alle bevæglige dele når maskinen kører.
- Brug ikke maskinen i lukkede rum, eller ved brandfarlige områder.
- Anvend maskinen kun når der er god belysning.
- Hørevern er altid påbudt.
- Sikkerhedssko er altid påbudt.
- Rør aldrig ved varme flader.

DEUTSCH

- Die Sicherheitsgesetze für Maschinen können verschieden sein, aber die folgende anleitungen sind für alle operatoren verbindlich.
- Vor Arbeitsbeginn bitte Bedienungs – und Wartungsanleitung sorgfältig lesen und allen Empfehlungen folgen.
- Bitte nur bleifreies Benzin benutzen, bei allen Benzinmotoren.
- Bitte die Maschine nie ohne Keilriemengehäuse benutzen.
- Bitte Hände und Füße entfernt halten von allen beweglichen Teilen während die Maschine läuft.
- Bitte die Maschine nicht in feuergefährlichen oder geschlossenen Räumen benutzen.
- Bitte nur die Maschine benutzen wenn eine gute Beleuchtung vorhanden ist.
- Gehörschutz muss immer getragen werden.
- Sicherheitsschuhe müssen immer getragen werden.
- Heisse Flächen bitte nicht berühren.

DUTCH

- Wetgeving inzake veiligheidsaspecten van machines kunnen verschillen naargelang het land. Volgende gids kan door iedere gebruiker gebruikt worden.
- Voor het starten zorgvuldig de instructiehandleiding doorlezen, alle instructies moeten gevolgd worden.
- Alleen loodvrije benzine gebruiken, bij benzinemotoren.
- Nooit de machine gebruiken zonder V-snaarbescherming.
- Houd altijd handen en voeten weg van bewegende delen terwijl de machine loopt.
- Gebruik de machine niet in gesloten en brandgevaarlijke ruimtes.
- Gebruik alleen de machine bij goede verlichting.
- Gehoorbescherming moet altijd gedragen worden.
- Veiligheidsschoenen moeten altijd gedragen worden.
- Nooit warme vlakken aanraken.

ESPAÑOL

- Las leyes referentes a seguridad en el trabajo pueden cambiar de país en país. Las siguientes directivas son de provecho para todos los usuarios:
- Antes de usar la máquina por primera vez, lea cuidadosamente el Manual de Instrucciones y siga todas las instrucciones, precauciones y advertencias.
- En los motores a gasolina use solo gasolina sin plomo..
- Nunca opere la máquina sin la guarda de poleas o la guarda de disco de corte.
- Mantenga manos y pies alejados de partes móviles mientras la máquina está en funcionamiento.
- No utilice la máquina en espacios cerrados o en ambientes inflamables.
- Se recomienda utilizar la máquina solamente con buena iluminación.
- Utilice protección para los oídos.
- Utilice calzado de seguridad para trabajar con la máquina.
- No toque superficies calientes de la máquina.

OPERATION – MODEL ST62; 92; 122

STARTING – HONDA GX-160; GX-240

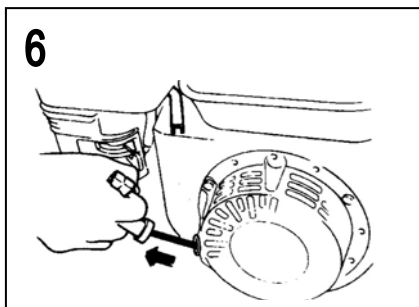
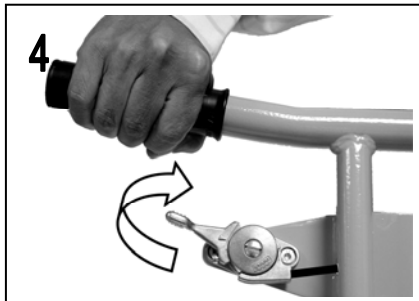
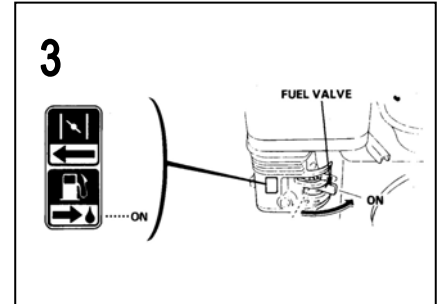
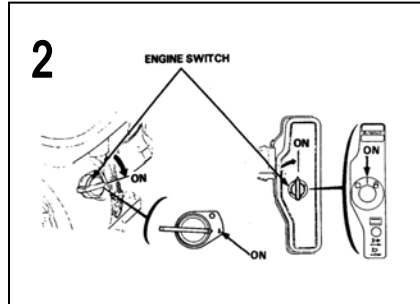
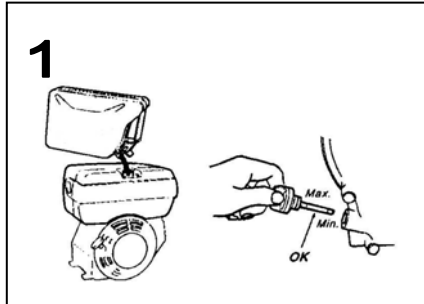

STOPPING

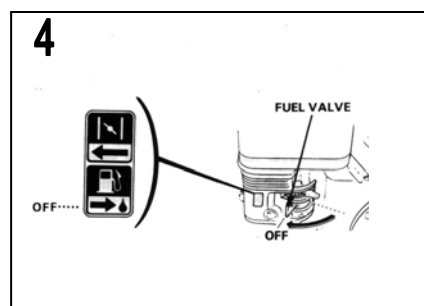
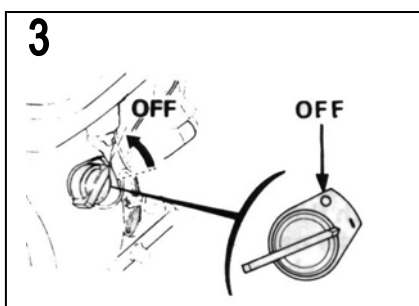

TECHNICAL SPECIFICATIONS
ENGLISH

MODELS	ST92 HONDA GASOLINE M12700.A	ST92 HONDA GASOLINE M12700.K
Cat. No.		
WEIGHT		
Net Weight	kg. 87	117
OPERATION DATA		
Max. Operating speed (At Engine speed 3600 rpm)	rpm 145	145
No.Of blades	4	4
DRIVE MOTOR		
Model	Honda GX160 Recoil start	Honda GX240 Recoil start
Output	HP 5.5	8
Engine speed	rpm 3600	3600
Fuel tank	litres 3.6	6
Engine oil SAE 15W/40	litres 0.6	1.1
NOISE AND VIBRATIONS		
Sound power level according to BS 5969 type 2 & IEC 651 (*)		
Low idle LwA=dB(A)	84	87
Vibration values a=m/s ²	The hand – arm vibration values according to ISO 5349	
	1.9	1.8

(*) The above noise level and vibration values were determined at normal speed of the engine. During operation these values may differ because of the actual operational conditions.

TEKNISKE SPECIFIKATIONER
DANSK

MODEL	ST92 HONDA BENZIN M12700.A	ST92 HONDA BENZIN M12700.K
Kat. Nr.		
VÆGT		
Nettovægt	kg. 87	117
BRUGSINFORMATION		
Max. omdrejninger i min. o.m. (v. motoren omdrejn. 3600o.m.)	145	145
Antal blade	4	4
HØVEDMOTOR		
Model	Honda GX160 Rekylstart	Honda GX240 Rekylstart
Ydelse - HK	5.5	8
Motoromdrejningshastighed - o/m	3600	3600
Brændstoftank - liter	3.6	6
Motorolie - liter SAE 15W/40	0.6	1.1
STØJ OG VIBRATIONER		
Lydstyrke if. BS 5969 type 2 & IEC 651 (*)		
Tomgang LwA=dB(A)	84	87
Vibrationsværdier A=m/s ²	Hånd – arm vibrationsværdier if. ISO 5349	
	1.9	1.8

(*) De ovennævnte støjniveau- og vibrationsværdier er bestemt ud fra normale omdrejninger på motoren. Disse værdier kan variere under kørslen pga. de aktuelle arbejdsforhold.

TECHNISCHE DATEN
DEUTSCH

MODELL	ST92 HONDA BENZIN M12700.A	ST92 HONDA BENZIN M12700.K
Kat. Nr.		
GEWICHT		
Nettogewicht	kg. 87	117
KOMPRESSIONS DATEN		
Max. Umdrehungen (Bei Motorumdreh. 3600 upm)	upm 145	145
Anzahl Blätter	4	4
MOTOR		
Modell	Honda GX160 Rückstoss start	Honda GX240 Rückstoss start
Leistung	PS 5.5	8
Motorumdrehungen	u/m 3600	3600
Brennstofftank	liter 3.6	6
Motoröl SAE 15W/40	liter 0.6	1.1
GERÄUSCH UND VIBRATIONEN		
Geräuschniveau laut BS 5969 Type 2 & IEC 651 (*)		
Lehrlauf LwA=dB(A)	84	87
Vibrationswert a=m/s ²	Der Handgriff – Armvibrationswert gemäß ISO 5349	
	1.9	1.8

(*) Die erwähnten Geräusch- und Vibrationswerten sind bei normaler Lautstärke bestimmt. Während die Operation dieser Werten können verschieden sein auf Grund der aktuellen, operationellen Arbeitzustandes.

ESPECIFICACIONES TECNICAS
ESPAÑOL

MODELOS	ST92 HONDA GASOLINA M12700.A	ST92 HONDA GASOLINA M12700.K
Nr. Catalogo.		
PESO		
Peso Neto	kg. 87	117
DATOS DE OPERACION		
Velocidad Max.de Operacion (Motor a 3600 r.p.m.) rpm	145	145
Numero de Palas	4	4
MOTOR		
Modelo	Honda GX160 Arranque manual	Honda GX240 Arranque manual
Potencia HP	5.5	8
Rotaciones de Motor	rpm 3600	3600
Tanque de Combustible	litros 3.6	6
Aceite de motor SAE 15W/40	litros 0.6	1.1
EMISION SONORA Y VIBRACION		
Nivel de Emision Sonora de acuerdo a BS 5969 type 2 & IEC 651 (*)		
Baja en Vacio LwA=dB (A)	84	87
Valores de vibracion a=m/s ²	Valores de Vibracion mano - brazo segun la Directiva EN ISO 5349	
	1.9	1.8

(*) Los niveles de emision sonora y vibracion han sido establecidos con el motor girando al numero de revoluciones normal. Durante el uso esto valores pueden ser diferentes de acuerdo a las condiciones en las que opere la maquina.

DIMENSIONS – MÅL – MASSEN - DIMENSIONES

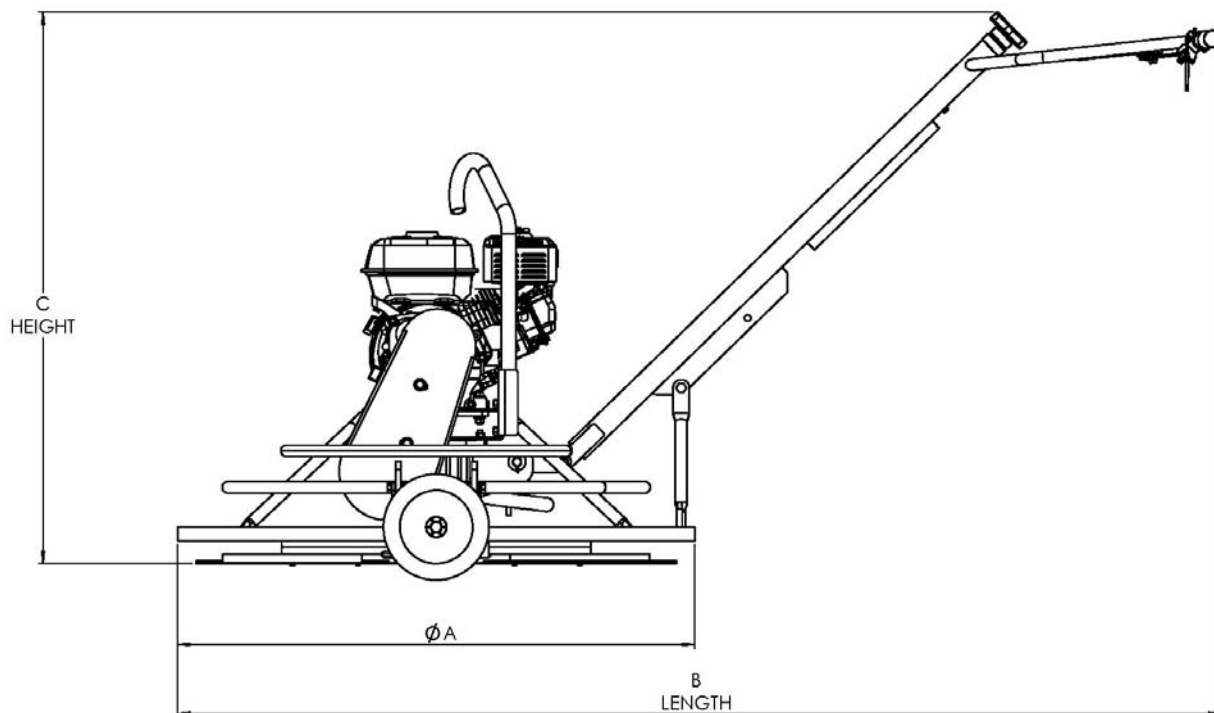

MODEL MODEL MODELL MODELO	ØA	B Length Længde Länge Largo	C Height Højde Höhe Alto	Net Weight Nettovægt Nettogewicht Peso Neto			
				Kg			
	mm	mm	mm	ROBIN EX-17	ROBIN EX-27	HONDA GX-160	HONDA GX-240
ST92	950	1915	1010	87	-	87	99



ENGLISH

TRANSPORT TO WORK SITE :

- To avoid burns or fire hazards, let engine cool before transporting machine or storing indoors.
- Turn fuel valve to the off position and keep the engine level to prevent fuel from spilling.
- Tie the machine to the vehicle to prevent sliding or tipping over.

INSTRUCTION FOR LIFTING MACHINE: SEE PICTURES 9 PAGE 9

- Never walk or stand under a machine being lifted.
- Use only the frame lifting hook for lifting the machine.
- Use only tested and authorised lifting equipment.

OPERATION:

ENGINE CHECK BEFORE STARTING

1. Fill fuel tank.
2. Check oil level in engine crankcase and top up necessary type of oil according to manufacturer's instructions.
3. Lift the wheels. (See Picture 1 Page 9)
4. Move the handle (Round black knob) on the safety switch to the forward position. (See Picture 4 Page 9)

STARTING THE ENGINE - SEE PICTURES 1-5 PAGE 9 – HONDA GX-160/GX-240

OPERATING THE MACHINE

Assembly of the float disc - (See Picture 10 Page 9)

1. Place the trowel on to the float disc.
2. Rotate the blades so that the blades move underneath the 4 L shaped brackets.
3. Rotate the blade adjustment knob so that the blades rise.
4. Ensure that there is sufficient pressure on the blades and that the disc is tightly attached to the trowel.

NOTE

The trowel is to be used only by experienced operators. They must have the knowledge of when the concrete is ready to be troweled, the angle of the blades and the operating speed. These instructions should be used as general guidance only.

Floating concrete

Use the float disc or the blades set at a small angle for floating.

The concrete should be sufficiently set before the floating operation takes place. This must be determined by the operator.

Floating is done at a low speed. To have the machine move to the right bear down slightly on the handle. Lift gently on the handle to have machine move to the left. Do not operate machine in one spot but keep it moving over the surface for either floating or finishing of concrete. If machine is allowed to stand in one spot while not operating, lift up on the handle to break loose the suction on the trowels and move to a new spot before starting to operate the machine.

Finishing concrete

The finishing operation is carried out with the blades set at a large angle and at a high speed.

STOPPING THE ENGINE OPERATOR POSITION - SEE PICTURES 6-8 PAGE 9 – HONDA GX-160/GX-240

DANSK

TRANSPORT :

- For at undgå ild og ildspåsættelse, lad motoren køle af før den transporteres og lagres indendørs
- Luk benzindækslet og hold motoren vandret for at undgå benzinudslip
- Bind maskinen fast på køretøjet for at undgå, at den skal falde af eller vælte under transporten

ANVISNINGER FOR LØFTNING AF MASKINEN : SE BILLEDER 9, SIDE 9

- Gå eller stå aldrig under maskinen når den er løftet
- Benyt kun rammeløftegrebet for løftning af maskinen
- Benyt kun godkendte og sikre løftemekanismer.

DRIFT:

MOTORCHECK FØR START

1. Fyld brændstof på tanken
2. Check olieniveau i krumtamphuset og fyld op om nødvendigt med den type olie, motorproducenten foreskriver
3. Løft hjulene. (See Foto 1 Page 9)
4. Flyt håndtaget (rund sort knap) på sikkerhedsafbryderen til fremadrettet position. (See Foto 4 Page 9)

MOTOREN STARTES - SE BILLEDERNE 1-5, SIDE 9 – HONDA GX-160/GX-240

BETJENING AF MASKINEN.

Montering af glitteskive - (See Foto 10 Page 9)

1. Placer glittemaskinen ovenpå glitteskiven.
2. Roter glittebladene så at bladene neden-under får fat i de 4 påsvejste beslag på glitteskiven.
3. Roter bladernes tilpasningsknap så at bladene får fat.
4. Sørg for at der er nok pres på bladene og glitteskiven er fastgjort godt til glitte-maskinen.

Behandling af betonen

Anvend glitteskiven eller bladsættet til et mindre område, der skal glittes.

Betonen skal være tilpas behandlet, før man påbegynder glitningen. Dette skal afgøres af brugeren.

Glitning skal gøres ved lav hastighed. Ved at trykke lidt ned på håndtaget, får du maskinen til at gå lidt til højre. Slip lidt på håndtaget og maskinen går lidt til venstre. Maskinen skal køres jævnt over overfladen. Den må ikke køre på samme sted hele tiden for at glitte jævnt eller sørge for en passende finish af betonen. Når du er færdig det ene sted, løft op i håndtaget for at afbryde arbejdet dér og flyt den til det nye arbejdssted, før arbejdet fortsætter.

Afslutning af glitningen

Det afsluttende arbejde gøres med bladsættet med den størst mulige vinkel på og ved høj hastighed.

HVORDAN MOTOREN STOPPES, BETJENINGSPOSITION - SE BILLEDERNE 6-8, SIDE 9 – HONDA GX-160/GX-240



DEUTSCH

TRANSPORT ZUR ARBEITSSTELLE :

- Um Brennen oder Feuerfalle zu verhindern, lassen Sie den Motor abkuehlen bevor dessen Transportierung oder Lagerung im Haus.
- Schliessen Sie die Benzinklappe und halten Sie den Motor waagrecht um Benzinverlust zu verhindern.
- Binden Sie die Maschine auf dem Fahrzeug fest um Gleiten oder Umkippen zu verhindern.

ANWEISUNGEN ZUM HEBEN DER MASCHINE : SIEHE FOTO 9 SEITE 9

- Gehen oder stehen Sie nie unter einer Maschine die gehoben wird.
- Benutzen Sie nur den Rahmenhebegriff zum Heben der Maschine.
- Benutzen Sie nur geprüfte und glaubwürdige Hebegeeraete. Vor dem Heben pruefen Sie ob die Gummipuffer und der Schutzrahmen korrekt befestigt und unbeschadigt sind.

BETRIEB :

MOTOR KONTROLLIEREN BEVOR START

1. Der Benzintank füllen
2. Der Ölstand im Motorcrankbox kontrollieren und auffüllen wenn notwendig laut der Manual des Produzentens
3. Die Räder hochheben. (See Foto 1 Seite 9)
4. Bewegen Sie den Griff (runder schwarzer Knopf) am Sicherheitsschalter in die vordere Position. (See Foto 4 Seite 9)

DER MOTOR STARTEN - SIEHE FOTO 1-5, SEITE 9 – HONDA GX-160/GX-240

DER MASCHINE IM GEBRAUCH

Montierung der Glätteplatte - (See Foto 10 Seite 9)

1. Der Flügelglitter auf der Glätteplatte stellen.
2. Die Flügel drehen so dass the Flügel unter die 4 angeschweiste Beschläge kommen.
3. Rotiere der Blattjustierknopf wobei die Blätter aufsteigen.
4. Bitte sichern dass genug Druck an die Blätter sind und dass die Platten straff an der Flügelglitter gemacht sind.

Glatten der Beton

Der Glätteplatte oder der Blattsatz wenn einer kleine Ecke geglättet werden soll. Der Beton soll genug trocken sein bevor Sie mit Glatten der Beton anfangen. Der Gebräucher muss dies selbst entscheiden. Der Glatten soll bei langsamer Geschwindigkeit geschien. Wenn Sie die Maschine nach rechts drehen möchten, langsam der Handgriff unterdrücken. Vorsichtig in der Handgriff lüften wenn Sie nach links drehen möchten. Nicht die Maschine an die gleiche Stelle stehen lassen sondern lass sie über die Oberfläche in Bewegung für entweder Glatten oder Vollendung der Beton stellen. Falls die Maschine ohne Glatten an die gleiche Stelle stehen soll, lüften Sie mit der Handgriff für eine Lösung der Saugen an die Blätter und an eine neue Stelle stellen, bevor Sie wieder der Maschine aufstarten.

Der Beton fertig machen

Der Abschlussung der Beton ist bei die Blätter schräg und bei hohe Geschwindigkeit fertiggestellt.

ANHALTEN DER MOTOR BEDIENER POSITION - SIEHE FOTO 6-8, SEITE 9 – HONDA GX-160/GX-240

ESPAÑOL

INSTRUCCIONES PARA EL TRANSPORTE DE LA MAQUINA :

- Para evitar quemaduras o peligro de fuego, deje enfriar el motor antes de transportar o almacenar la maquina.
- Coloque la valvula de combustible en posicion OFF y mantenga la maquina nivelada para evitar que se derrame
- Amarre la maquina al vehiculo para evitar el deslizamiento o la caída de la maquina

INSTRUCCIONES PARA ELEVAR LA MAQUINA: VER FOTOS 9 PAGINA 9

- Nunca camine o se pare debajo de una maquina que esta siendo levantada.
- Utilice solamente el lugar de enganche para elevar la maquina.
- Utilice solamente equipo probado y autorizado para elevar la maquina. Antes de elevar la maquina controle que los topes de goma y la caja estan correctamente ajustados y no dañados

OPERACION :

ANTES DE ARRANCAR

1. Llene el tanque de combustible.
2. Controle el nivel de aceite en el carter del motor y agregue si es necesario. Utilice siempre el aceite recomendado por el fabricante del motor.
3. Levantar las ruedas (Ver Figura 1 Pagina 9)
4. Mueva la manija (perilla negra redonda) en el interruptor de seguridad a la posición delantera. (Ver Figura 4 Pagina 9)

ENCENDIDO DEL MOTOR - VER FIGURA 1-5 PAGINA 9 – HONDA GX-160/GX-240

OPERADO DE LA MAQUINA

Ensamblado del Disco de Alisado - (Ver Figura 10 Pagina 9)

1. Colocar la fratasadora sobre el disco de alisado.
2. Girar las palas para que estas queden debajo de los 4 soportes en forma de "L".
3. Girar la perilla de ajuste de las palas asi las palas se levantan.
4. Asegurarse que has suficiente presion en las palas para que el disco quede firmemente amarrado a al fratasadora.

NOTA

La fratasadora debe ser usada solo por operadores experimentados. Ellos deben tener conocimiento de cuando el cemento esta en condiciones para ser fratasado, el angulop de las palas y la velocidad de giro. Estas instrucciones deben ser usadas como una guia general solamente.

Fratasado de Cemento

Use el disco de alisado o las palas a un pequeño angulo para fratar. El cemento debe haber reposado suficiente antes de efectuar el fratasado. Esto debe ser determinado por el operario. El fratasado se hace a baja velocidad. Para hacer que la maquina se mueva a la derecha aprete un poco el manilla. Levante levemente el manillar para que la maquina se mueva hacia la izquierda. No deje la maquina andando en un punto fijo, hay que mantenerla en movimiento sobre la superficie tanto para el fratasado como para el acabado del cemento. Si la maquina se deja en un punto sin funcionar sobre el cemento, levante el manillar para soltar la succion en las palas y muevala a otro punto antes de ponerla en funcionamiento.

Acabado del Cemento

La operacion de acabado se realiza con la palas a un angulo mayor y a alta velocidad.

DETENCION DEL MOTOR Y POSICION DEL OPERADOR - VER FIGURA 6-8 PAGINA 9 – HONDA GX-160/GX-240



ENGLISH

IMPORTANT ADVICE :

The manufacturer declines all responsibility for loss or damage resulting from misuse or any modification or alteration that does not conform to the manufacturer's original specifications.

At the workstation, the sound pressure level may exceed 97 db (A). In this case individual protection measures must be taken

SPARE PARTS ORDERING :

When ordering spare parts, please mention machine serial no., part no. and description.

SCRAPPING :

In the event of deterioration and scrapping of the machine, the following items must be disposed of in accordance with the requirements of the legislation in force.

Main Materials:

1. Engine : Aluminium (AL), Steel (AC), Copper (CU), Polyamide (PA)
2. Machine : Steel sheet (AC)

The instructions for use and spare parts found in this document are for information only and are not binding. As part of our product quality improvement policy, we reserve the right to make any and all technical modifications without prior notice.

MAINTENANCE SCHEDULE :

Check all external screw connections for tight fit approx. 8 hours after first operation.		
Parts	Maintenance	Maintenance interval
Air filter	Check for external damage and tight fit. Check foam and filter insert clean or replace if necessary.	daily
Engine oil Other parts	Check oil level, top up if necessary. Remove all dirt, stones etc. from the Power trowel after each day of operation..	
Belts	Check tension and wear – replace if necessary.	weekly
Engine	See engine manufacturers handbook	

MAINTENANCE :

Monthly maintenance:

- Perform maintenance work on engine according manufacturer's instructions.
- Check belt tightness and tighten if necessary.
Belts should be move 10 –15 mm when pushed by the thumb (See picture 11 page 9).
- Check and retighten bolts and nuts.
- Apply grease to the 4 grease nipples on the spider block.

DANSK

VIGTIGE RÅD :

Producenten fraskriver sig ethvert ansvar for tab eller skader som resultatet af misbrug eller ændringer af produkterne, som ikke er i overensstemmelse med producentens originale specifikationer.

Lydstyrken kan på arbejdspladsen overstige 97 db (A). I så fald må man tage individuelle beskyttelsesforanstaltninger

RESERVEDELSBESTILLING :

Når man bestiller reservedele, meddel da maskinserienummer, delnummer og en beskrivelse

SKROTNING :

Når tiden rinder ud for maskinen, og den dermed skal skrotes, skal man i den forbindelse tage hensyn til genanvendelse iht. gældende lovkrav.

Hovedmaterialer:

1. Motor : Aluminium (AL), stål (AC), kobber (CU), polyamid (PA)
2. Maskine : Stålblade (AC)

Manualen for anvendelsen og reservedele i denne sektion er kun vejledende og er ikke bindende. Som er del af vores politik mhp. produktkvalitetsforbedringer, kan vi uden forudgående varsel foretage enkelte eller hele tekniske ændringer.

VEDLIGHOLDELSPLAN :

Check alle udvendige skruer efter ca. 8 driftstimer og spænd dem om nødvendigt efter		
Dele	Vedligehold	Vedholdelsesinterval
Luffilter	Check for udvendige skader og udbedre dem evt. Check skumgummi og filter, isæt rent eller erstat om nødvendigt.	Daglig
Motorolie	Check olieniveau, fyld op om nødvendigt (motor skal stå lige)	
Andre dele	Al snavs, fastkørte sten osv .skal fjernes fra glitemaskine efter endt arbejdsdag	
Remme	Check dem for slid og stramhed – erstat om nødvendigt	Ugentlig
Motor	Se motorhåndbogen fra producenten	

VEDLIGHOLDDELSE :

Månedlig vedligeholdelse :

- Foretag vedligeholdelsesarbejde på motoren efter producentens manual
- Check remmens stramhed og stram den om nødvendigt
Remmen bør kunne bevæge sig 10 –15 mm, hvis den trykkes ned med tommeltotten (se billede 11, side 9).
- Check og spænd bolte og møtrikker efter
- Anvend fedt til 4 smørenippler på spider blok.



DEUTSCH

WICHTIGE RATSCHLÄGE :

Der Hersteller übernimmt keine Verantwortung für Schäden, die durch Missbrauch oder falsche Handhabung, Änderungen oder Missachtung die Angaben der Hersteller entstanden sind.

An der Baustelle, kann der Geräuschpegel 97 db (A) überschreiten. In diesem Fall müssen individuelle Hörschutzmassnahmen getroffen werden.

BESTELLUNG VON ERSATZTEILE :

Wenn Sie Ersatzteile bestellen, geben Sie uns Seriennummer, Artikelnummer und eine Beschreibung an.

VERSCHRÖTTUNG :

Zum umweltgerechten Entsorgung der Maschine müssen die nachstehende Teile entsprechend der gesetzlichen Vorschriften behandelt werden.

Hauptsächlich verwendetes Material:

1. Motor : Aluminium (AL), Stahl (AC), Kupfer (CU), Polyamide (PA)
2. Maschine : Stahlplatte (AC)

Der Manual und die Ersatzteile in diesem Dokument sind richtungsweisend und nicht verbindlich. Entsprechend unsere Politik, immer der Qualität unsere Produkt zu verbessern, sind alle technischer Änderungen ohne weitere Informationen vorbehalten.

WARTUNGSINTERVALLEN :

Alle externe Schrauben nach die ersten ca. 8 Betriebsstunden nachschrauben		
Teile	Wartung	Wartungsintervall
Luftfilter	Für externe Schäden untersuchen und reparieren Schaum und Filter untersuchen, neu reinigen oder ersetzen wenn notwendig	Täglich
Motoröl Andere Teile	Ölstand kontrollieren, auffüllen wenn notwendig Jeglichen Schmutz, Steine usw. von der flügelglitter entfernen nach jedem Arbeitstag.	
Reimen	Schnalle und Verschleiß kontrollieren – ersetzen wenn notwendig	Wochenlich
Motor	Siehe der Manual des Motorherstellers	

WARTUNG :

Monatliche Wartung :

- Wartung am Motor laut der Manual der Hersteller ausführen
- Die Fästung der Reime kontrollieren und fästigen wenn notwendig
Die Reimen sollen 10 –15 mm Bewegung haben, wenn Sie mit dem Daumen schieben (Siehe Foto 11, Seite 9)
- Die Bolzen und die Mutter kontrollieren und fästigen
- Fett für die 4 Fettnippel auf der Motorblock.

ESPAÑOL

ANUNCIO IMPORTANTE :

El productor declina toda responsabilidad por perdidas o daños resultantes de mal uso o cualquier modificacion o alteracion respecto de las especificaciones originales del productor.

En el lugar de trabajo, el nivel de presion acustica puede exeder los 97 db (A). En este caso es obligatorio tomar medidas de proteccion.

ORDEN DE REPUESTOS :

Al ordenar repuestos, por favor indique el numero de serie de la maquina, el numero de parte y la descripcion.

DESECHO :

En el caso de deterioro y puesta de la maquina a desecho, las siguientes partes deben desecharse de acuerdo con los requerimientos de la legislacion en vigencia.

Materiales Principales:

1. Motor: Aluminio (AL), Acero (AC), Cobre (CU), Poliamida (PA)
2. Maquina: Hojas de Acero (AC)

Las instrucciones para el uso y repuestos en este documento son solo informativas y no restrictivas. Como parte de la política de mejoramiento continuo de productos el fabricante se reserva el derecho de introducir cualquier y todo cambio tecnico sin previo aviso.

PROGRAMA DE MANTENIMIENTO :

Ajustar todas as tuercasy tornilds exteriores despoes de las primelas 8 ls deuso.		
Partes	Mantenimiento	Intervlo de mantenimiento
Filtro de Aire	Controlar que no haya daño enerno y controlar ajuste. Controlar que la esponja y el injerto esten limpios. Reemplazar si fuere nesesarario.	diario
Aceite de motor	Controlar el nivel de aceite. Agregar hasta max. si fuere nesesarario.	
Otras partes	Quitar tierra, piedras, etc de la fratasadora al final del trabajo diario	
Polea	Controlar tension desgaste – reemplazar si fuere necesario.	semanal
Motor	Leer el manual del fabricante y seguir sus indicaciones	

MANTENIMIENTO :

Mantenimiento mensual:

- Realice el trabajo de mantenimiento de acuerdo a las instrucciones del fabricante.
- Controle la tension de la polea y ajuste si fuera necesario.
La polea debe moverse 10 –15 mm cuando se presiona con el pulgar (Ver figura 11 pagina 9).
- Controle y ajuste tornillos y tuercas.
- Engrasar los Engrasar los puntos de engrase en el bloque de paletas

HONDA GX-160/GX-240

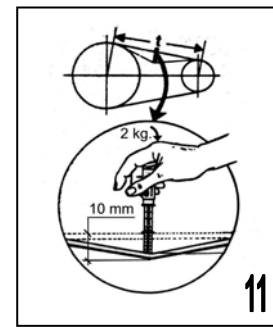
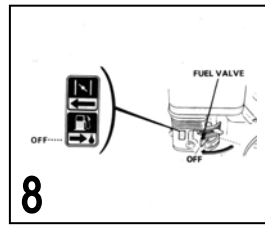
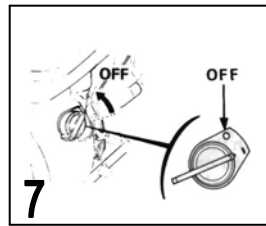
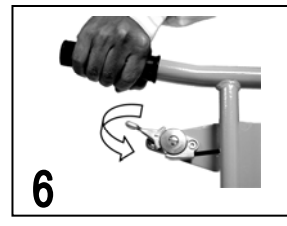
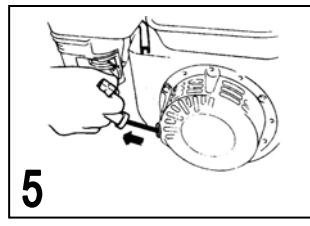
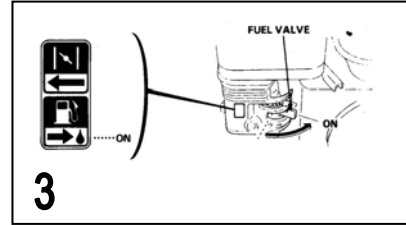
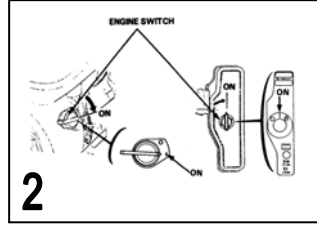



ENGLISH

INSTRUCTIONS FOR ORDERING

Please State Machine Details in the Following Sequence:

- Machine Serial Number
- Part Number, Description and Quantity of Parts
- Full Delivery Address

Manufacturers Liability and the Use of Genuine Spare Parts

Liability for this machine is accepted only when the machine is defective from the outset. Liability is reduced or nullified in the event that the user fails to comply with the operating and maintenance instructions and uses spare parts which are not guaranteed.

DANSK

VEJLEDNING FOR BESTILLING AF DELE

Meddel venligst maskindetaljer på følgende facon:

- Maskinens serienummer
- Reservedelsnummer, beskrivelse og antallet af dele
- Komplet leveringsadresse

Producentens erstatningspligt og brugen af originale reservedele

Vi er kun erstatningspligtige for maskinen, hvis den er defekt fra første færd. Erstatningspligten reduceres eller falder helt bort, såfremt brugeren ikke retter sig efter manualen og vedligeholdelseinstruktionerne og anvender uoriginale reservedele, som ikke er omfattet af garantien.

DEUTSCH

AUFTRAGSBESTELLUNG FÜR ERSATZTEILE

Bitte folgende Details bei Bestellungen definieren :

- Seriennummer der Maschine
- Artikelnummer, Beschreibung und Anzahl der Ersatzteile
- Komplette Lieferungsadresse

Die Ersatzpflicht des Herstellers und die Anwendung von originale Ersatzteile

Die Ersatzpflicht für diese Maschine wird nur akzeptiert, wenn sie von Anfang an defekt ist. Die Ersatzpflicht wird reduziert oder entfällt im Fall der Benutzer sich nicht nach die Manual und die Wartungsinstruktionen richten und Ersatzteile verwendet, die nicht unter der Garantie stehen.

ESPAÑOL

INSTRUCCIONES PARA ORDENAR REPUESTOS

Por favor indicar detalles de la maquina en la siguiente secuencia:

- Numero de Serie de la maquina
- Numero de la parte, Descripcion y cantidad
- Direccion de entrega completa

Responsabilidad de Garantia del Productor y el Uso de Repuestos Genuinos

La Responsabilidad de Garantia por esta maquina sera aceptada solo cuando la maquina contenga defectos de materiales o mano de obra del productor.

La Responsabilidad de Garantia sera reducida o anulada en el caso que el usuario no cumpla con las instrucciones de operacion y mantenimiento o no utilice partes de recambio originales.

Contents

Gear box Spider & Trowels Assy.	Getriebe, Läufer und Glitterteile	Gearkasse og div. tilbehør	Caja reductora y sistema de pacas	11
Guard ring & Engine mounting Assy.	Stellring und Motorersatzteile	Motordetaljer	Ensamblaje del motor y guardas	13
Handle Assy.	Handgriffteile	Håndtag mm.	Manillar	16
Gear box Assy.	Getriebeteile	Gearkassedele	Caja reductora - dstalle	18



GEAR BOX, SPIDER AND TROWELS ASSY.
 GETRIEBE, LÄUFER UND GLITTERTEILE
 GEARKASSE OG DIV. TILBEHØR
 CAJA REDUCTORA Y SISTEMA DE PACAS

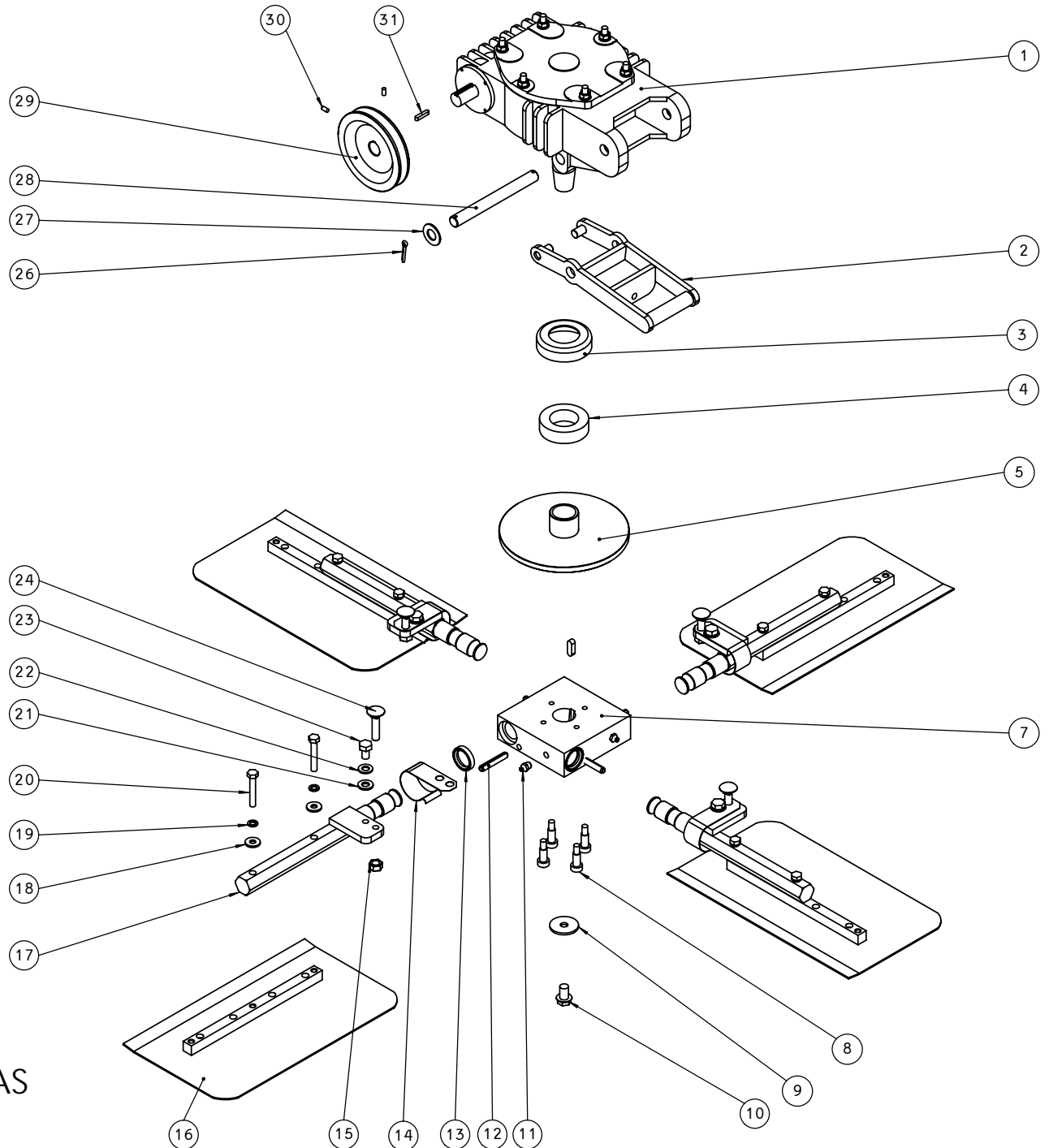

SEE PARTS LIST PAGE 12
 ST92

Caja reductora y sistema de pacas

No.	Part No.	Qty.	Description	Beschreibung	Beskrivelse	Descripción	No.	Part No.	Qty.	Description	Beschreibung	Beskrivelse	Descripción
1	P12130.C	1	Gear box	Getriebe	Gearkasse	Caja de engranajes	21	/	4	Washer	Schraube	Skive	Arandela
2	128167	1	Tilting yoke	Joch	Vælteåg	Horquilla	22	/	4	Spring washer	Federscheibe	Skive	Arandela de seguridad
3	50967	1	Cap-thrust collar	Stellingring	Cap-ring	Anillo protector	23	/	4	Hexagon head screw	Schraube	Skruer	Tornillo hexagonal
4	P50966	1	Thrust bearing	Kugeldrucklager	Aksel	Rodamiento de bolas	24	128921	4	Mushroom head sq.neck Screw	Schraube	Skruer	Tornillos de cabeza abombada y cuello cuadrado
5	128113	1	Pressure plate	Drückplatte	Plade	Cubo levantador de la paleta	25						
6							26	128936	2	Split pin	Splitstift	Splitpind	Pasadores abiertos
7	128117	1	Spider	Läufer	Spider	Arana	27	128938	2	Washer	Schraube	Skive	Arandela
8	128926	4	Hexagon socket head shoulderScrew	Schraube	Skruer	Tornillos de cabeza cilíndrica c/ hueco hexagonal	28	128174	1	Shaft for connecting Gear to Handle and yoke	Achse für verbindung der Getriebe mit der joch	Gearaksel til åg	Eje conector entre casa reductora y horquilla
9	/	1	Washer	Scheibe	Skive	Arandela	29	P51190	1	Driven pulley	Kupplung	Drivrem	Polea
10	128942	1	Self locking hexagon screw	Schraube	Selvlåsende skrue	Tornillos de seguridad hexagonal	30	321943	2	Hexagon socket set screw	Schraube	Skruer	Tornillos sin cabeza c/ hueco hex. y extremo biselado hueco
11	128950	4	Grease nipple	Schmiernippel	Nippel	Grasera	31	128939	1	Key	Nut	Not	Chaveta
12	128922	4	Roll pin	Rollstift	Pind	Maquitos de sujecion-modelo pesado							
13	128927	4	Oil seal	Öldichtung	Oliepakningl	Retentor de aceite							
14	128920	4	Spring	Feder	Fjeder	Resorte							
15	/	4	Hexagon nut	Mutter	Møtrik	Tuerca hexagonal							
16	P12102.H D	4	Combination blade	Kombinationsblatt	Glitterblade	Juego-paletas de combinación							
17	127320	4	Trowel arm	Flügelarm	Glitterarm	Soporte para montane de paletas							
18	/	8	Washer	Scheibe	Skive	Arandela							
19	/	8	Spring washer	Federscheibe	Skive	Arandela de seguridad							
20	/	8	Hexagon head screw	Schraube	Skruer	Tornillo hexagonal							

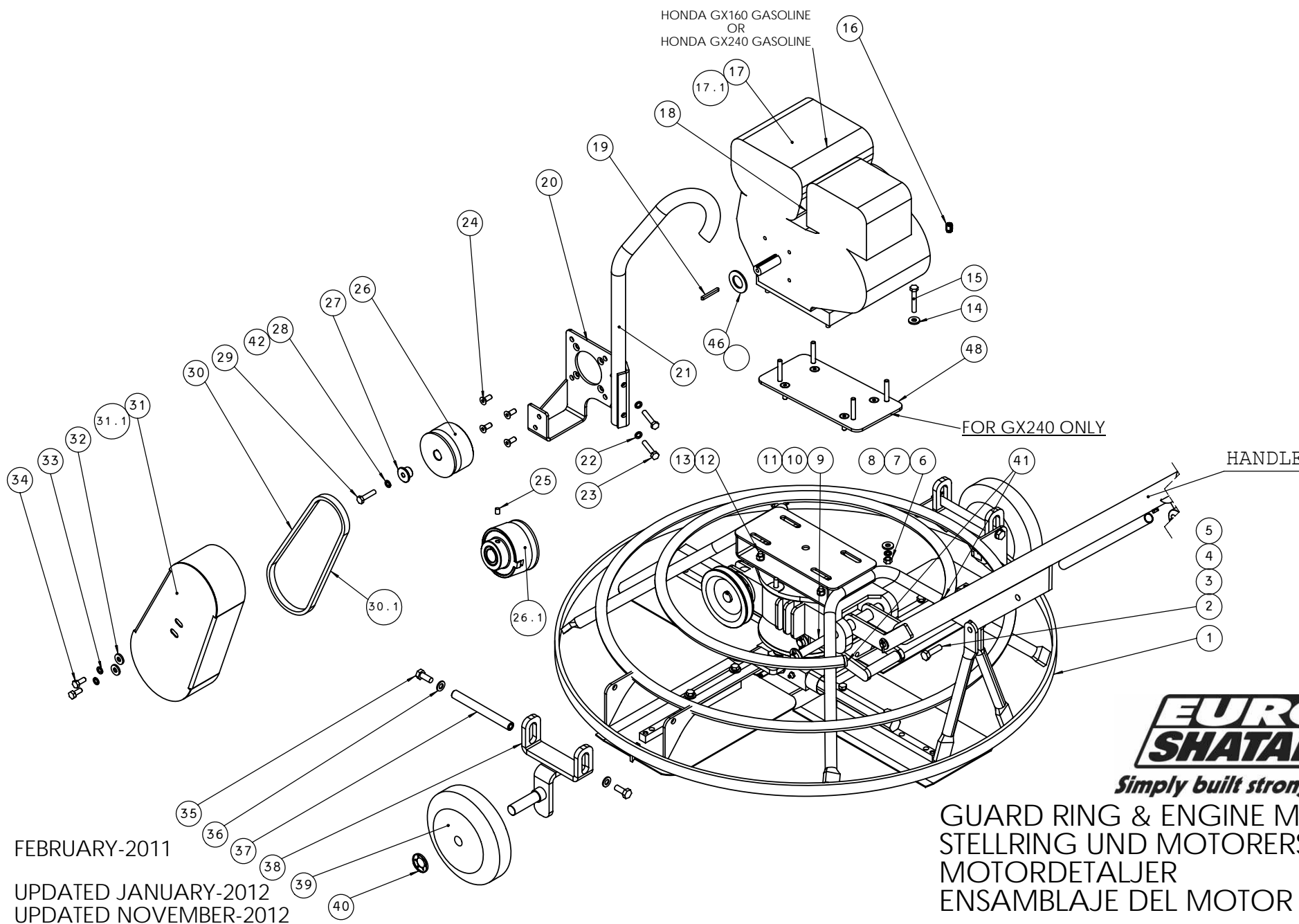

HONDA GX160 GASOLINE
OR
HONDA GX240 GASOLINE

FOR GX240 ONLY

HANDLE



Simply built stronger

GUARD RING & ENGINE MOUNTING ASSY.
STELLRING UND MOTORERSTATZTEILE
MOTORDETALJER
ENSAMBLAJE DEL MOTOR Y GUARDAS

FEBRUARY-2011

UPDATED JANUARY-2012

UPDATED NOVEMBER-2012

UPDATED FEBRUARY-2013

UPDATED JULY 2020

SEE PARTS LIST PAGES 14;15

ST-92

Ensamblaje del motor y guardas

No.	Part No.	Qty.	Description	Beschreibung	Beskrivelse		Descripción	No.	Part No.	Qty.	Description	Beschreibung	Beskrivelse		Descripción
1	127326	1	Guard ring	Stelling	Skærmring		Anillo de protección								
2	/	1	Hexagon head screw	Schraube	Skrue		Tornillo hexagonal	21	128203	1	Lifting hook	Lüftungshaken	Løftekrog		Gancho elevador
3	/	1	Washer	Scheibe	Skive		Arandela	22	/	2	Spring washer	Federscheibe	Skive		Arandela de seguridad
4	/	1	Spring washer	Federscheibe	Skive		Arandela de seguridad	23	/	2	Hexagon head screw	Schraube	Skrue		Tornillo hexagonal
5	/	1	Hexagon nut	Mutter	Møtrik		Tuerca hexagonal	24	129944	4	Hexagon socket countersunk Head Screw	Schraube	Skrue		Tornillos de cabeza avellanada Con hueco hexagonal
6	/	4	Hexagon nut	Mutter	Møtrik		Tuerca hexagonal	25	110538	1	Hexagon socket set screw for clutch P128977.1	Schraube	Skrue		Tornillos sin cabeza con hueco hexagonal
7	/	4	Spring washer	Federscheibe	Skive		Arandela de seguridad	26	P127976	1	Clutch	Kupplung	Kobling		Embrague
8	/	4	Washer	Scheibe	Skive	(Motor hondaGX160)	Arandela	26.1	P128977.1	1	Clutch (Engine honda GX240)	Kupplung (Hondamotor GX240)	Kobling (Honda motor GX240)		Embrague (Motor hondaGX240)
9	128174	1	Shaft for connecting Gear to handle	Achse für Verbindung der Getriebe mit der Handgriff	Gearaksel til håndtag		Eje conector entre casa reductora y manillar	27	127376	1	Clutch retainer	Kupplungshalter	Koblingslås		Tope de embrague
10	128938	2	Washer	Scheibe	Skive		Arandela	28	116900	1	Schnorr locking disc Spring (Engine honda GX160)	Feder (Hondamotor GX160)	Fjeder (Honda motor GX160)		Schnorr arandelas de Seguridad (Motor hondaGX160)
11	128936	2	Split pin	Splitstift	Splitpind		Pasadores abiertos	29	/	1	Hexagon head screw	Schraube	Skrue		Tornillo hexagonal
12	/	4	Hexagon nut	Mutter	Møtrik		Tuerca hexagonal	30	508732	1	Belt for Engine honda GX160	Reimen Hondamotor GX160	Rem Honda motor GX160		Correa Motor hondaGX160
13	/	4	Spring washer	Federscheibe	Skive		Arandela de seguridad	30.1	50831.A	1	Belt for Engine honda GX240	Reimen Hondamotor GX240	Rem Honda motor GX240		Correa Motor hondaGX240
14	/	4	Washer	Scheibe	Skive		Arandela	31	127380	1	Belt guard Engine honda GX160	Reimenschirm Hondamotor GX160	Remskærm Honda motor GX160		Guardacorrea Motor hondaGX160
15	/	4	Hexagon head screw	Schraube	Skrue		Tornillo hexagonal	31.1	127343	1	Belt guard (Engine honda GX240)	Reimenschirm (Hondamotor GX240)	Remskærm (Honda motor GX240)		Guardacorrea (Motor hondaGX240)
16	129969	1	Complete throttle cable clamp	Komplette gaskabelklammer	Gaskabelklamme		Agarradera de cable de velocidad	32	/	2	Washer	Scheibe	Skive		Arandela
17	I50200.M	1	Engine honda GX160	Hondamotor GX160	Honda motor GX160		Motor honda GX160	33	/	2	Spring washer	Federscheibe	Skive		Arandela de seguridad
17.1	I50222	1	Engine honda GX240	Hondamotor GX240	Honda motor GX240		Motor honda GX240	34	/	2	Hexagon head screw	Schraube	Skrue		Tornillo hexagonal
18	209723	1	Safety spring				Resorte de seguridad	35	/	4	Hexagon head screw	Schraube	Skrue		Tornillo hexagonal
19	/	1	Key	Nut	Not		Chaveta	36	/	4	Spring washer	Federscheibe	Skive		Arandela de seguridad
20	128197	1	Lifting hook holder	Lüftungshakenhalter	Løftekrogholder		Agarradera de gancho elevador	37	128155	2	Shaft for wheel assembly	Achse für radmontierung	Hjulmonteringsaksel		Eje rueda sistema de

Ensamblaje del motor y guardas

No.	Part No.	Qty.	Description	Beschreibung	Beskrivelse		Descripción	No.	Part No.	Qty.	Description	Beschreibung	Beskrivelse		Descripción
38	127314	2	Wheel axle	Radachse	Hjulaksel		Eje de rueda	44							
39	51700	2	Wheel	Rad	Hjul		Roue	45							
40	118435	2	Star lock	Verschlussring	Stjernelås		Anillo de retencion	46	127373	1	Inner spacer for clutch P128977.1				
41	320926	2	Pipe plastic plug				Tapon plastico	47							
42	116901	1	Schnorr locking disc Spring (Engine robin EX17)	Feder (Robinmotor EX17)	Fjeder (Robin motor EX17)		Schnorr arandelas de Seguridad (Motor robin EX17)	48	127340	1	Adaptor Plate (Engine honda GX240)	Motorrahmen (Hondamotor GX240)	Motorramme (Honda motor GX240)		Placa adaptadora (Motor hondaGX240)
43															

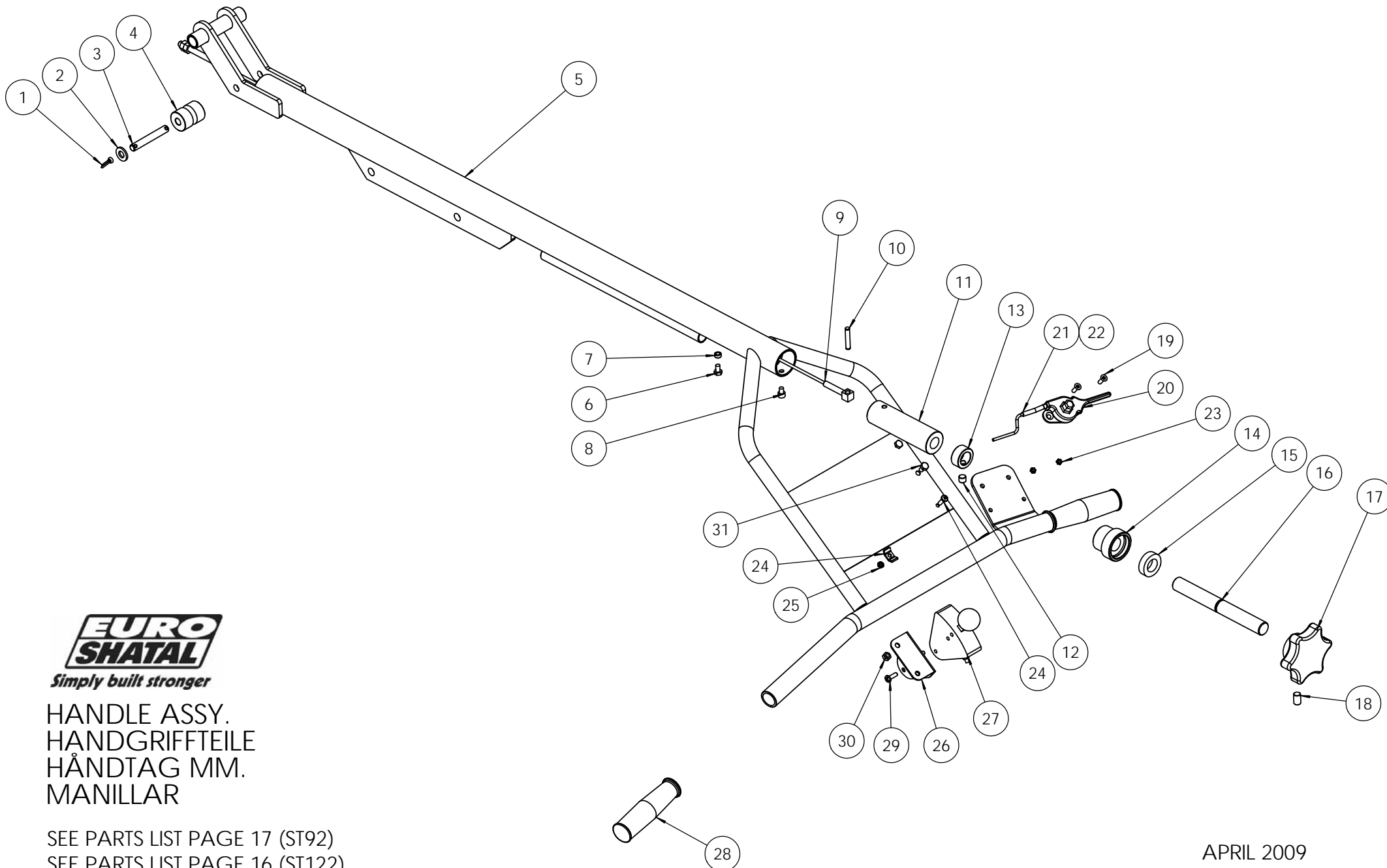

HANDLE ASSY.
HANDGRIFFTEILE
HÅNDTAG MM.
MANILLAR

SEE PARTS LIST PAGE 17 (ST92)
SEE PARTS LIST PAGE 16 (ST122)
ST-92; ST122

-16- (ST92)
-15- (ST122)

APRIL 2009
UPDATED MAR.2021
UPDATED MAR.2023

Manillar

No.	Part No.	Qty.	Description	Beschreibung	Beskrivelse	Descripción	No.	Part No.	Qty.	Description	Beschreibung	Beskrivelse	Descripción
1	128931	2	Split pin	Splitstift	Splitpind	Pasadores abiertos	17	128161	1	Knob	Drehknopf	Drejegreb	Manija
2	/	2	Washer	Scheibe	Skive	Arandela	18	128935	1	Hexagon socket set screw with cup point	Schraube	Skruer	Tornillos sin cabeza c/ hueco hex. y extremo biselado hueco
3	128179	1	Cable pulley shaft	Kabelachse	Aksel til remskivekabel	Eje de polea de cable	19	128928	2	Hexalobular countersunk Head screw	Schraube	Skruer	Tornillos de cabeza avellanda c/ hueco hexagonal
4	128175	1	Cable pulley	Kabelplatte	Remskivekabel	Polea de cable	20	128901	1	Throttle control	Gaskontrolle	Gaskontrol	Control de velocidad
5	1271220	1	Handle (lower end)	Handgriff (unterer teil)	Håndtag (nedre del)	Manillar (extilemo inferior)	21	127930	1	Throttle cable complete for engine GX160 (ST-92)	Komplette gaskabel für GX160 (ST-92) motor	Komplet gaskabel Til motorer type GX160 (ST-92)	Cable de control de velocidad completo p/Motor GX160 (ST-92)
6	/	1	Hexagon socket head cap screw	Schraube	Skruer	Tornillos de cabeza cilindrica c/ hueco hexagonal	22	128930	1	Throttle cable complete for engines EX17;EX27;GX240 (ST-92;122)	Komplette gaskabel für motoren EX17;EX27;GX240 (ST-92;122)	Komplet gaskabel Til motorer type EX17;EX27;GX240 (ST-92;122)	Cable de control de velocidad completo p/Motor EX17;EX27;GX240 (ST-92;122)
7	128166	1	Spacer	Zwischenstück	Mellemstykke	Separador	23	/	2	Hexagon nut	Mutter	Møtrik	Tuerca hexagonal
8	128932	1	Hexagon socket head cap screw	Schraube	Skruer	Tornillos de cabeza cilindrica c/ hueco hexagonal	24	128958	1SET	Set cable holder	Kabelhaltersatz	Kabelholder	Set retentor de cable
9	128181	1	Control cable	Kontrollkabel	Kontrollkabel	Cable de control de palas	25	/	1	Hexagon self locking nut	Mutter	Møtrik	Tuerca auto bloqueante
10	128934	1	Roll pin	Rollstift	Rullepind	Pasadores elastico	26	1271236	1	Switch plate			
11	128165	1	Handle control shaft nut	Handgriffkontrol – Achsemutter	Akselmøtrik	Eje c/rosca de cable control de pacas	27	128965	1	Centrifugal switch			
12	128933	1	Hexagon socket set screw with cup point	Schraube	Skruer	Tornillos sin cabeza c/ hueco hex. y extremo biselado hueco	28	14020	2	Rubber hand grip	Gummihandgriff	Gummihåndtag	Manilla de goma
13	128163	1	Handle bush	Handgriffbusche	Bøsning	Separador manillar	29	/	2	Cross rec.pan head screw			
14	128162	1	Bearing housing	Lagerhaus	Lejehus	Carcaza de rodamiento	30	/	2	Hexagon nut	Mutter	Møtrik	Tuerca hexagonal
15	128906	1	Thrust bearing	Lager	Leje	Rodamiento	31	/	2	Hex head screw	Sechskantschraube	Skruer	Vis à tête Tuerca hexagonal
16	128164	1	Handle control shaft	Handgriffkontrolachse	Håndtagsaksel	Eje de manija de control de pacas							

No.	Part No.	Qty.	Description	Beschreibung	Beskrivelse		Descripción
1	/	12	Hexagon screw	Schraube	Skrue		Tornillo hexagonal
2	1213001	1	Oil seal cover (Open)	Öldichtungsdeckel	Oliepropkappe		Cobertura de junta torica
3	1213014	1	Oil seal	Oldichtung	Olieprop		Retentor de aceite
4	1213002	2	Input shim	Input shim	Input shim		Input shim
5	P50963	3	Ball bearing	Kugellager	Kugleleje		Rodamiento
6	1213003	1	Key	Nut	Not		Chaveta
7	12113	1	Worm gear shaft	Zahnrad	Gearrør		Caja reductora caracol
8	/	1	Gear box housing	Getriebehaus	Gearkassehus		Carcaza de caja reductora
9	P50962	1	Ball bearing	Kugellager	Kugleleje		Rodamiento
10	1213004	1	Oil seal cover (Close)	Öldichtungsdeckel	Oliepropkappe		Cobertura de junta torica
11	1213005	4	Spacer	Zwischenstück	Mellemrør		Espaciador
12	1213006	1	Oil seal cover (Open)	Öldichtungsdeckel	Oliepropkappe		Cobertura de junta torica
13	1213015	1	Oil seal	Oldichtung	Olieprop		Retentor de aceite
14	1213007	1	Output shim - Open	Output shim - Open	Output shim - Open		Output shim - Open
15	1213008	1	Key	Nut	Not		Chaveta
16	128116	1	Vertical shaft	Achse	Aksel		Eje vertical
17	1213009	1	Key	Nut	Not		Chaveta
18	12112	1	Worm wheel	zahnrad	snekkehjul		Rueda caracol
19	1213010	1	Output shim close	Output shim close	Output shim close		Output shim close
20	1213011	1	Circlip	Federring	Fjederring		Anillo de seguridad para eje
21	1213012	1	Gear box cover	Getriebedeckeler	Gearkasseskjold		Tapa de caja reductora
22	/	6	Spring washer	Federscheibe	Skive		Arandela seguridad
23	1213013	6	Stud	Stiftschraube	Tap		Esparragos
24	/	6	Hexagon nut	Mutter	Møtrik		Tuerca hexagonal

